

TekDoc

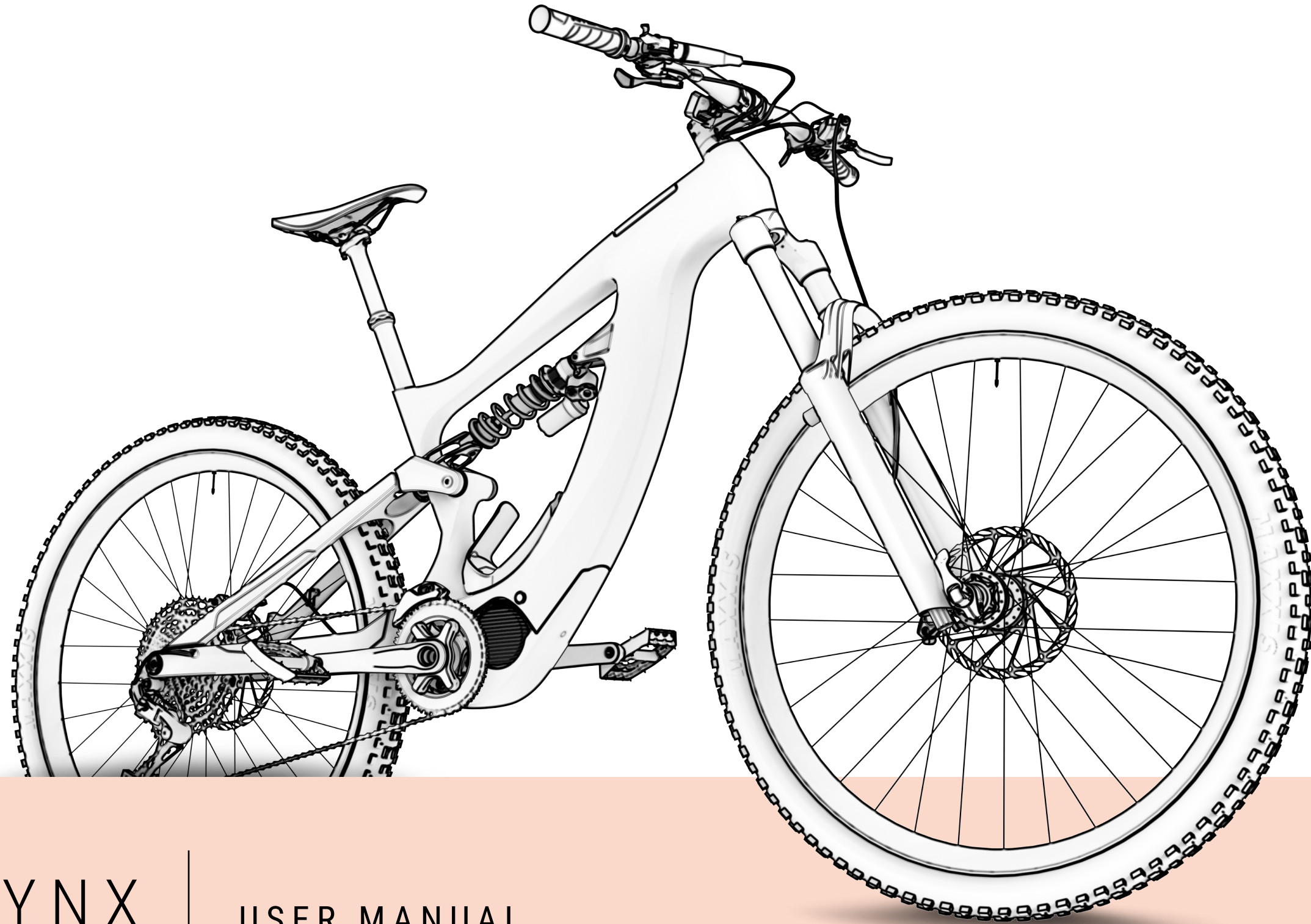

**X**TEP LYNX  
CARBON

USER MANUAL  
2022 MODEL

V0.0

**BH**

# CONTENTS

<b>01 INTRODUCTION</b> .....	<b>3</b>
SYMBOLS .....	3
<b>02 BH WARRANTY</b> .....	<b>4</b>
LIFETIME FRAME WARRANTY.....	4
EXTENDED WARRANTY FOR BH BATTERIES.....	5
REGISTERING EXTENDED WARRANTIES .....	5
WARRANTY OF PARTS OF THE ELECTRICAL ASSISTANCE SYSTEM.....	6
SUBMITTING A WARRANTY CLAIM.....	6
CONDITIONS THAT MAY VOID THE WARRANTY OF ELECTRICAL COMPONENTS.....	6
<b>03 MAINTENANCE</b> .....	<b>6</b>
INSPECT THE BICYCLE BEFORE USE .....	6
KEEP THE BICYCLE CLEAN.....	7
KEEP THE TRANSMISSION LUBRICATED AT ALL TIMES .....	7
PART MAINTENANCE .....	7
SPARE PARTS .....	8
AFTER A FALL, BLOW OR IMPACT.....	8
<b>04 WARNINGS ON USE</b> .....	<b>9</b>
MAXIMUM TYRE SIZE.....	9
MINIMUM AND MAXIMUM INSERTION LENGTH OF THE SEAT POST.....	9
MAXIMUM FORK LENGTH (AXLE-TO-CROWN).....	9
MAXIMUM NUMBER OF STEERING SPACERS .....	9
POSITION OF THE SPINDLE INSIDE THE FORK TUBE .....	9
INTENDED USE .....	9
<b>05 WARNINGS ON USE OF THE ELECTRICAL ASSISTANCE SYSTEM</b> .....	<b>9</b>
CARE AND INSTRUCTIONS FOR USE OF THE ELECTRICAL COMPONENTS AND BATTERIES .....	9
RECOMMENDATIONS TO MAXIMISE THE BATTERY LIFE .....	9
WARNINGS ON THE USE OF BATTERIES .....	9
UNSUITABLE CHARGING AND DISCHARGING ENVIRONMENTS AND SOLUTIONS.....	10
RECYCLING .....	10
MOTOR .....	10
<b>06 PEDAL ASSISTANCE SYSTEM OPERATION</b> .....	<b>10</b>
COMPONENTS OF THE PEDAL ASSISTANCE SYSTEM .....	10
PEDAL ASSISTANCE SYSTEM.....	10
SWITCHING THE PEDAL ASSISTANCE SYSTEM ON AND OFF.....	11
PARTS OF THE CONTROL PANEL.....	11
PARTS OF THE DISPLAY.....	11
SELECTING THE PEDAL ASSISTANCE MODE.....	11
WALK ASSIST MODE.....	12
START OF PEDALLING.....	12
DISPLAYING THE BATTERY CHARGE LEVEL.....	12

BATTERY AND CHARGER.....	13
BATTERY CHARGE LEVEL .....	13
ENERGY SAVING MODES .....	14
SHIMANO ETUBE PROJECT APP .....	15
OPERATION WITH THE GARMIN DEVICE .....	15
ELECTRICAL SYSTEM UPDATES .....	16
ERRORS OF THE PEDAL ASSISTANCE SYSTEM.....	16

<b>07 SIZES AND DIMENSIONS</b> .....	<b>17</b>
--------------------------------------	-----------

<b>08 TECHNICAL SPECIFICATIONS</b> .....	<b>17</b>
--	-----------

<b>09 ASSEMBLY AND SPARE PARTS</b> .....	<b>20</b>
--	-----------

DIMENSIONS OF THE STEERING TUBE.....	20
HEADSET ASSEMBLY.....	20
FIT STEM ASSEMBLY.....	21
MOUNTING THE BH FIT TOOL.....	21
MOUNTING THE BUILT-IN LOCK ON THE SADDLE'S SEAT POST.....	22
REAR AXLE SPLIT PIVOT AND HANGER .....	22
MAIN PIVOT AXLE.....	23
EXPLODED VIEW OF THE ROCKER.....	24
SHOCK ABSORBER ASSEMBLY.....	25
MOTOR COVER .....	25
MOTOR COVER .....	26
BATTERY BRACKET.....	26
PROTECTOR.....	27
BOTTLE HOLDER.....	27
CHAIN GUIDE.....	28
BH-2EXMAG MOTOR CHAINSET .....	28
SPEED SENSOR, CABLE GUIDES AND STAY BOLTS USED TO COUPLE THE BRAKES.....	29
MUDGUARD.....	29
CABLING OF THE MECHANICAL PARTS .....	30
CABLING OF THE ELECTRICAL SYSTEM'S PARTS.....	31
WIRING DIAGRAM OF THE ELECTRICAL SYSTEM'S PARTS.....	32

<b>10 DECLARATION OF CONFORMITY</b> .....	<b>33</b>
---	-----------

<b>11 HELP AND ADDITIONAL RESOURCES</b> .....	<b>33</b>
---	-----------

# 01 INTRODUCTION

This user manual contains important information for proper use and maintenance of the bicycle. In particular, this document contains specific information about the Xtep Lynx Carbon (ES992, ES982, ES972, ES882 y ES872). Please read the entire manual carefully. The user manuals of all BH models can be consulted on the website at the following address:

<https://www.bhbikes.com/manuals>

Keep in mind that the manuals on the BH BIKES website are updated on a regular basis. Make sure you have downloaded the latest version from the website. You can check the version on the front page.

This document contains additional information to the general user manual, available at:

[https://www.bhbikes.com/es\\_INT/quienes-somos/manuales-descargas](https://www.bhbikes.com/es_INT/quienes-somos/manuales-descargas)

You can check the characteristics, recommendations and warranties of third-party parts on their corresponding official websites.

## SYMBOLS

This document contains different icons that refer to use, maintenance and assembly warnings. Carefully read the meaning of each one to prevent improper handling or hazardous situations that may result in serious personal injuries or fatal accidents.

### SAFETY



**DANGER:** refers to a hazardous situation that, if not avoided, will lead to serious injuries or even a fatal accident.



**WARNING:** refers to a hazardous situation that, if not avoided, could lead to serious injuries or even a fatal accident.



**ATTENTION:** refers to a hazardous situation that, if not avoided, could cause minor or moderate injuries.



**RISK OF ELECTRIC SHOCK:** refers to a hazardous situation that, if not avoided, could cause serious injuries due to electric shock or even death.



**RISK OF SHORT CIRCUIT:** refers to a hazardous situation that, if not avoided, could cause short circuits in the electrical components. Short circuits may cause damage to the electrical components and fire.

### TOOLS



**FLAT WRENCH**



**ALLEN KEY**



**TORX KEY**



**PHILLIPS SCREWDRIVER**



10Nm

**TIGHTENING TORQUES:** on one side of each tool symbol, the tightening torque will be indicated in newton metre.

### TYPE OF ASSEMBLY COMPOUND



**OIL:** light lubrication for elements such as chains and cables.



**GREASE:** assembly grease.



**CARBON PASTE:** assembly paste used to increase the friction of the carbon elements.



**ADHESIVE:** use medium strength thread lock.



Adhesive is used to fasten bolts and make sure that they do not come loose due to vibrations when using the bicycle. Add a drop of thread lock to the tip of the screw thread in all cases. Never apply more than one drop around the thread, since this will make it very hard to remove the bolt.

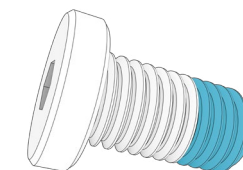

## 02 BH WARRANTY

BH BIKES undertakes to offer long-lasting bicycles, in compliance with the highest standards of quality. Therefore, in addition to the statutory warranty, BH BIKES offers an additional coverage and warranty. This section defines the different types of warranty and the process that must be followed to register for the additional "LifeTime Frame" warranty.

### STATUTORY WARRANTY

The statutory warranty covers the original purchaser in the event of manufacturing defects and/or non-conformities. This warranty applies to frames and components manufactured by BH BIKES. The warranty period will be established according to the current laws of the country where the bicycle was purchased, and will start on the date of purchase. During this period, the holder of the warranty will be entitled to have all manufacturing defects repaired or replaced free of charge, including the reimbursement of transport expenses and any losses caused as a result of this. Different conditions must be met in order to be covered by the warranty:

- This warranty does not affect the consumer's applicable rights, according to the current laws in each country.
- Faulty bicycles or parts will be covered by warranty upon the decision of our Technical Service.
- The warranty does not include the replacement of parts prone to wear and arising from normal use of the bicycle.
- The warranty does not cover defects or broken parts due to improper use of the bicycle, use for competitions, mounting of non-original accessories or improper handling and incorrect maintenance work.
- The warranty does not apply if the inspection before delivery and the corresponding inspection intervals included in this document have not been carried out, observed, documented as required and stamped by an authorised BH dealer.
- Should the repair not be satisfactory and not ensure that the optimum conditions are met according to the intended use, the holder of the warranty will be entitled to request the replacement of the purchased item or faulty part with one of identical characteristics, or to receive a refund of the amount paid for the damaged item or part.
- The warranty period will be interrupted during the repairs or, in the event of replaced items or components, it will be renewed.
- Any claim against this warranty shall expire six months after the end of the warranty validity period.
- All warranty claims must be processed by an authorised dealer.
- Geographical scope: refer to the User Manual or [www. BHbikes.com](http://www.BHbikes.com)

Visit the following link to read the terms and conditions:

[https://www.bhbikes.com/es\\_INT/registro-garantia-vida-bh/registra-tu-bici-garantia-de-por-vida](https://www.bhbikes.com/es_INT/registro-garantia-vida-bh/registra-tu-bici-garantia-de-por-vida)

## LIFETIME FRAME WARRANTY

Through its authorised stores, BH Bikes provides the original buyer with a commercial policy to cover any manufacturing defects in frames for a period beyond that specified in the product's statutory warranty, pursuant to the following clauses:

1. **The LIFETIME warranty solely applies to BH frames and bikes that are sold through stores that are authorised by BHBIKES EUROPE S.L.**
  - The buyer must register the LIFETIME warranty online, with the information duly completed, within 30 calendar days of the purchase date, as it appears on the invoice issued by the authorised store.
  - This warranty cannot be transferred to subsequent buyers and it is cancelled when the bicycle is sold to a third party. Original buyer means the individual who registers the warranty at the time of the purchase; the commercial warranty cannot be transferred to third parties who are not the original buyer.
  - It shall be compulsory to have the bicycle serviced in an establishment that is authorised by BHBIKES EUROPE and according to the instructions in the user manual.
2. **The LIFETIME warranty does not cover:**
  - The rear swingarms of the double suspension models, fork, kids' bikes, defects and/or fading of the original paint, or rust caused by natural deterioration.
  - Defects or breakages resulting from an accident or improper and/or negligent use of the bicycle.
  - When components or accessories that are not intended for or are not compatible with the use for which the bicycle was designed have been installed.
  - Defects resulting from improper handling.
  - Scratches, discolouration, or stains caused by the use of abrasive fluids, sharp items, clamps and/or prolonged exposure to sunlight or other weather conditions.
  - Defects caused by the bicycle's normal wear and tear, including those due to material fatigue. Fatigue damage is a sign that the frame has been damaged by normal use, so it is the user's responsibility to regularly inspect the bicycle.
  - Improper use and/or maintenance of the product (carefully read the recommendations for use and cleaning).
  - Frames that have been used in competitions, demos or as rentals.

Read the full terms and conditions at:

[https://www.bhbikes.com/es\\_INT/registro-garantia-vida-bh/registra-tu-bici-garantia-de-por-vida](https://www.bhbikes.com/es_INT/registro-garantia-vida-bh/registra-tu-bici-garantia-de-por-vida)

## EXTENDED WARRANTY FOR BH BATTERIES

In a constant effort to improve our customer services on a daily basis, BH offers the best warranty conditions and the possibility of acquiring an extended warranty for its e-Bike range (an additional one or two years). Through its authorised stores, BH Bikes provides the original buyer with a commercial policy to cover any manufacturing defects in BH batteries for a period beyond that specified in the product's statutory warranty, pursuant to the following clauses:

- The BH battery extended warranty solely applies to BH batteries installed in BH bikes and sold through stores that are authorised by BHBIKES EUROPE S.L.:**
  - The buyer must register the warranty online, with the information duly completed, within 30 calendar days of the purchase date, as it appears on the invoice issued by the authorised store, on which the bike's serial no. must be specified.
  - This warranty cannot be transferred to subsequent buyers and it is cancelled when the bicycle is sold to a third party. Original buyer means the individual who registers the warranty at the time of the purchase; the commercial warranty cannot be transferred to third parties who are not the original buyer.
  - It shall be compulsory to have the bicycle serviced in an establishment that is authorised by BHBIKES and according to the instructions in the user manual.
- The BH battery extended warranty shall not ever cover:**
  - Fading paintwork and a loss of original colour, or corrosion caused by normal wear and tear.
  - Defects or breakages resulting from an accident or improper and/or negligent use of the bicycle.
  - Deterioration or natural degradation due to age, even without use. Deterioration after 500 full charging and discharging cycles if it is below 30% of the nominal capacity (read the recommendations in the user manual carefully).
  - When components or accessories have been installed that are not intended for/compatible with the use for which the bicycle was designed.
  - Defects resulting from improper handling.
  - Scratches, discolouration, or stains caused by the use of abrasive fluids, sharp items, clamps and/or prolonged exposure to sunlight or other weather conditions.
  - Improper use and/or maintenance of the product (carefully read the recommendations for use and cleaning).
  - Batteries that have been used in competitions, demos or in rentals.
  - Auxiliary batteries (extenders).

Read the full terms and conditions at:

[https://www.bhbikes.com/es\\_INT/registro-garantia-vida-bh/extension-garantia-bateria](https://www.bhbikes.com/es_INT/registro-garantia-vida-bh/extension-garantia-bateria)

## REGISTERING EXTENDED WARRANTIES

You must register the bicycle within 30 days after purchase to enjoy the BH BIKES additional warranties. The process to activate the extended warranties is described below:

### • LIFETIME FRAME WARRANTY

You must register the bicycle on the BH BIKES website to enjoy the LIFETIME FRAME extended warranty:

[https://www.bhbikes.com/es\\_INT/registro-garantia-vida-bh/registra-tu-bici-garantia-de-por-vida](https://www.bhbikes.com/es_INT/registro-garantia-vida-bh/registra-tu-bici-garantia-de-por-vida)

Watch this video to find out what you need to do:

<https://youtu.be/47aLVgUI248>



### • EXTENDED WARRANTY FOR BH BATTERIES

You must register the bicycle on the BH BIKES website to enjoy the BH BATTERY extended warranty:

[https://www.bhbikes.com/es\\_INT/registro-garantia-vida-bh/extension-garantia-bateria](https://www.bhbikes.com/es_INT/registro-garantia-vida-bh/extension-garantia-bateria)

Watch this video to find out what you need to do:

<https://youtu.be/sINzdFBygMM>



- ⚠ The serial number required to register the bicycle is located on the bottom of the bicycle, under the bottom bracket:

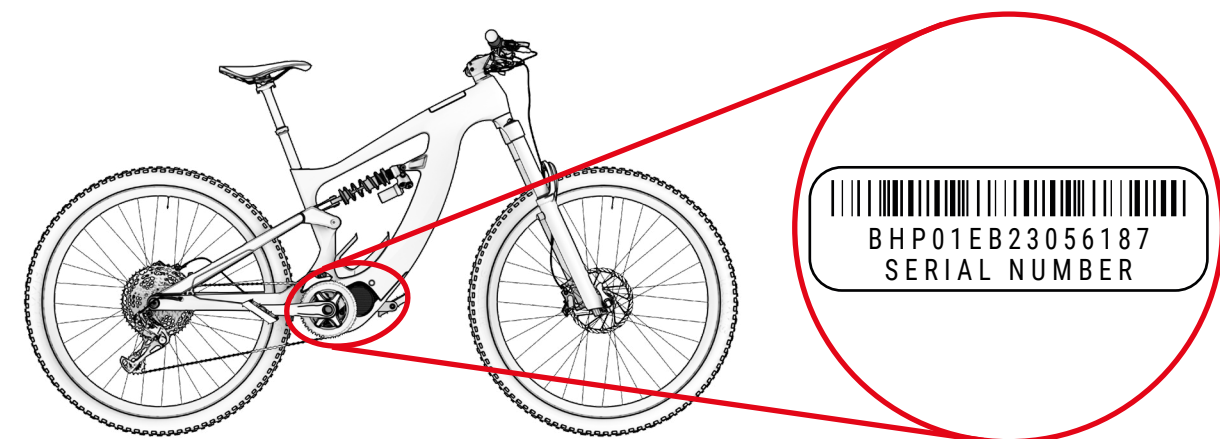

## WARRANTY OF PARTS OF THE ELECTRICAL ASSISTANCE SYSTEM

As in the case of BH BIKES frames and parts, all electrical components made exclusively for BH will be covered by the statutory warranty (BH motors feature an extended 5-year warranty after the LIFETIME FRAME warranty is activated). The warranty period will be established according to the current laws of the country where the bicycle was purchased, and will start on the date of purchase.

During this period, the holder of the warranty will be entitled to have all manufacturing defects repaired free of charge, including the reimbursement of transport expenses and any losses caused as a result of this. The terms and conditions are as described in the section "Statutory Warranty" and can be read at:

<https://www.bhbikes.com/manuals>

Under no circumstances shall the warranty cover the wear and natural ageing of batteries due to use, charging and storage. Likewise, the buyer must contact the original manufacturer to use the warranty of third-party parts.

## SUBMITTING A WARRANTY CLAIM

All warranty claims must be channelled through an official BH dealer. The dealer will analyse the claim to identify its scope and perform a preliminary assessment of the incident. The dealer will submit and process the claim directly with BH. Once BH has defined the corrective measures required, the dealer will send this information to the customer.

All claims must be processed by the official dealer from which you purchased your bicycle. If this is not possible, please contact us directly. We will help you find an authorised dealer near you:

[https://www.bhbikes.com/es\\_INT/quienes-somos/contacto](https://www.bhbikes.com/es_INT/quienes-somos/contacto)

## CONDITIONS THAT MAY VOID THE WARRANTY OF ELECTRICAL COMPONENTS

The BH battery and electrical components are covered by the statutory warranty, but the following requirements must be met:

- No electrical components must be removed or tampered with.
- The service life will vary according to the use, charging and storage conditions.
- Keep the battery charged at all times. Otherwise, the battery may deteriorate faster than normal.

## 03 MAINTENANCE

This user manual contains important information for **Xtep Lynx Carbon (ES992, ES982, ES972, ES882 y ES872)**. Please read the entire manual carefully. The user manuals of all BH models can be consulted on the website at the following address:

<https://www.bhbikes.com/manuals>

This document contains additional information to the general user manual, available at:

<https://www.bhbikes.com/manuals>

You can check the characteristics and recommendations of third-party parts on their corresponding official websites.

## INSPECT THE BICYCLE BEFORE USE

Bicycles are inspected several times throughout the manufacturing process and then at the BH workshop during the final check. As the bicycle's operation may be affected during transport or third parties may have modified the bicycle before its sale, the following must be checked before each trip:

- **FRAME:** no cracks, damage or strange noises.
- **CHAIN:** it must be lubricated and the transmission system must not make any strange noises.
- **BRAKES:** the brakes must be working properly. When stopped, press the brake lever with enough strength and check that it does not touch the handlebars.
- **TYRES:** the pressure must be correct and there must be no cuts on the tread or on the sides. Also check that the wear level does not exceed the maximum recommended level.
- **WHEELS:** the wheels must rotate freely in order to check how they rotate. Also check the space between the brake lining and the rim, as well as the space between the frame and tyre.
- **STEERING:** the steering must turn smoothly and with no strange noises.
- **SWINGARM ROTATION POINTS:** when weight is exerted on the bicycle, the suspension must work as expected and with no strange noises. If it is not working properly or there is play between the moving parts, this might mean that the tightening torques are incorrect or that the bearings are worn.
- **BEARINGS:** the bearings must work properly and with no strange noises. The bearings are subject to wear and must be replaced to prevent damage to the components on which they are installed.
- **ELECTRICAL SYSTEM:** if the bicycle features an electrical system, check that it is functioning properly by ensuring that the electrical assistance mode is running and that all parts are functioning properly (motor, display, change of assistance mode and speed sensor). If there is no electrical assistance, check that all connections are correct and show no signs of damage.

⚠ Do not ride your bicycle if it does not meet any of these points! A faulty bicycle may cause serious accidents! If you are unsure or have any queries, please contact your nearest BH workshop!

⚠ Check the tightening torques to make sure that they are as described in the recommendations in the user manuals. Failure to observe these recommendations may result in accidents and even death.

⚠ The effect of the ground and the forces exerted on the wheel subject the bicycle to a lot of stress. The different parts will be subject to fatigue and wear because of these dynamic loads. Check the bicycle at regular intervals to look for signs of wear, scratches, bent parts, wear on the finish or the formation of cracks. Parts may fail suddenly after their service life has expired. Take your bicycle to an authorised BH workshop regularly to have these parts replaced if needed.

## KEEP THE BICYCLE CLEAN

We recommend you follow these basic prevention measures to make sure that the bicycle is in perfect working order. Failure to observe these recommendations may lead to premature wear or even breakages in specific areas, such as gaskets or moving parts.

- Clean the dust and mud with a damp sponge and a gentle and neutral cleaning product.
- Plastic parts must only be washed with soapy water.
- Tyres can be washed with a sponge or brush and soapy water.
- After cleaning the bicycle, dry it by rubbing it firmly with a smooth cloth.
- After each cleaning, lubricate the transmission elements.

⚠ Dirt may cause damage that can result in accidents or even death.

⚠ Never use pressure washers or steam cleaners.

## KEEP THE TRANSMISSION LUBRICATED AT ALL TIMES

After washing the bicycle, the chain transmission's lubrication may have also been washed off. Inspect and lubricate the chain's links, if needed. Excess lubrication may attract more dirt, causing premature wear and incorrect functioning of the system.

⚠ Never use pressure washers or steam cleaners.

## PART MAINTENANCE

The bicycle requires regular maintenance and a minimum number of regular inspections. The frequency of the maintenance operations depends on the type of vehicle (leisure, road or mountain bike), as well as the frequency and conditions of use.

## PART MAINTENANCE CALENDAR

Part	Action required	Before each outing	Monthly	Annually
Lighting	Functional check.			
Tyres	Pressure check.			
	Inspect the height of the profile and sides.			
Brakes (on the rim)	Check the lever travel, lining strength and rim position.			
	Brake test when stopped.			
	Clean the brake pads.			
Brake cables	Visual inspection.			
Brakes (disc brakes)	Change the brake fluid (DOT fluid).			
Suspension fork	Check the bolts and the corresponding tightening torque.			
	Change the oil and lubricate the elastomer.			
Saddle seat post with suspension	Maintenance.			
	Play check.			
Rims on rim brakes	Inspection and replacement, if needed, of the wall linings.	At the latest after the second part of the brake lining.		
Bottom bracket axle	Check the play.			
	Re-lubrication.			
Chain	Check and lubrication.			
	Check and replacement.	After 800 km.		
Chainsets	Check and tightening.			
Wheels / Spokes	Check wheel spin and spoke tension.			
Headset	Inspection of the headset.			
	Re-lubrication.			
Metal surfaces	Maintenance.	At least once every six months.		
Hubs	Bearing inspection.			
	Re-lubrication.			
Pedals	Bearing inspection.			
	Lubrication, cleaning the anchoring mechanism.			

Part	Action required	Before each outing	Monthly	Annually
Saddle seat post / Stem	Inspection of the fastening screws.			
Rear derailleur / Derailleur	Cleaning, lubrication.			
Quick-release mechanism / Thru-axle	Efficacy check.			
Nuts and bolts	Check and tightening.			
Spokes	Tension check.			
Stem / Saddle seat post	Removing and applying new assembly paste.			
Circuit / Brakes	Disassembly and greasing.			
Components of the electrical assistance system	Check the connections.			
	Check there is no dirt.			

 You do not need to take the bicycle to an expert if you are skilled, experienced and have the appropriate tools. Immediately implement the corrective measures if you detect problems. If you are unsure or have queries, please contact BH.

 The tasks described above must only be carried out by a trusted bike repair expert.

## SPARE PARTS

Original parts must be used to ensure the optimum performance of your bicycle and the utmost safety. Failure to use original parts may cause damage that is not covered by the warranty.

The most common spare parts are parts prone to wear. The most common ones are tyres, inner tubes, brake pads, disc brakes and brake pads, as well as rims, when these are part of the brake unit, headlights, position lights, batteries and accumulators.

- **TYRES:** Replace them with an equivalent type of tyre. Check the marking on the outside of the tyre (ETRTO standard). Keep in mind that using a tyre with a larger outer diameter than the recommended one may cause the tip of the foot to touch the front wheel or rear wheel guard when the handlebars turn. The cyclist may lose control of the bicycle and suffer an accident with serious consequences. This can also occur when the pedal chainset is replaced with a longer one.
- **INNER TUBES:** Replace them with a suitable type of inner tube, according to the type of tyre. Refer to the information on the outside of the inner tube (ETRTO standard).
- **DISC BRAKES AND BRAKE PADS:** Follow the instructions supplied by the manufacturer.
- **HEADLIGHTS AND POSITION LIGHTS:** Replace the bulb with one of the same type. Check the indication on the metal area.

- **CHAIN, COG AND CHAIN RINGS:** Follow the instructions supplied by the manufacturer.
- **BATTERIES AND ACCUMULATORS:** Change for the same type. Check the indication on the outer area.

 Remember that the failure to use original parts may cause damage that is not covered by the warranty.

## AFTER A FALL, BLOW OR IMPACT

If you suffer a fall, blow or impact, first make sure that you are okay to continue cycling. Do not use the bike if you are injured and ask for medical assistance if needed.

If you are okay to continue cycling, check the bicycle to make sure that it is in perfect working order:

- Check that the wheels are firmly secured and that the rims are in the centre of the frame and fork. Turn the wheels. If they cannot be centred in situ because the gap is too small, separate the brakes from the rim so it can move freely.

 In this case, keep in mind that the braking efficacy will be less.

- Check whether the handlebars or the front of the frame are twisted or broken. Check that the front is firmly seated on the fork, holding the front wheel firmly between your legs and trying to twist the handlebars with respect to the front wheel.
- Check that the chain is fitted correctly. If the bicycle fell onto the transmission side, check that it is working properly. Ask for help to place the bicycle on its saddle and change gears. When the chain fits on the largest cog, check the distance between the gear and the spokes. If the gear or bracket are bent, the first one may become stuck on the spokes - Danger of falling! The gear, rear wheel or frame may be damaged. Check the derailleur. If it has shifted, the chain may come off the gear. The bicycle's transmission will become less effective (also refer to the "Traction" section).
- Check the saddle, upper tube or the bottom bracket box to make sure that there are no defects.
- Lift the bicycle slightly and let it drop onto the ground. If there are any noises, inspect the bicycle for any loose bolts.
- Inspect the entire bicycle again to check for bent areas, worn finish or cracks.
- Ride again carefully if no problems have been detected during the inspection. Do not brake or accelerate suddenly or pedal when going uphill. If you are unsure, wait for a car to pick you up instead of risking an accident. Once home, you should inspect the bicycle carefully again. If you are still unsure or have any queries, please contact your nearest BH workshop!

 Bent aluminium parts must not be straightened, i.e., they must not be repaired. Even afterwards, there is a high risk of breakage, especially in regards to the fork, handlebars, front part, chainsets and pedals. Replace them for greater safety.



## **04** WARNINGS ON USE

### **MAXIMUM TYRE SIZE**

If you install a tyre of a different size on your bicycle, check and make sure that there are at least 6 mm between the tyre and other parts of the frame and fork.

### **MINIMUM AND MAXIMUM INSERTION LENGTH OF THE SEAT POST**

Failure to observe the maximum and minimum seat post insertion dimensions indicated in this manual may cause a lever effect on the frame. The pressure exerted could damage the frame and cause serious accidents. The warranty does not cover the damage generated by failing to observe these indications.

### **MAXIMUM FORK LENGTH (AXLE-TO-CROWN)**

Observe the maximum length between the fork axle and the lower part of the steering tube (axle-to-crown). If this maximum length is not observed, the frame could be damaged due to withstanding a greater load than that for which it was designed and may cause serious accidents.

### **MAXIMUM NUMBER OF STEERING SPACERS**

This manual specifies the maximum number of steering spacers that can be fitted under the stem. If this maximum quantity is not observed, the materials could be damaged due to withstanding a greater load than that for which they were designed and may cause serious accidents.

### **POSITION OF THE SPINDLE INSIDE THE FORK TUBE**

No steering spacers must be fitted above the stem. Otherwise, the materials could be damaged due to withstanding a greater load than that for which they were designed and may cause serious accidents.

### **INTENDED USE**

Each bicycle has been designed according to a specific intended use. The models described in this manual meet the requirements associated with their intended use:

These refer to the conditions that guarantee the proper functioning of the bicycle, such as riding on difficult trails, unpaved paths and difficult terrain and trails that require technical skills. The maximum jumping and/or drop height is 61 cm (24").

## **05** WARNINGS ON USE OF THE ELECTRICAL ASSISTANCE SYSTEM

### **CARE AND INSTRUCTIONS FOR USE OF THE ELECTRICAL COMPONENTS AND BATTERIES**

All BH products and parts have been designed to withstand splashed liquids and rain. However, some practices may cause damage to the parts and short circuits. Do not do the following:

- Wash the bicycle with pressure devices.
- Use the bicycle under adverse weather conditions.
- Transport the bicycle on the outside of a vehicle when it is raining.
- Expose the batteries to very high temperatures. If the temperature exceeds 70°C, this could cause leaks and there could be a risk of fire.
- Fail to observe the working temperature, storage and charging range of the bicycle.

### **RECOMMENDATIONS TO MAXIMISE THE BATTERY LIFE**

We recommend the following to maximise the battery life:

- Charge it on a flat and stable surface.
- Make sure that it is not exposed to direct sunlight.
- Make sure that there are no children or pets near.
- Make sure that there is no rain or dampness.
- The place must be well ventilated and dry.
- The temperature must be between 15-25°C.
- Do not use the battery with a charge of less than 10%. The useful life of the cells may be affected below this charge level.

 Any unauthorised handling of the electrical system's components may cause serious accidents and will void the warranty.

### **WARNINGS ON THE USE OF BATTERIES**

Improper use of the batteries may cause damage and serious accidents. Follow these recommendations to prevent this:

- Always use the original battery charger.
- Never leave the battery near sources of heat.
- Do not heat the battery or throw it into a fire.

- Prevent the battery connections from coming into contact with metal objects.
- Do not submerge the battery in water and prevent splashes and dampness.
- Do not hit or drill holes into the battery.
- Make sure that the battery liquid does not touch your hands or eyes in the event of a leak.
- Do not use it if there are external signs of damage.
- Only clean the battery with a dry or damp cloth.

## UNSUITABLE CHARGING AND DISCHARGING ENVIRONMENTS AND SOLUTIONS

The hot and cold environments described below may lead to charging entering standby or sleep mode without fully charging the battery.

- **Winter discharging sleep mode or DUT (Discharge Under Temperature):** Battery discharging will enter the deep sleep mode if the temperature is below  $-20^{\circ}\text{C}$ , stopping the pedal assistance system from working and protecting the battery. In such cases, sleep mode will automatically be disabled when the battery exceeds  $-20^{\circ}\text{C}$ .
- **Winter charging sleep mode or CUT (Charge Under Temperature):** Battery charging will enter sleep mode if the temperature is below  $0^{\circ}\text{C}$ . If charging starts and the temperature falls below this level due to night cooling or other factors, charging will stop and sleep mode will be activated to protect the battery. In such cases, sleep mode will automatically be disabled when the battery exceeds  $0^{\circ}\text{C}$ .
- **Noise on televisions/radios/computers:** Charging near televisions, radios or similar devices may cause static electricity, flickering images and other interference. If this happens, recharge somewhere that is away from the television or radio (e.g. in another room).

## RECYCLING

Ion-lithium batteries can be recycled but they may harm the environment if they are not managed properly after the end of their service life. Follow these steps after the end of their service life:

- Classify and recycle each electrical component in a place prepared for the sustainable recycling of such parts.
- Check and make sure that the applicable regulations of your country are observed with regards to batteries.

## MOTOR

The DC motor is located on the bottom bracket bearing axle. As with any other part of your bicycle, the service life of the motor depends on how it is used. Under normal conditions, the motor can last for 10 to 20 years, or up to 100,000 km.

In the case of ATOMX models with a central motor, it is compulsory for the motor unit to be inspected by a Brose-certified service centre after 15,000 km.

# 06 PEDAL ASSISTANCE SYSTEM OPERATION

## COMPONENTS OF THE PEDAL ASSISTANCE SYSTEM

The BH Bikes pedal assistance system is made up of the following components:

- **A. A motor**, which drives the bicycle.
- **B. A control panel** (EM800), which, among other things, allows you to select the assistance mode.
- **C. A battery**, which powers the motor and can be located in different places.
- **D. A torque sensor**, which reads the force applied to the pedal by the user.
- **E. A display** (EM800), which shows relevant system information.

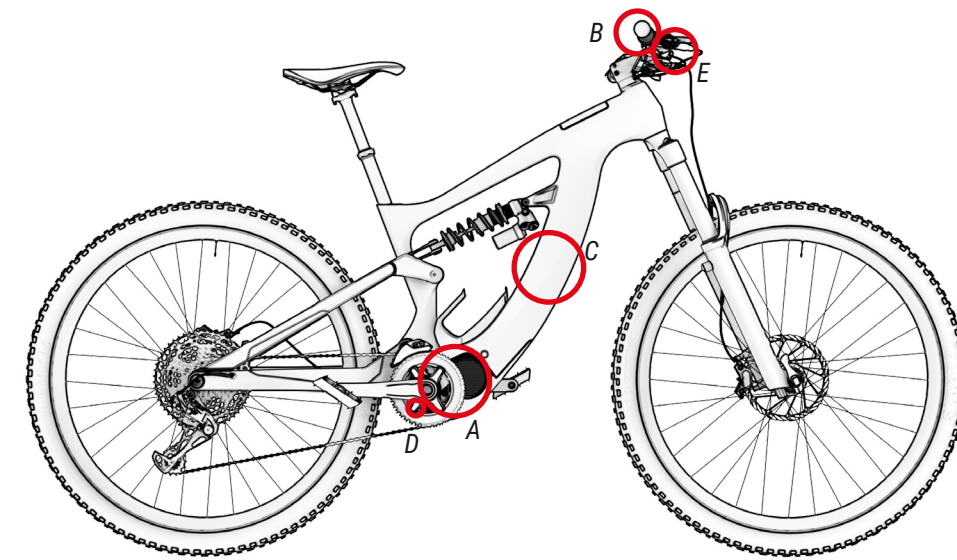

## PEDAL ASSISTANCE SYSTEM

The pedal assistance system is designed to provide the optimal amount of assisted power. It provides assistance within a standard range, based on factors such as the pedalling force, the speed of the bicycle and the transmission.

The system does not provide assistance in the following situations:

- If the control panel is off.
- When travelling at 25 km/h or faster.
- If you are not pedalling and the throttle function is released at 6 km/h.
- If there is no remaining battery capacity.
- If the assistance mode selected is 0% assistance.

## SWITCHING THE PEDAL ASSISTANCE SYSTEM ON AND OFF

The pedal assistance system is activated from the power button on the cover that releases the battery, on the top of the frame (see the image below). Press the power button to start the system. The display will start, showing the home screen. If the battery has been removed from the frame and put back into its position, the system will also turn on, first showing the same blue LED (see the section "Releasing and removing the battery").

To turn off the pedal assistance system, press and hold the power button for 3 seconds. The display will turn off and the system will shut down.

- ⚠ After turning the system on, make sure that you do not start riding without checking the assistance mode. By default, it starts with the assistance mode selected before it was last switched off.
- ⚠ Wait for 3 seconds after turning on the system before you start applying pressure on the pedals. During this 3-second period, the assistance system is starting up and calibrating the torque sensor. Otherwise, if you press the pedals beforehand, this may reduce the effectiveness of the assistance system and error 14 may even be displayed on the screen (see the "Error code" section). To fix this, you should reboot the system without applying pressure to the pedals for the 3-second period.

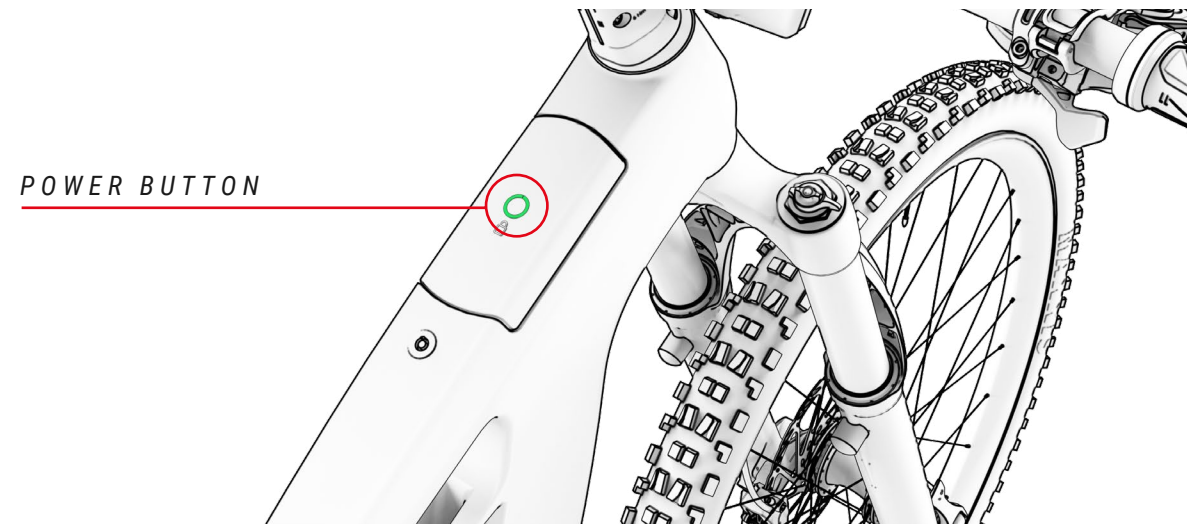

## PARTS OF THE CONTROL PANEL

The EM800 general control panel is located on the left side of the handlebars, next to the grip. The control consists of 2 parts:

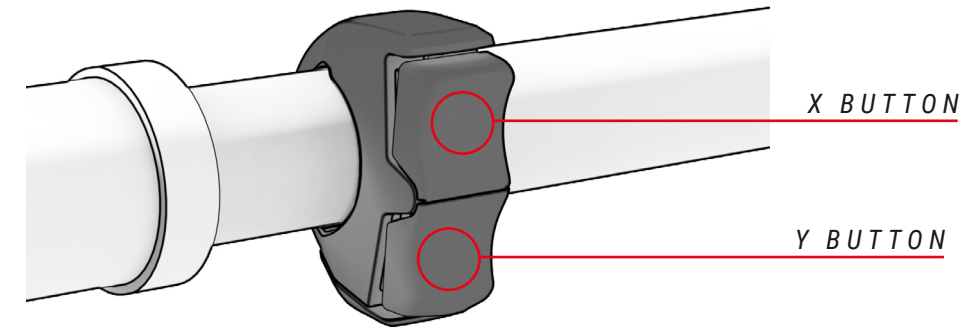

## PARTS OF THE DISPLAY

The SC-EM800 display is located on the handlebars, to the right of the stem. It features a button on the bottom part, which can be used to toggle the different screens that show specific information, such as the activity time, maximum and minimum speed, etc.:

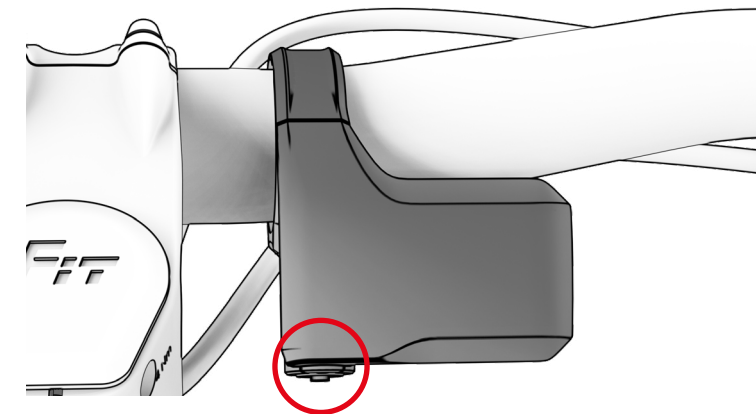

## SELECTING THE PEDAL ASSISTANCE MODE

The system has different pedal assistance modes:

- **Boost:** Use when you want to get peak power from the system.
- **Track:** Use when you want to obtain gradual power, according to the user's torque
- **Eco:** Use when you want to travel as far as possible.
- **No assist:** Use when you want to travel without assisted power. You can continue to use the other functions of the control panel.

To scroll through the assistance modes, the user must press the (X) button to increase the level of assistance and the (Y) button to reduce the level of assistance. The bottom left of the display shows the current mode selected for the bicycle.

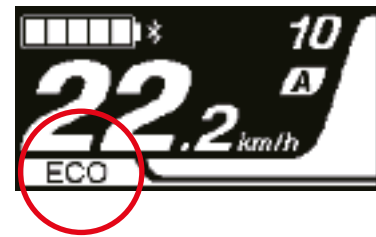
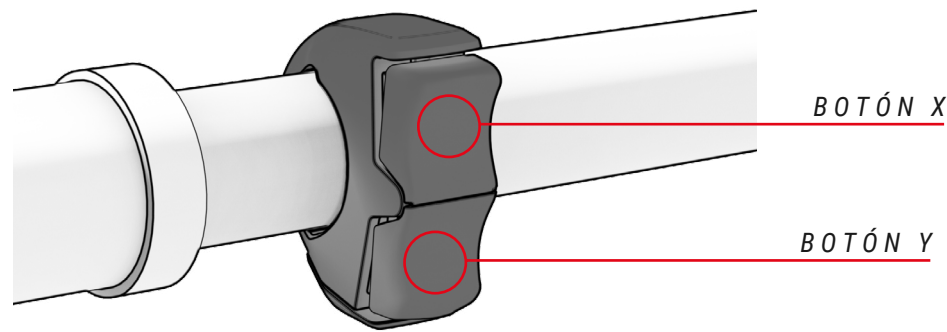

In order to increase the life of the battery and prevent a full discharge which may damage it, the assistance modes are limited based on the state of charge of the battery:

- Battery charge above 20%: 100% of the highest assistance level is available.
- Battery charge between 10% and 20%: assistance level limited to 50% of the highest assistance level.
- Battery charge between 5% and 10%: assistance level limited to 25% of the highest assistance level.
- Battery charge between 1% and 5%: assistance is not permitted. Only the lights can be turned on.

## WALK ASSIST MODE

There is a sixth assistance mode that helps the user transport the bicycle while on foot. To activate the walk assist mode, press and hold the Y button for one second, until the word "Walk" appears on the display. Once the mode has been activated, release the Y button and press it again to start pushing. Press and hold the button to enable the mode and release it to disable it.

## START OF PEDALLING

Before resting your feet on the pedals, you must sit on the saddle and hold the handlebars firmly. Special care should be taken if you start pedalling when using a high assistance mode (TRACK and BOOST modes), as the motor will respond with maximum thrust and you may lose control. To facilitate acceleration, the motor provides an additional initial thrust as soon as you start pedalling. Therefore, minimal force is required to put the bicycle in motion, helping you to join the traffic quickly and safely.

- ⚠ Start pedalling with a short gear ratio (higher gears) and low assistance mode (ECO mode). As well as providing greater control and safety on the bicycle, it requires less energy consumption and, therefore, ensures a longer range. Starting to pedal with a higher assistance mode (TRACK and BOOST modes) may put the user at risk.
- ⚠ When the user pushes the bike while walking alongside it, they must make sure that the system is disconnected.

## DISPLAYING THE BATTERY CHARGE LEVEL

A 100% charge can provide a range of up to 155 km. The battery charge level can be displayed in three ways: from the display, internal battery or a Garmin device. The battery charge level indicator shows the estimated remaining battery capacity in all cases:

- **Display:** the current battery charge level is shown on the upper left part of the display:



- ⚠ The range of the system will vary depending on the following riding conditions, among others: frequent starts and stops, transmission ratio, numerous steep slopes, road surface in poor condition, carrying heavy loads, strong wind coming towards the cyclist, low temperatures, degradation of the battery, use of the built-in lighting system, incorrect tyre pressure, chain or brake settings.

- **Garmin devices:** Garmin devices also display the battery level on the interface:



- **Battery:** the power button on the battery cover features a LED ring that indicates the battery charge level with different colours:

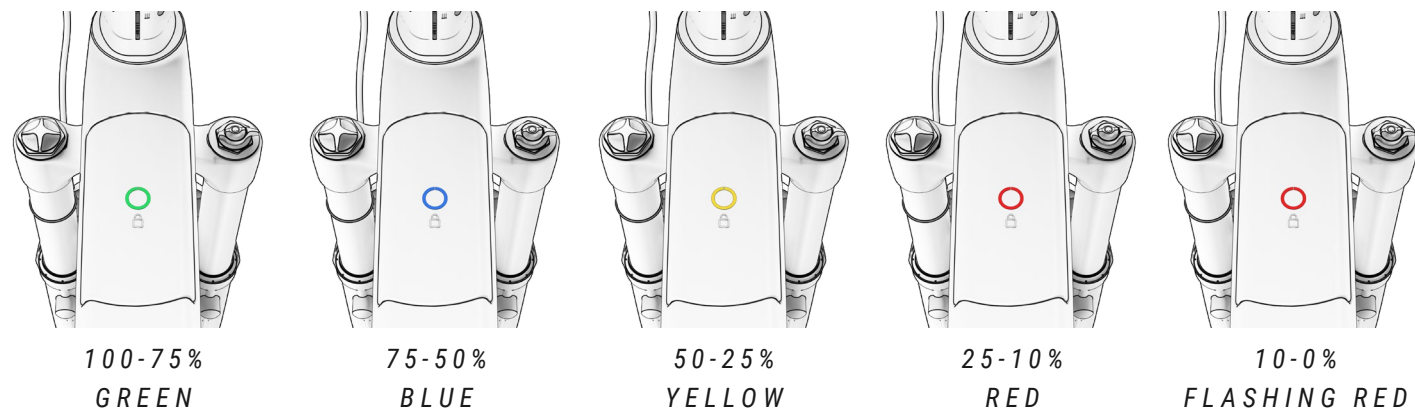

## BATTERY AND CHARGER

The battery that your BH bike is equipped with contains lithium-ion cells and is the most advanced technology available in terms of energy density (energy stored per kilogram of weight and per cm<sup>3</sup> of volume).

Lithium-ion batteries have the following characteristics:

- Their performance decreases in extremely hot or cold environments.
- An additional characteristic of BH's lithium-ion batteries is that they have no "memory effect", and are not affected by incomplete discharging.
- They lose their charge naturally and gradually with use. The battery can be fully discharged (100%) approximately 500 times, with maximum battery deterioration of 20%. In the case of partial discharges, only the discharged part is counted. For example, if you charge the battery every time its charge level falls by 25%, you will be able to charge it to 100% of its initial capacity 2,000 times. In short, the guaranteed durability of the battery with maximum degradation of 20% is at least 20,000 km.

## BATTERY CHARGE LEVEL

Due to its advanced lithium-ion technology, there is no need to wait for the battery to completely discharge before connecting it to the charger. Likewise, it is also not necessary to charge it to 100% before using it again. But bear in mind that, in order to achieve a maximum operating range, a full charge is recommended.

The battery can be charged while mounted on the bicycle and when it is removed from the frame. The steps that must be followed to charge the battery correctly in both cases are described below:

1. TURN OFF THE PEDAL ASSISTANCE SYSTEM.

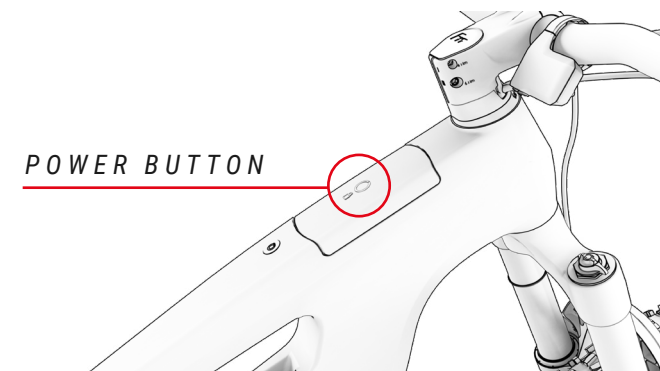

2. OPEN THE COVER WITH THE KEY AND TURN IT 90° FROM ITS STARTING POSITION.

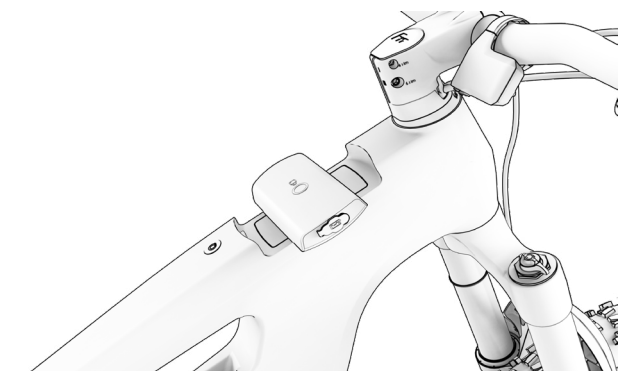

3. PULL UPWARDS TO REMOVE THE BATTERY OR LEAVE IT IN PLACE TO CHARGE IT INSIDE THE FRAME.

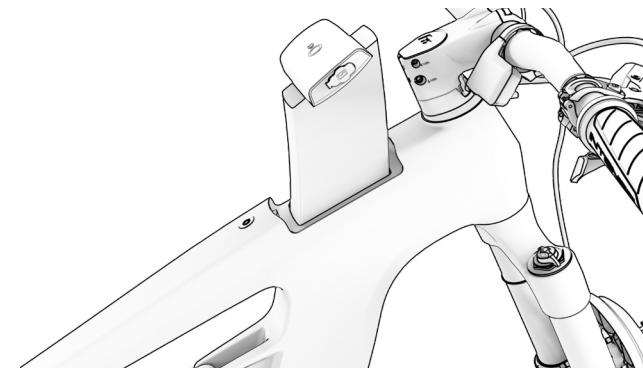

4. OPEN THE CHARGING PORT COVER

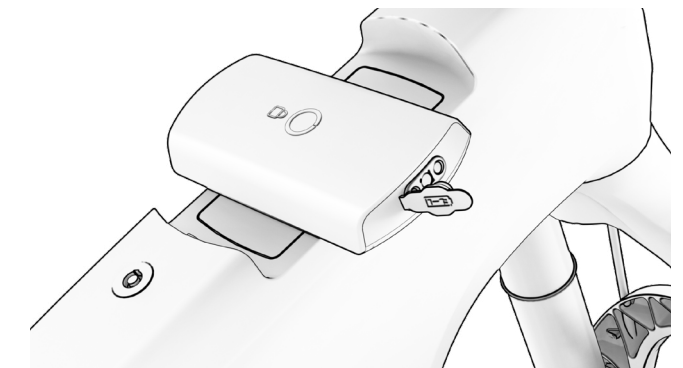

5. CONNECT THE BATTERY CHARGER FIRST AND THEN PLUG INTO THE POWER SOCKET.

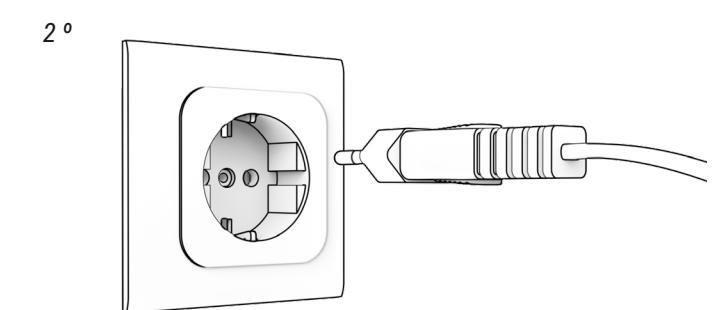
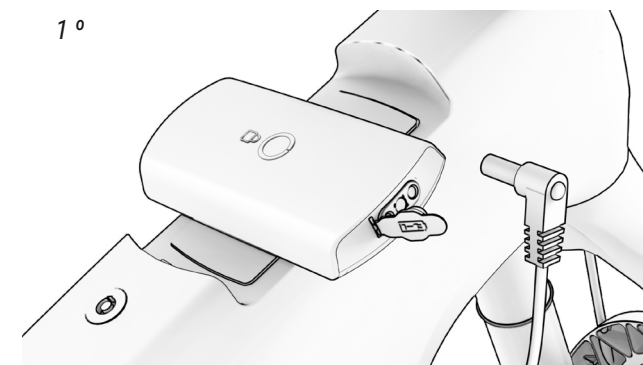

## 6. VIEW THE STATE OF CHARGE AND ERRORS.

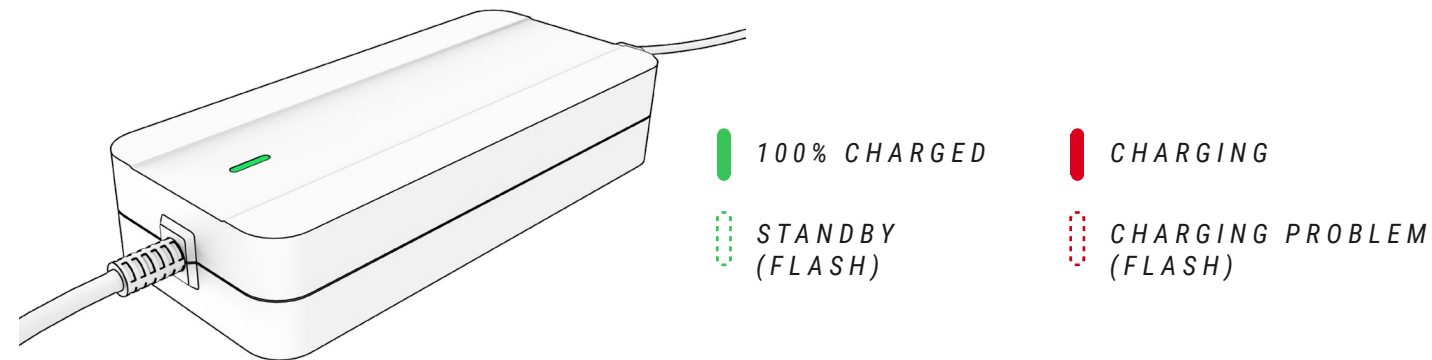

## 7. ALWAYS DISCONNECT THE BATTERY CHARGER FIRST AND THEN REMOVE THE PLUG FROM THE POWER SOCKET.

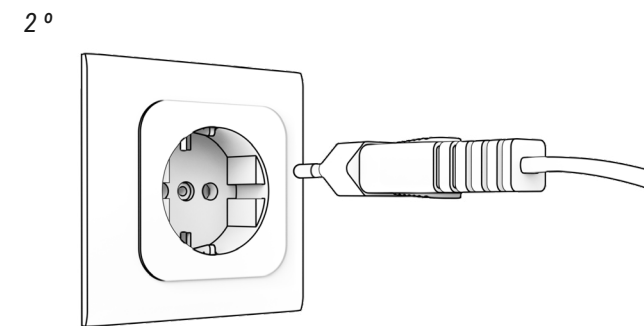
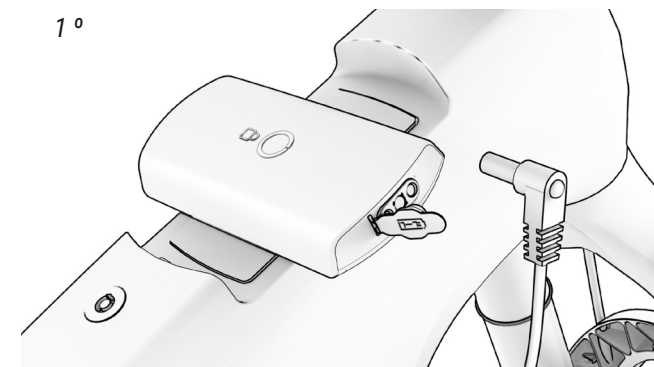

## 8. CLOSE THE CHARGING PORT COVER.

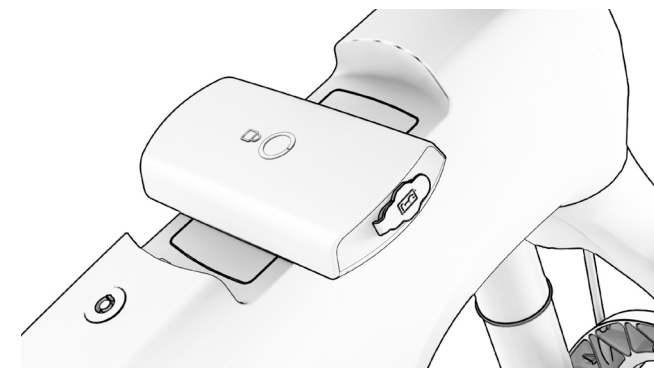

## 9. FIT THE BATTERY INSIDE THE FRAME IF IT HAS BEEN REMOVED AND CLOSE THE COVER BY TURNING IT BACK TO THE INITIAL POSITION.

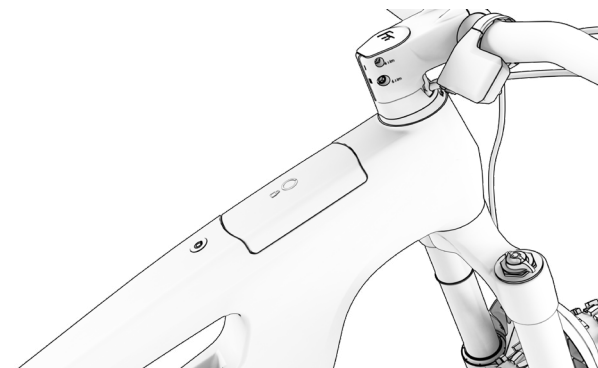

- ⚠ Never charge or use a damaged battery.
- ⚠ Be careful not to touch the charger during the charging process. It may be hot, especially in high ambient temperatures.
- ⚠ If a fault occurs while the battery is being charged, remove the charger's power plug from the socket and wait for the battery to cool down.
- ⚠ Never touch the power plug, charging plug or contacts with wet hands.
- ⚠ Make sure that there is no foreign matter on the battery's contacts before placing it on the bicycle.
- ⚠ Do not connect the charger's power plug to the battery or bicycle's charging port if it is wet or damp. Make sure that you only connect the power plug when the battery or bicycle's charging port is completely dry.
- ⚠ Do not apply excessive force on the power plug or pull the cable with the power plug connected to the battery.
- ⚠ Turn off the pedal assistance system before removing the battery from the bicycle.
- ⚠ Use both hands to remove the battery, taking special care not to drop it. Dropping the battery on your foot could cause injury and may damage the battery.

## ENERGY SAVING MODES

The battery has been designed to ensure a long service life. This is possible thanks to the energy saving modes that prevent inefficient battery consumption:

- **Transport mode:** In order to minimise internal consumption while transporting the bicycle from the factory to the store, the battery is in Transport mode. The user can finally exit this Transport mode by charging the battery to 100% before its first use.

If the battery does not charge fully, the Transport mode will not deactivate, repeatedly entering this mode quickly for its protection. Remember to fully charge the battery to finally deactivate the Transport mode.

- **Standby mode:** In order to minimise internal consumption, the battery automatically switches to Standby mode. This happens automatically when the system detects no charging, no discharging and no communication with the battery for a period of 10 minutes. So, for example, this mode will automatically turn off the control panel after 10 minutes without use, if the user has left it on after parking.

The user can exit this Standby mode by simply turning on the bicycle's control panel.

- **Deep Sleep mode:** In order to protect the battery during long periods of inactivity or storage (for example, during the winter), the battery automatically switches to Deep Sleep mode. This happens automatically when any of the following situations occur:

- If the charge level of the battery is below 1%, the battery goes into Deep Sleep mode when the battery has continuously been in Standby mode for 10 minutes.
- If the charge level of the battery is below 10%, the battery goes into Deep Sleep mode when the battery has continuously been in Standby mode for 48 hours.
- If the charge level of the battery is below 40%: Deep Sleep mode is activated when the battery has continuously been in Standby mode for 14 days.
- If the charge level of the battery is below 80%: Deep Sleep mode is activated when the battery has continuously been in Standby mode for 30 days.

The user can exit this Deep Sleep mode by pressing and holding the battery's SOC button (which checks the charge level) for 5 seconds or by starting to charge the battery with the charger. All LEDs will flash twice in the Standby mode and once in the Deep Sleep mode.

## SHIMANO ETUBE PROJECT APP

The Shimano Etube Project app can be used to customise the assistance level of each pedal assistance mode, among other features. This manual describes the main characteristics and functions of the app. For more information, please refer to Shimano's user manual at:

<https://si.shimano.com/en/um/7J4MA>

This application can also be used to update the firmware of the components and troubleshoot the system if any problem has been detected.

The application can be downloaded from Google Play and Apple Store. Follow these steps to start using the app after downloading it:

1. Open the app on your smartphone.
2. Register your e-bike.
3. Select the device to pair. Press the button on the control panel to activate the connection if it is not available.
4. Register the bicycle with a password of your choice.

After registering the bicycle, you can change the pedal assistance level and configure up to two profiles with specific pedal assistance configurations for each one. Profile 1 is the one assigned by default, but you can switch between profiles on the display:

<https://si.shimano.com/en/pdfs/um/7J4MA/UM-7J4MA-008-ENG.pdf>

## OPERATION WITH THE GARMIN DEVICE

The ANT+ connection to a Garmin device grants you access to additional assistance display and control functions. The Heart Rate strap connects via the Garmin device. The steps that must be followed to connect the main controller to the Garmin device are described below. The image in the sixth step shows that the Garmin device can be used to check the bicycle's battery status and to select the desired pedal assistance level.

1. TAP ON "ADD SENSOR".

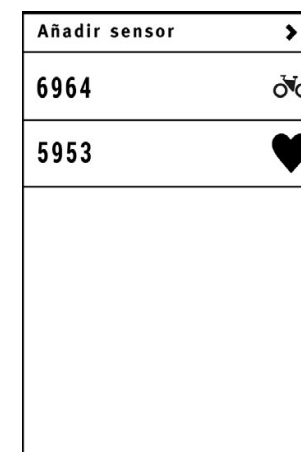

2. TAP ON "E-BIKE".

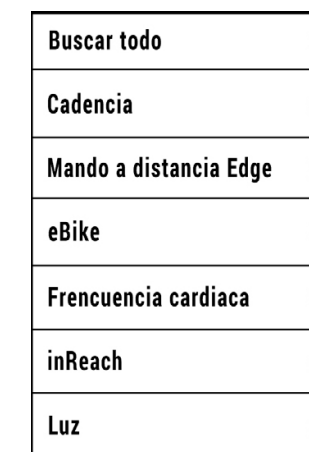

3. PAIR WITH YOUR GARMIN DEVICE.

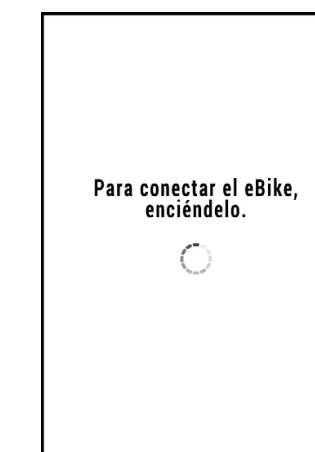

4. SELECT THE E-BIKE.



5. SELECT THE SENSOR YOU HAVE CREATED.

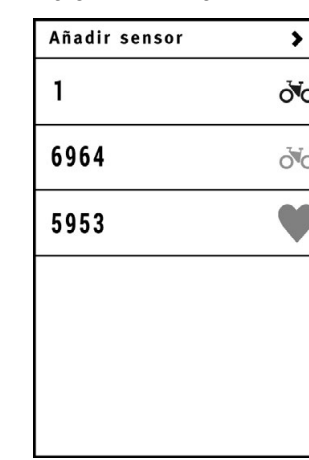

6. GARMIN CONNECTED.



## ELECTRICAL SYSTEM UPDATES

The electrical system updates are installed via the Shimano Etube app when it connects to your bicycle via Bluetooth. If the update process is interrupted for external reasons, such as an incoming call, you must take the bicycle to an official dealer to have the update installed.

You can consult the app's manual at:

<https://si.shimano.com/#/es/iUM/7J4MA/>

The latest updates should be checked and the necessary actions should be carried out during regular maintenance or repairs at an official dealer.

- ⚠ Keep in mind that some actions require advanced knowledge and incorrect handling may cause serious accidents. In addition, incorrect handling will not be covered by the warranty.

## ERRORS OF THE PEDAL ASSISTANCE SYSTEM

The display will also show any error detected in the pedal assistance system. The most common errors are described below. Visit Shimano's portal for more information about all the errors and the latest updates:

<https://si.shimano.com/#/es/iER/STP0A>



### ERROR CODES

Code	Description	Action required
<b>W010</b>	Temperature of the drive unit is higher than it is during times of normal operation.	Stop using the assistance function until the temperature of the drive unit drops.
<b>W011</b>	The travelling speed cannot be detected.	Check that the speed sensor is installed properly.

Code	Description	Action required
<b>W013</b>	Initialisation of the torque sensor was not completed successfully.	With your foot off the pedal, press the battery power button and turn on the power again.
<b>W032</b>	An electronic derailleur may have been installed in place of a mechanical derailleur.	Reinstall the derailleur the system is configured to support.

If the error appears on the full screen, press the battery activation button and remove the battery from the frame to restore the display.

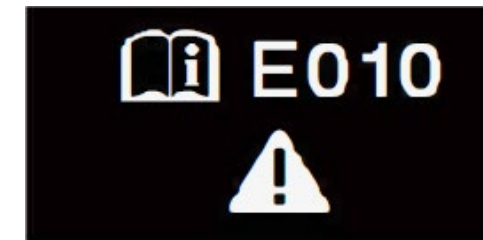

### ERROR CODES

Code	Description	Action required
<b>E010</b>	A system error was detected.	Press the battery power button to turn it on again.
<b>E011</b>	An error occurred in the system's operation.	Turn on the power again.
<b>E013</b>	An anomaly was detected in the drive unit's firmware.	-
<b>E014 (EA050)</b>	The speed sensor may have been installed in the wrong position.	-
<b>E020</b>	Communication between the battery and drive unit was detected.	Check that the cable between the drive unit and battery is properly connected.
<b>E021</b>	Battery connected to drive unit complies with system standards but is not supported.	Press the battery power button to turn it on again.
<b>E022</b>	Battery connected to drive unit does not comply with the system standards.	Press the battery power button to turn it on again.
<b>E033</b>	The current firmware does not support the system's operation.	Connect to E-TUBE CONNECT and update the firmware for the entire unit.
<b>E043</b>	Part of the bicycle computer's firmware may be damaged.	-



## 07 SIZES AND DIMENSIONS

### DOUBLE SUSPENSION

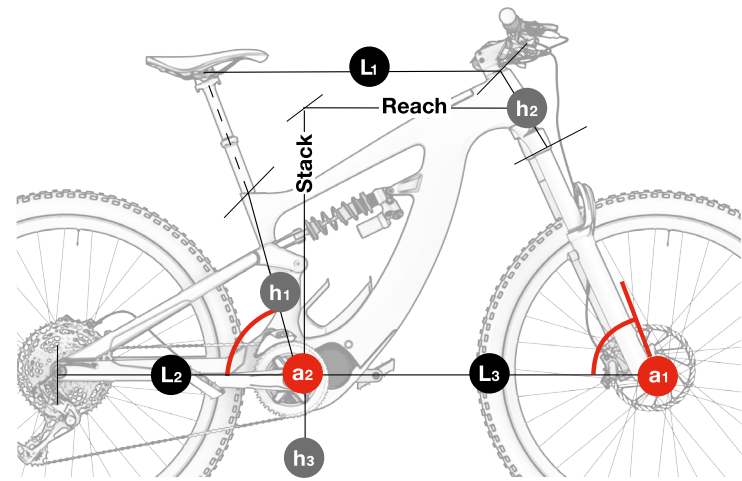

#### ES992

### XTEP LYNX CARBON 9.9 PRO

	h1	h2	h3	L1	L2	L3	a1	a2	Stack	Reach
SM	400	100	351	593	464	749	65	73,8	619	425
MD	400	110	351	613	464	754	66	73,8	633	435
LA	440	125	351	633	464	773	66	73,8	648	450
XL	480	140	351	648	464	794	66	73,8	662	465

#### ES982

### XTEP LYNX CARBON 9.8 PRO

	h1	h2	h3	L1	L2	L3	a1	a2	Stack	Reach
SM	400	100	351	593	464	749	65	73,8	619	425
MD	400	110	351	613	464	754	66	73,8	633	435
LA	440	125	351	633	464	773	66	73,8	648	450
XL	480	140	351	648	464	794	66	73,8	662	465

#### ES972

### XTEP LYNX CARBON 9.7 PRO

	h1	h2	h3	L1	L2	L3	a1	a2	Stack	Reach
SM	400	100	351	593	464	749	65	73,8	619	425
MD	400	110	351	613	464	754	66	73,8	633	435
LA	440	125	351	633	464	773	66	73,8	648	450
XL	480	140	351	648	464	794	66	73,8	662	465

#### ES882

### XTEP LYNX CARBON 8.8 PRO

	h1	h2	h3	L1	L2	L3	a1	a2	Stack	Reach
SM	400	100	345	590	465	740	66	74,5	601	430
MD	400	110	345	610	465	745	67	74,5	615	440
LA	440	125	345	630	465	764	67	74,5	630	455
XL	480	140	345	648	465	785	67	74,5	644	470

#### ES872

### XTEP LYNX CARBON 8.7 PRO

	h1	h2	h3	L1	L2	L3	a1	a2	Stack	Reach
SM	400	100	345	590	465	740	66	74,5	601	430
MD	400	110	345	610	465	745	67	74,5	615	440
LA	440	125	345	630	465	764	67	74,5	630	455
XL	480	140	345	648	465	785	67	74,5	644	470

## 08 TECHNICAL SPECIFICATIONS

### GENERAL SPECIFICATIONS

Characteristics	Models	Specification
<b>Frame materials</b>		
<b>Front triangle</b>	All	Carbon
<b>Swingarm (chainstays and seat posts)</b>	ES992 / ES882	Carbon
	ES982 / ES972 / ES872	Aluminium alloy
<b>Tie rod</b>	All	Carbon
<b>Recommended use</b>	ES992 / ES982 / ES972	Enduro
	ES882 / ES872	Trail
<b>Sizes</b>	All	S, M, L, XL
<b>Suspension design</b>	All	Double, Split Pivot system
<b>Fork travel</b>	ES992 / ES982 / ES972 /	160
	ES882 / ES872	140
<b>Maximum fork length (axle to crown)</b>	All	580mm
<b>Fork offset</b>	All	Contact the model's supplier.
<b>Shock absorber dimensions</b>	All	Contact the model's supplier.
<b>Compatibility with spring shock absorbers</b>	All	Depends on the shock absorber and spring dimensions. Contact the manufacturer.
<b>Steering</b>	All	1.5" - 1 1/8" Steerer
<b>Chain line</b>	All	53mm
<b>Wheel size</b>	All	29"
<b>Maximum size of the rear tyre</b>	All	2.4" (61mm)
<b>Maximum size of the front tyre</b>	All	Depends on the fork.

## GENERAL SPECIFICATIONS

Characteristics	Models	Specification
Speed magnet assembly	All	Center Lock rotor. On the brake disc.
Standard rear axle	All	Boost 12x148
Rear axle pitch thread	All	1mm
Length of the rear axle	All	192mm
Seat post diameter	All	31.6mm
Seat post clamp diameter	All	Built-in
Maximum insertion length of the seat post		
S	All	200mm
M	All	220mm
L	All	240mm
XL	All	240mm
Compatible with a telescopic seat post with internal cabling	All	Yes
Front derailleur	All	No. Only 1X
Maximum chain ring size	All	38t
Minimum chain ring size	All	34t
Compatible with the oval chain ring	All	No
Type of brakes	All	Disc brakes
Standard rear brake calliper	All	Post Mount
Maximum rear disc size	All	203mm
Minimum rear disc size	All	180mm
Compatible with chain guides	All	Yes
ICGS	All	No
Cabling	All	Internal through DT and CS. Full housing
Compatible with left rear brake cabling	All	Yes

Characteristics	Models	Specification
Bottle holder	All	All sizes. Standard bottle holder.
Potentiometer compatibility	All	No
Compatible with trailers	All	No
Pannier rack assembly	All	No
Mudguard assembly	All	No
Child seat assembly	All	No
Maximum recommended weight (cyclist+equipment+bags)	All	165Kg

## SHIMANO EP8 MOTOR SPECIFICATIONS

Characteristics	Specification
Rated power	250W
Voltage	36V
Type	Brushless DC
Assistance	Up to 25 km/h
Maximum torque	85Nm
Weight	2600g
Pedal assistance modes	4
Walk assist	Yes (press Y button 1s to activate and hold down to assist)
Cadence range	130/min.
Sensors	Cadence
	Torque
	Speed
System technology	CAN bus

## SHIMANO EM800 CONTROLLER SPECIFICATIONS

Characteristics	Specification
Functions	Change of assistance mode.

## BATTERY SPECIFICATIONS

Characteristics	Specification
Voltage	36V
Capacity	720WH
Weight	3620g
Cell pack	10S4P
Charge level	With the battery mounted on the frame or outside the frame.
Dimensions	586.3x80x45mm
Connection	Cable connected to the motor, charging port and control panel.
Watertightness	IP65

## CHARGER SPECIFICATIONS

Characteristics	Specification
Input	100-240V. 50-60Hz. AC
Output	42V
Charging current	4A
Charging temperature range	0°C - 40°C
Display of the charging progress	With the LED built into the charger

## SPEED SENSOR SPECIFICATIONS

Characteristics	Specification
Assembly	Built into the left chainstay. Internal cabling.
Magnet	On the brake disc.

## EM800 DISPLAY SPECIFICATIONS

Characteristics	Specification
Functions	Display of errors. Display of the selected assistance mode. Display of trip information.

# 09 ASSEMBLY AND SPARE PARTS

## DIMENSIONS OF THE STEERING TUBE

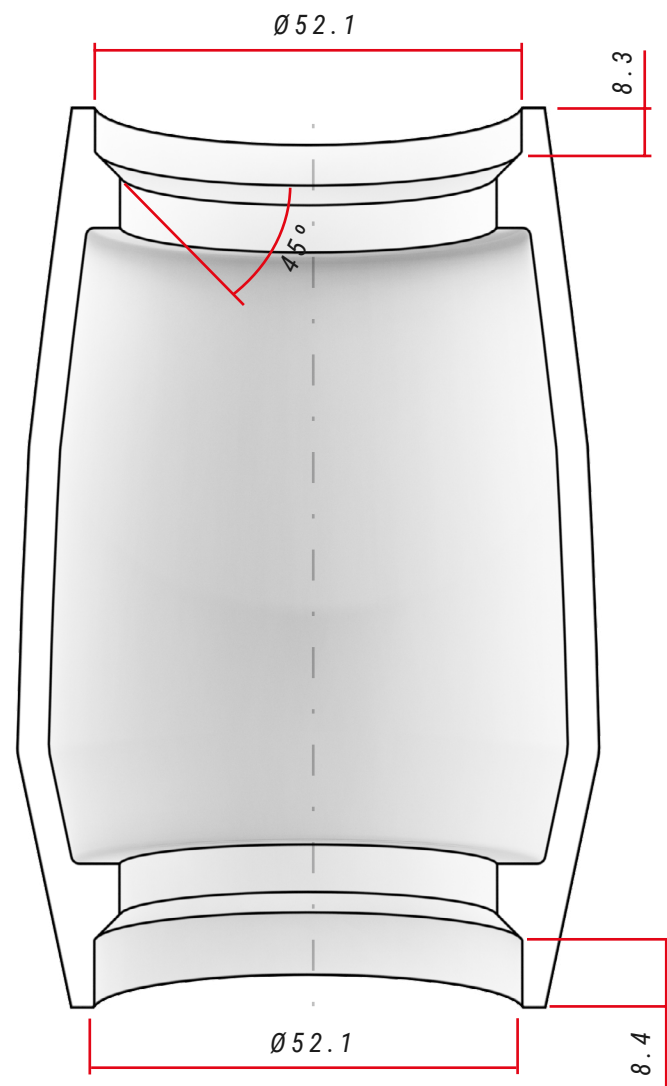

### STEERING SPECIFICATIONS

Type	Contact angle with the compression ring / fork track	Bearing dimensions
Upper	1-1/8" Steerer	42x52x7
Lower	1,5" Steerer	40x52x7, R2

## HEADSET ASSEMBLY

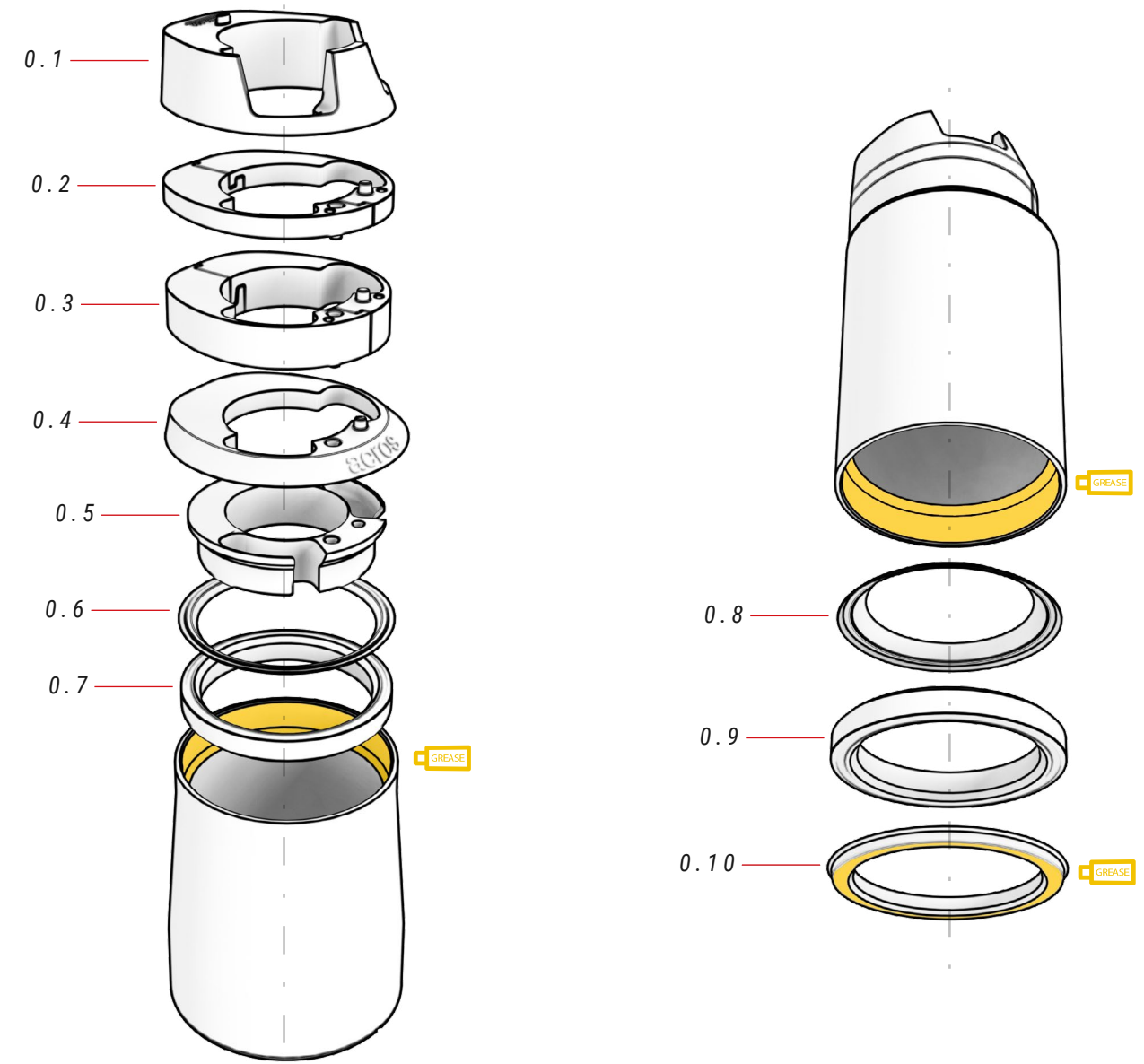

### 00 HEADSET

ref.: 383253600

No.	Item	Quantity
0.1	Top cover, cable insertion point	1
0.2	5 mm spacer (2 parts)	1
0.3	10 mm spacer (2 parts)	1
0.4	Steering tube cover	1
0.5	Cable routing ring	1

No.	Item	Quantity
0.6	Sealing ring	1
0.7	Angular contact bearing 42x52x7	1
0.8	Lower sealing ring	1
0.9	Angular contact bearing 40x52x7	1
0.10	Sealing ring 1.5"	1

## FIT STEM ASSEMBLY

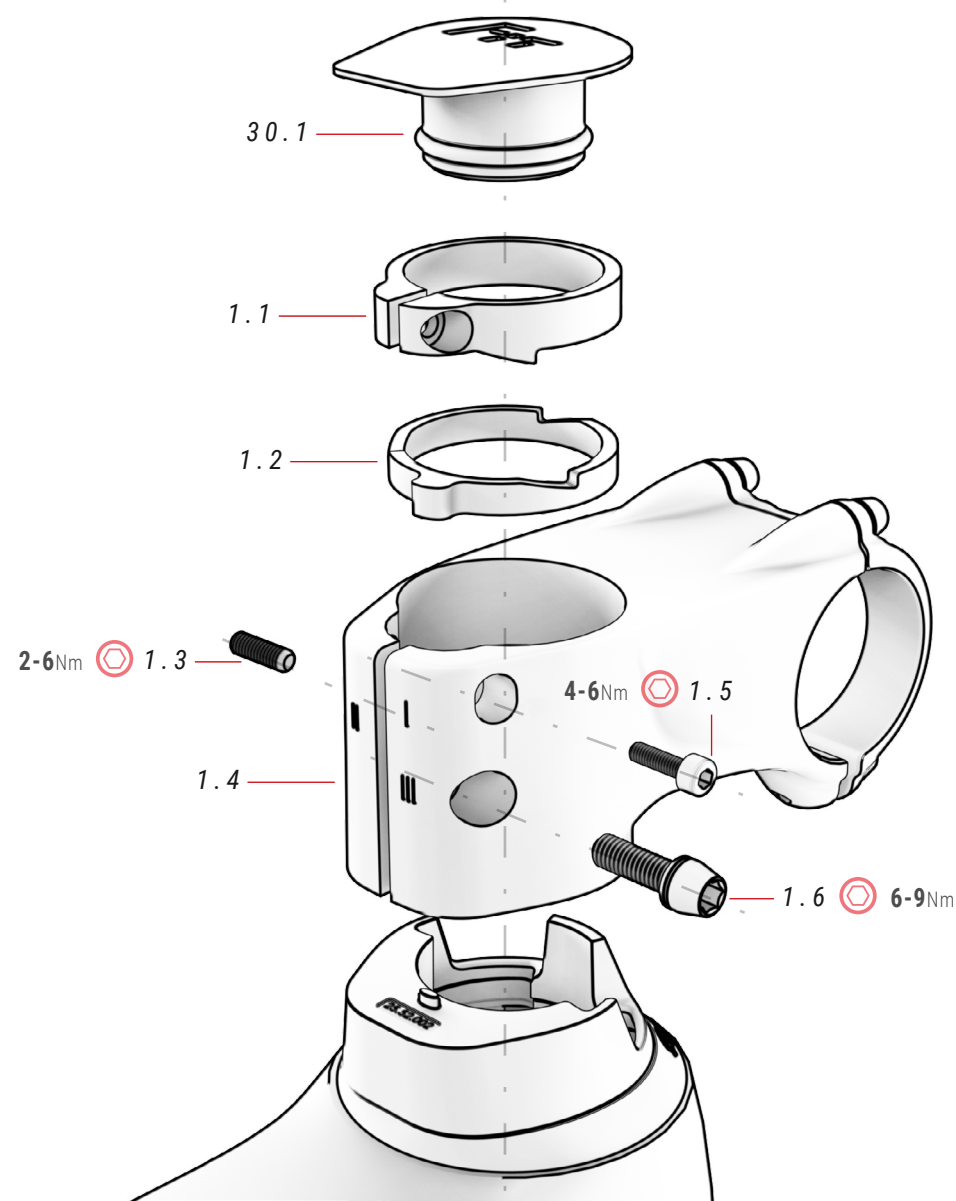

### 01 FIT STEM

ref.: 384612600

No.	Item	Quantity
1.1	Top washer	1
1.2	Bottom washer	1
1.3	Stay bolt	1
1.4	FIT stem	1

FIT STEM ASSEMBLY  
INSTRUCTION VIDEO



0

<https://youtu.be/hJOCBBYKQk>

⚠ Thanks to the washer system (1.1 and 1.2), the FIT.1 stem eliminates all gaps without using a spindle. Carefully follow all of the steps described in this video to mount the stem correctly and prevent accidents.

No.	Item	Quantity
1.5	Bolt	1
1.6	Bolt	1

### 30 FIT STEM CAP

ref.: 363293900

No.	Item	Quantity
30.1	FIT stem cap	1

## MOUNTING THE BH FIT TOOL

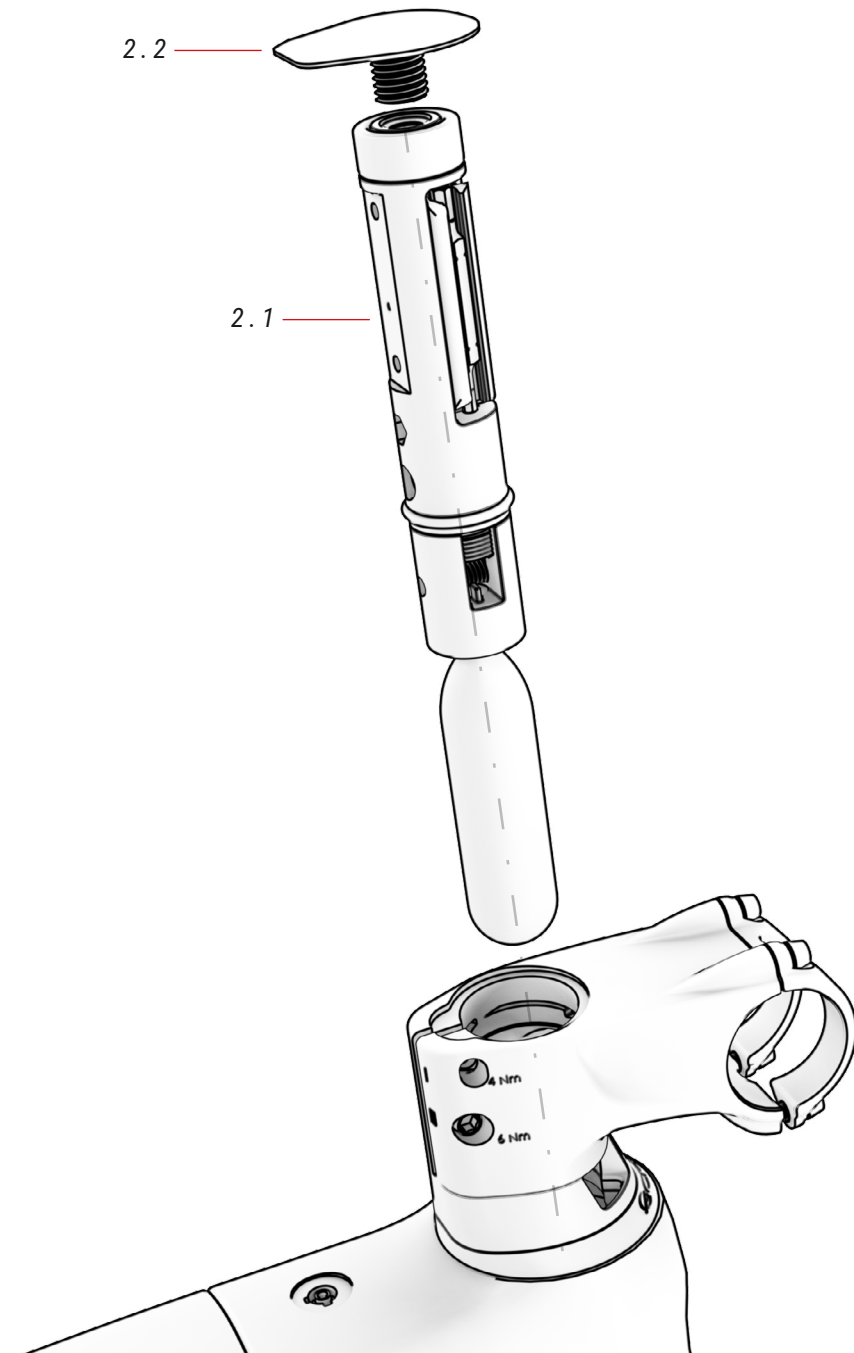

### 02 FIT TOOL

No.	Item	Quantity
2.1	FIT (sold separately)	1
2.2	Threaded cover for tool. FIT	1

## MOUNTING THE BUILT-IN LOCK ON THE SADDLE'S SEAT POST

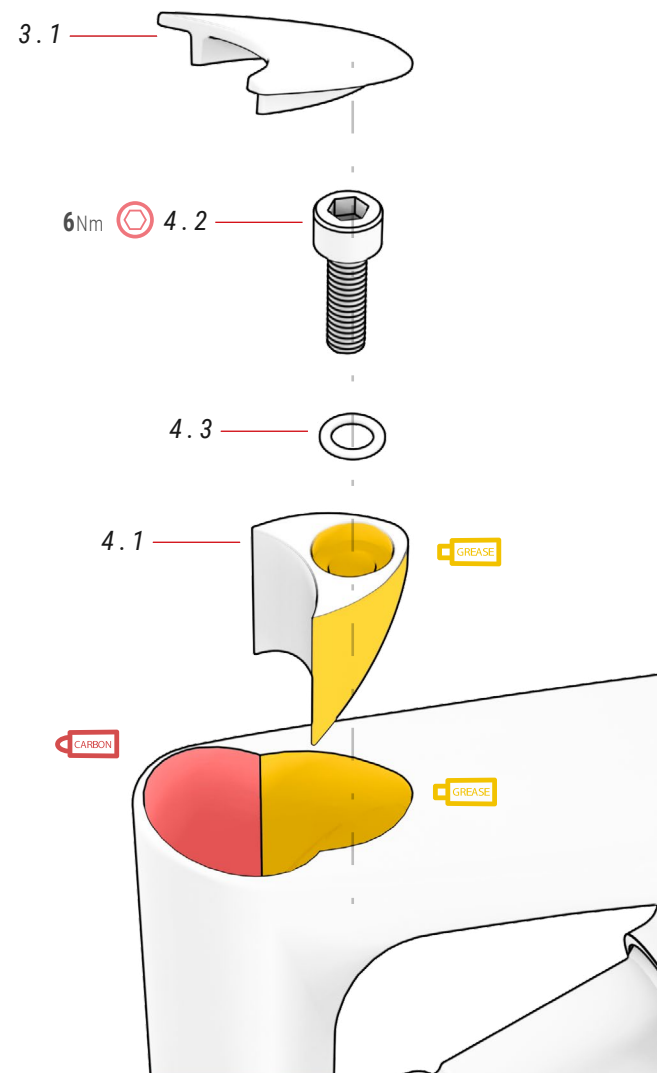

### 03 SEAT POST CLAMP PLUG ref.: 381538900

No.	Item	Quantity
3.1	Seat post cover	1

### 04 CLAMP ref.: 386132900

No.	Item	Quantity
4.1	Clamp	1
4.2	Bolt M6xP1.0x25 mm	1
4.3	Washer	1

## REAR AXLE SPLIT PIVOT AND HANGER

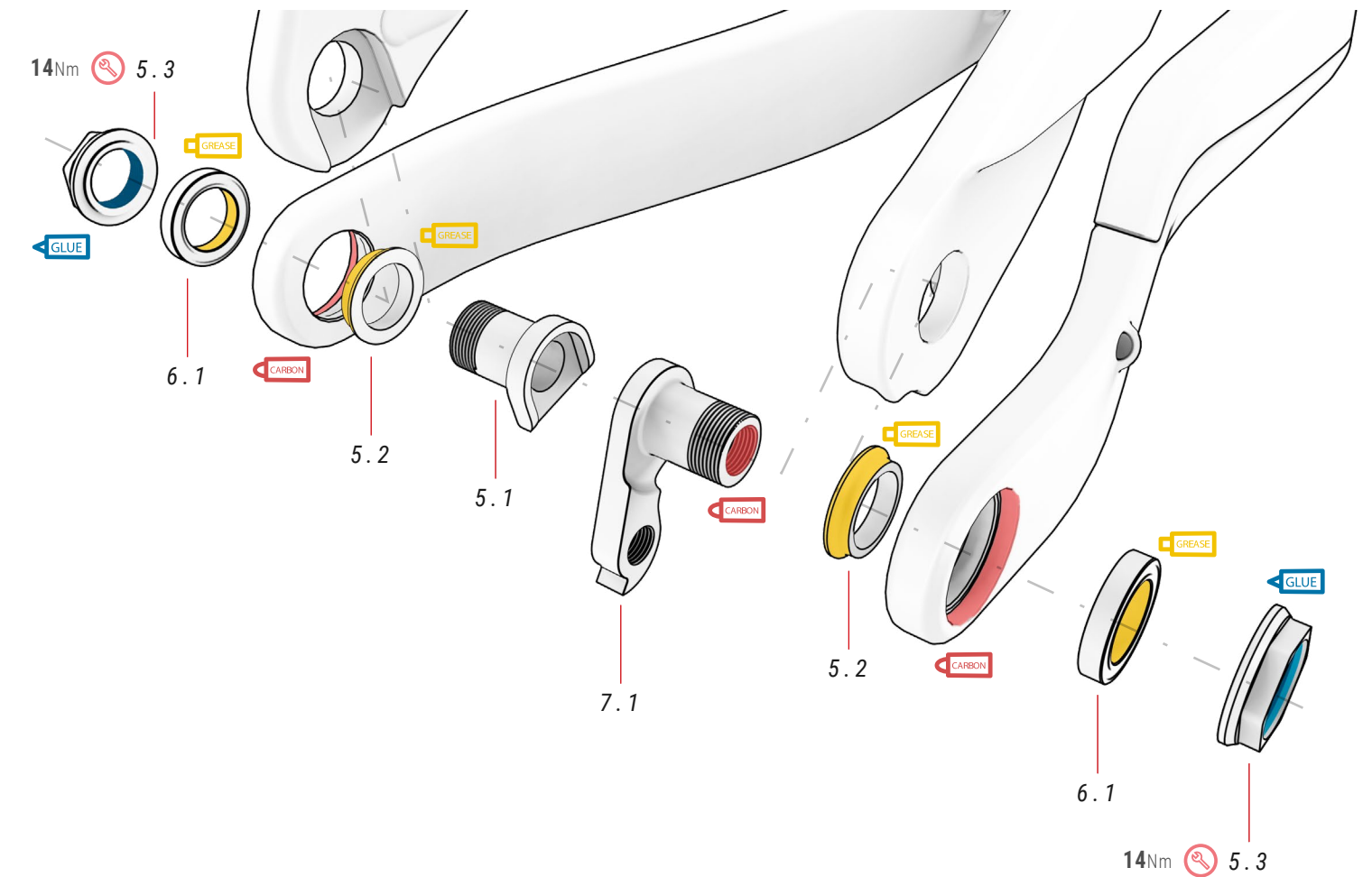

### 05 SPLIT PIVOT ref.: 381215400

No.	Item	Quantity
5.1	Bolt set	1
5.2	Washer	2
5.3	Dropout nut	2

### 06 SPLIT PIVOT BEARING ref.: 381215500

No.	Item	Quantity
6.1	Dropout bearing Ø17xØ26x5 mm	2

### 07 REAR HANGER ref.: 381521400

No.	Item	Quantity
7.1	Rear hanger	1

# MAIN PIVOT AXLE

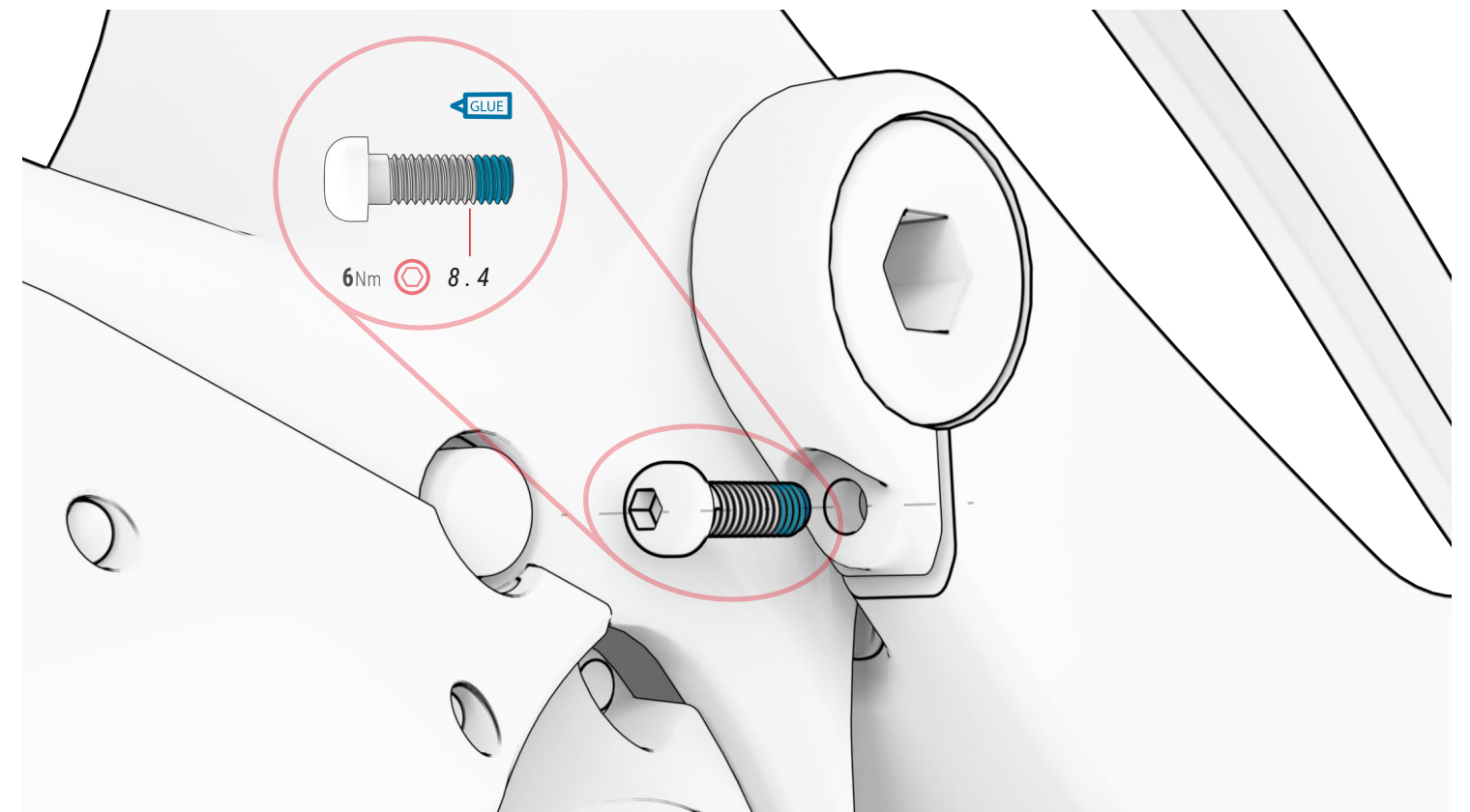
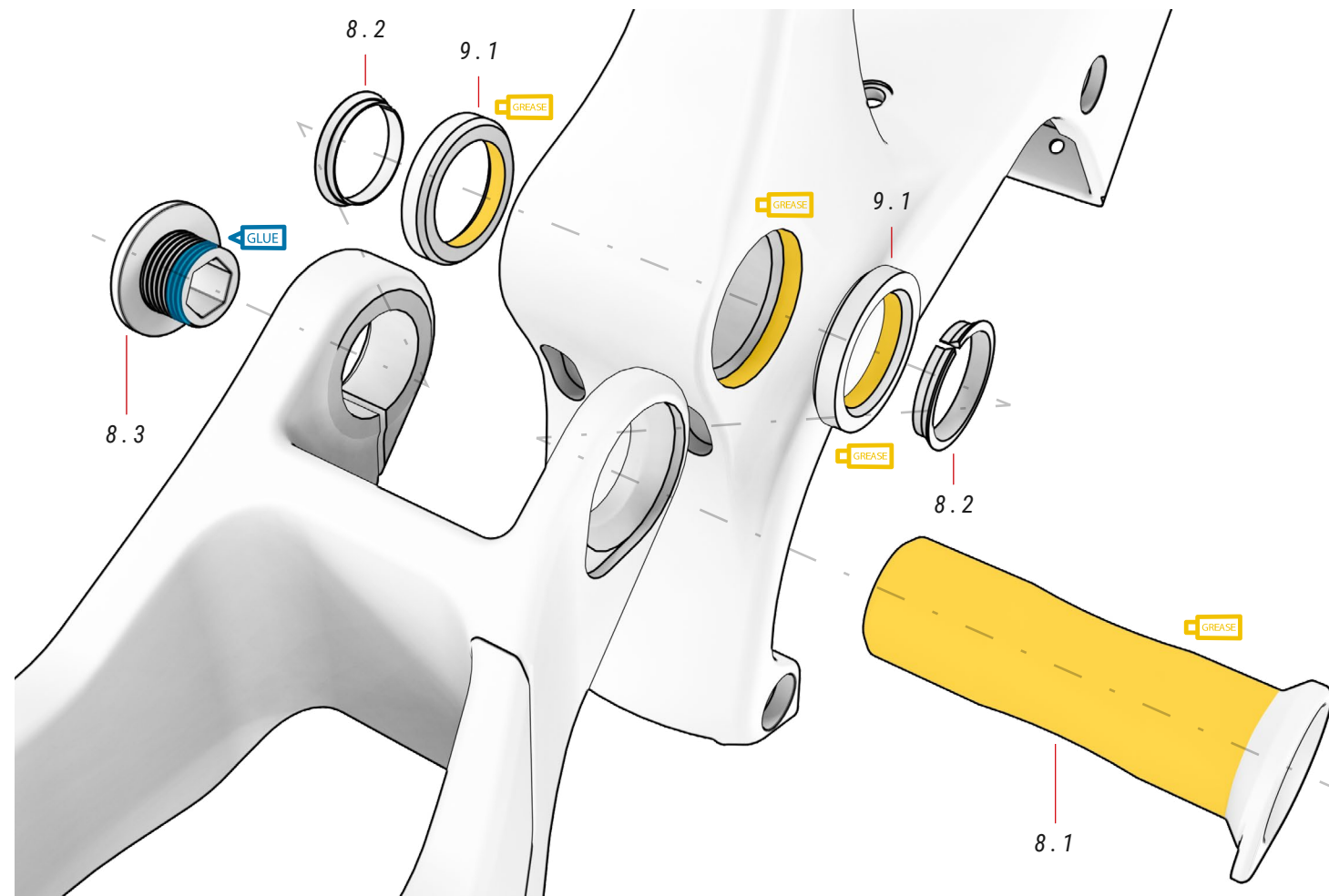

⚠ The maximum tightening torque of part 8.2 is 2 Nm, since it is designed to prevent gaps. Part 10.2 will be used to secure part 8.2.

## 08 MAIN PIVOT AXLE ref.: 381215800

No.	Item	Quantity
8.1	Thru-axle	1
8.2	Compression washer	2
8.3	Bolt	1
8.4	Bolt M6xP1.0x20 mm	1

## 09 MAIN PIVOT BEARING ref.: 381215900

No.	Item	Quantity
9.1	Bearings Ø27.15xØ38x6.5 mm 36X45° 1°HS	2

## EXPLODED VIEW OF THE ROCKER

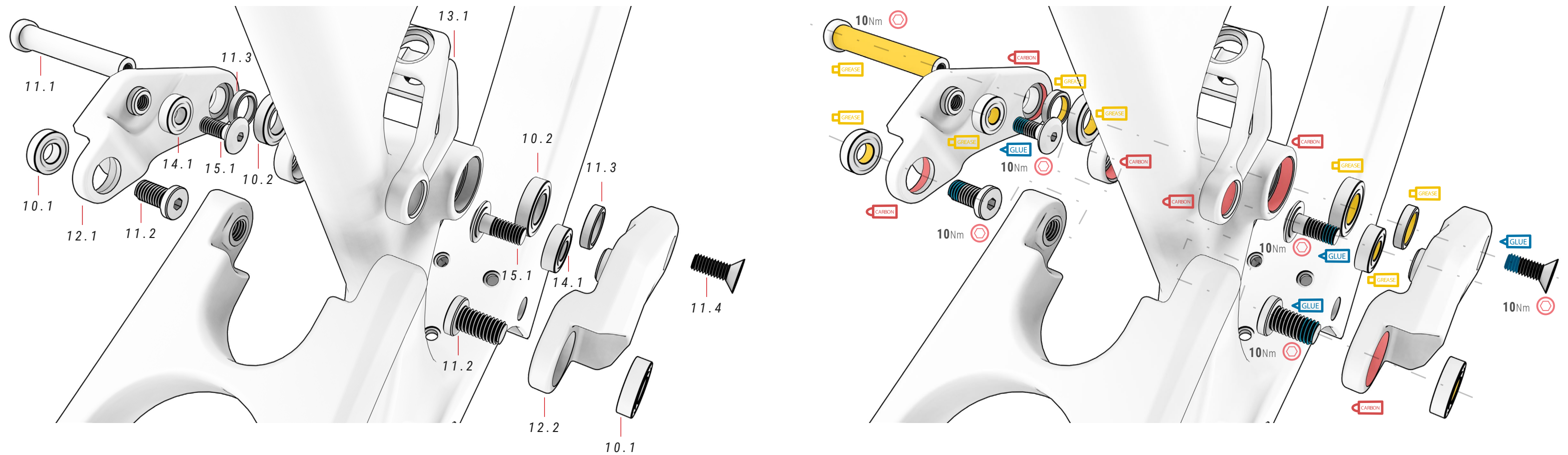

### 10 SEAT STAYS-ROCKER BEARING ref.: 381215700

No.	Item	Quantity
10.1	Bearings Ø10xØ22x6 mm	2
10.2	Bearings Ø15xØ28x7 mm	2

### 11 ROCKER AXLE AND BOLT ref.: 381215600

No.	Item	Quantity
11.1	Thru-axle M8xP1.25x86 mm	1
11.2	Bolt M10xP1.5x18 mm	2
11.3	Washer Ø15.2xØ21x5 mm	2
11.4	Bolt M8xP1.25x20 mm	1

### 12 ROCKER SET ref.: 341103000

No.	Item	Quantity
12.1	Left rocker	1
12.2	Right rocker	1

### 13 CLEVIS ref.: 391738000

No.	Item	Quantity
13.1	Clevis	1
13.2	Clevis bolt	1

### 14 CLEVIS BEARING ref.: 381216300

No.	Item	Quantity
14.1	Bearings Ø8xØ19x6 mm	2

### 15 CLEVIS BOLT SET ref.: 381216400

No.	Item	Quantity
15.1	Bolts M8xP1.25x21 mm	2



## SHOCK ABSORBER ASSEMBLY

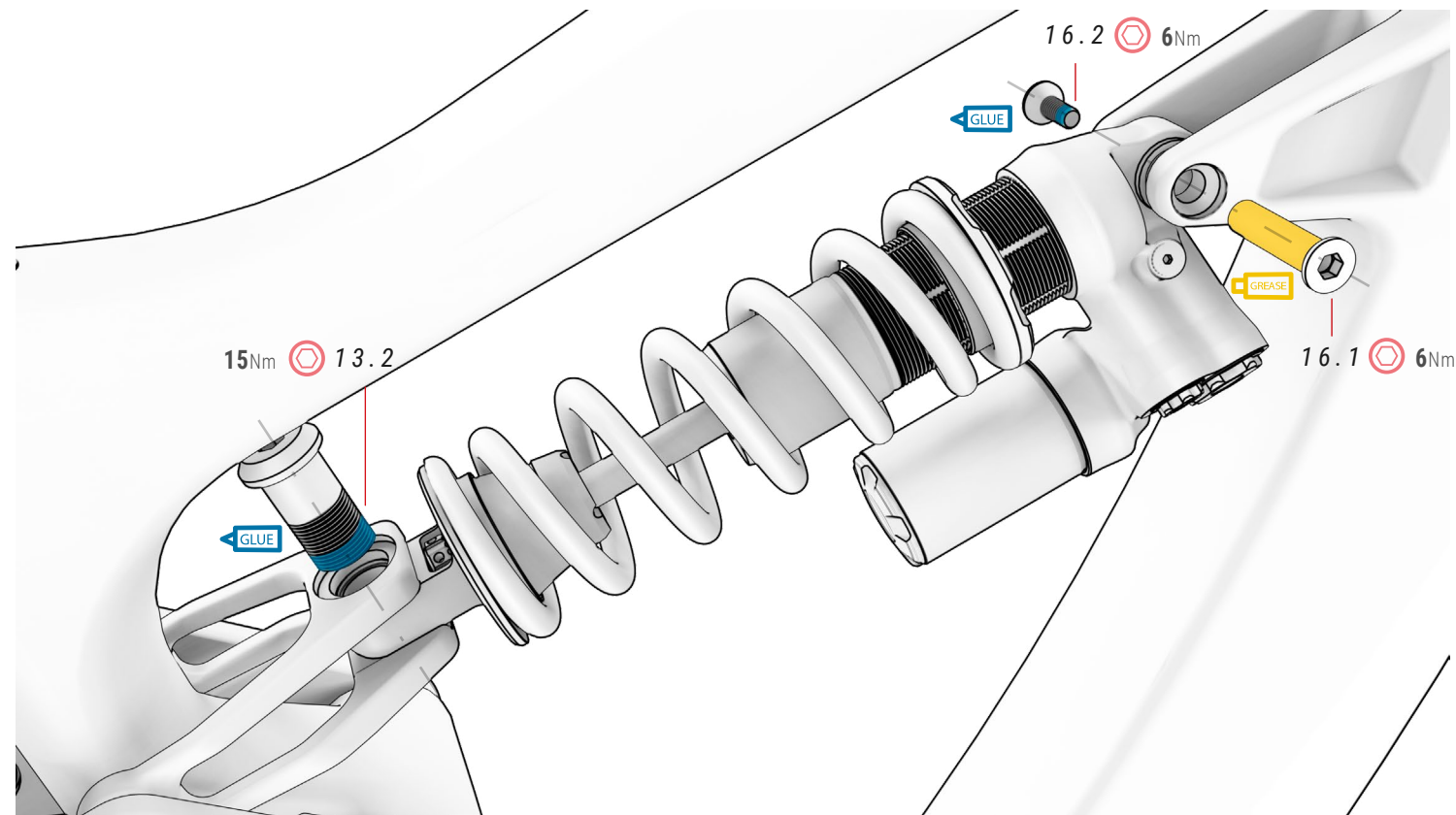

### 13 CLEVIS ref.: 391738000

No.	Item	Quantity
13.1	Clevis	1
13.2	Clevis bolt	1

### 16 SHOCK UPPER FIXING AXLE AND BOLT ref.: 381216000

No.	Item	Quantity
16.1	Shock absorber axle M6xP1.0x33 mm	1
16.2	Bolt M6xP1.0x17 mm	1

## MOTOR COVER

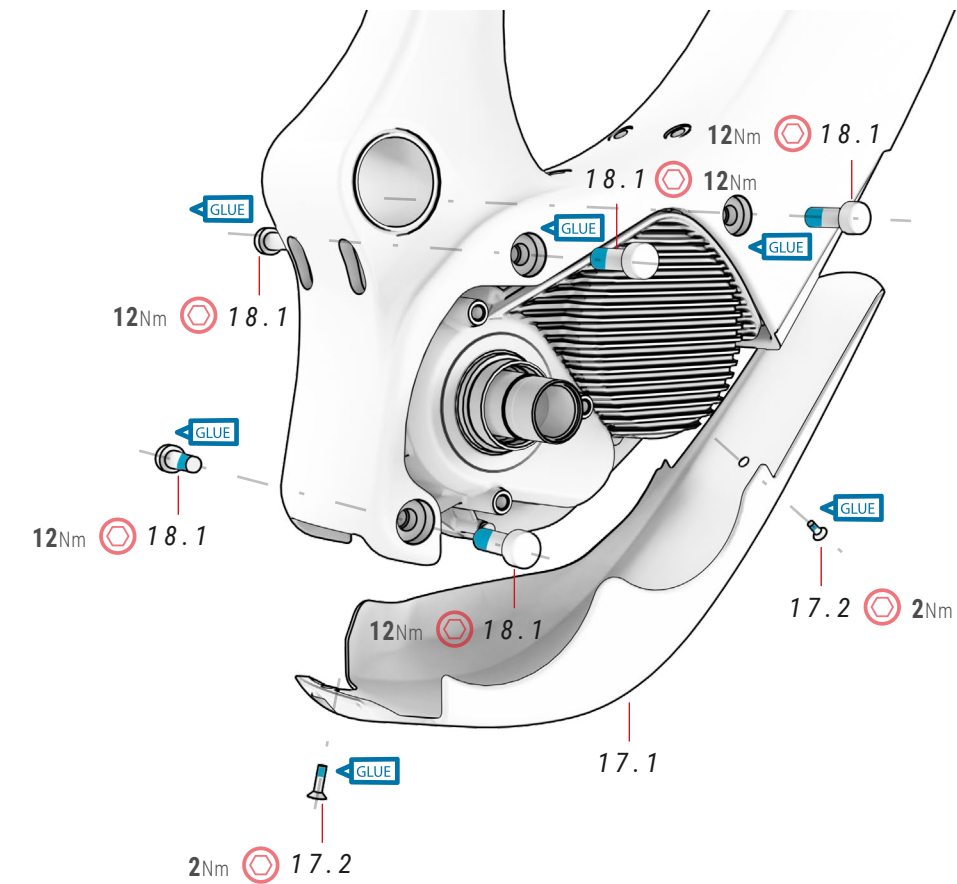

### 17 COVER ref.: 393232600

No.	Item	Quantity
17.1	Motor cover	1
17.2	Motor cover bolts M4xP0.7x10 mm	2

### 18 MOTOR BOLTS

No.	Item	Quantity
18.1	Motor bolt	6

## MOTOR COVER

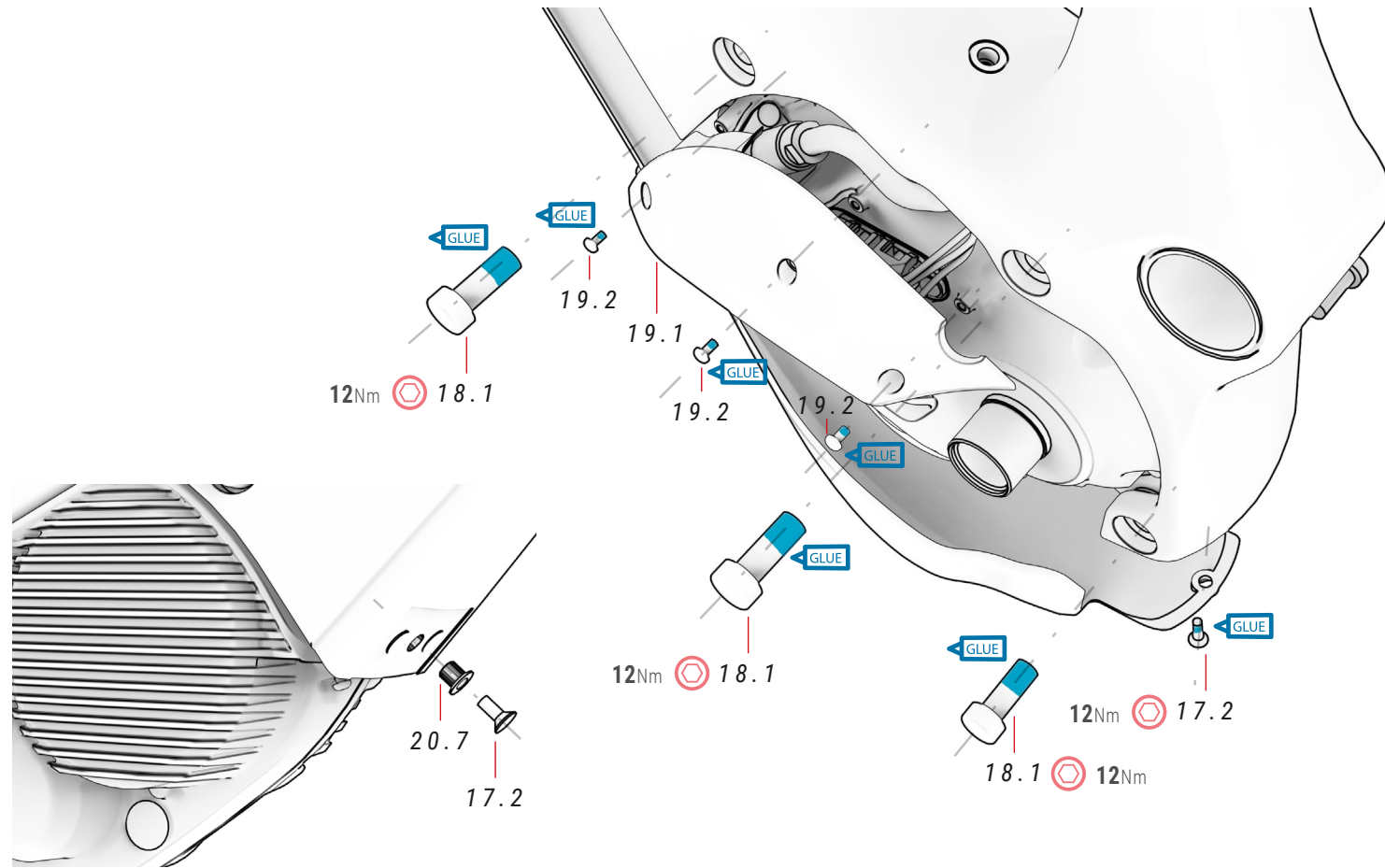

### 17 COVER

ref.: 393232600

No.	Item	Quantity
17.1	Motor cover	1
17.2	Motor cover bolts M4xP0.7x10 mm	2

### 18 MOTOR BOLTS

No.	Item	Quantity
18.1	Motor bolt	6

### 19 SIDE MOTOR COVER

No.	Item	Quantity
19.1	Side motor cover	1
19.2	Side motor cover bolt	3

## BATTERY BRACKET

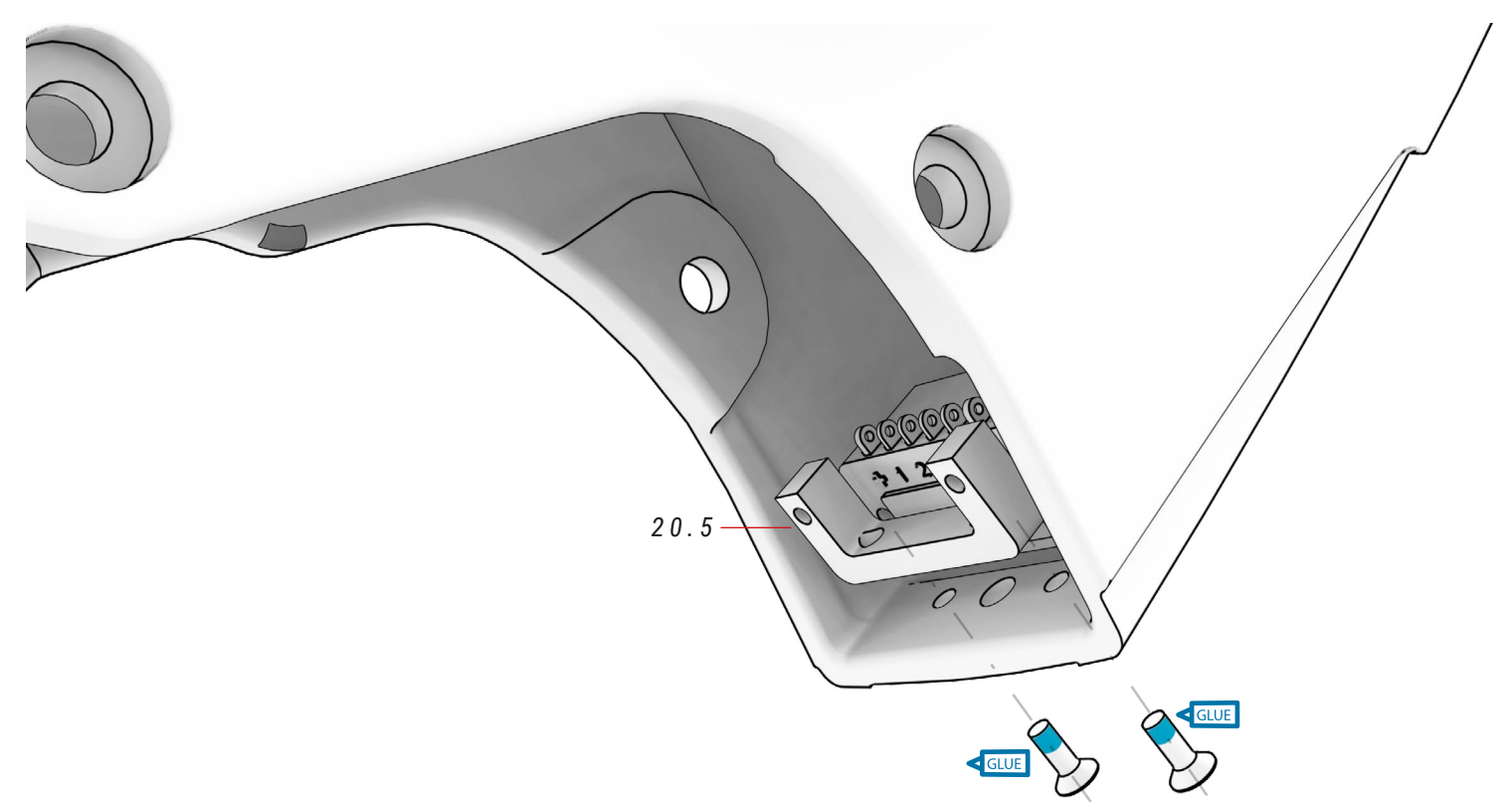

### 20 PLASTIC CAP SET

ref.: 381216100

No.	Item	Quantity
20.1	Bolt	2
20.2	Cable guide on the front triangle	2
20.3	Cable guide on the right chainstay	1
20.4	Cable guide on the left chainstay	1
20.5	Battery bracket	1
20.6	Bottle holder bolts	3
20.7	Bolt fastener	1
20.8	Rear brake stay bolt	2

## PROTECTOR

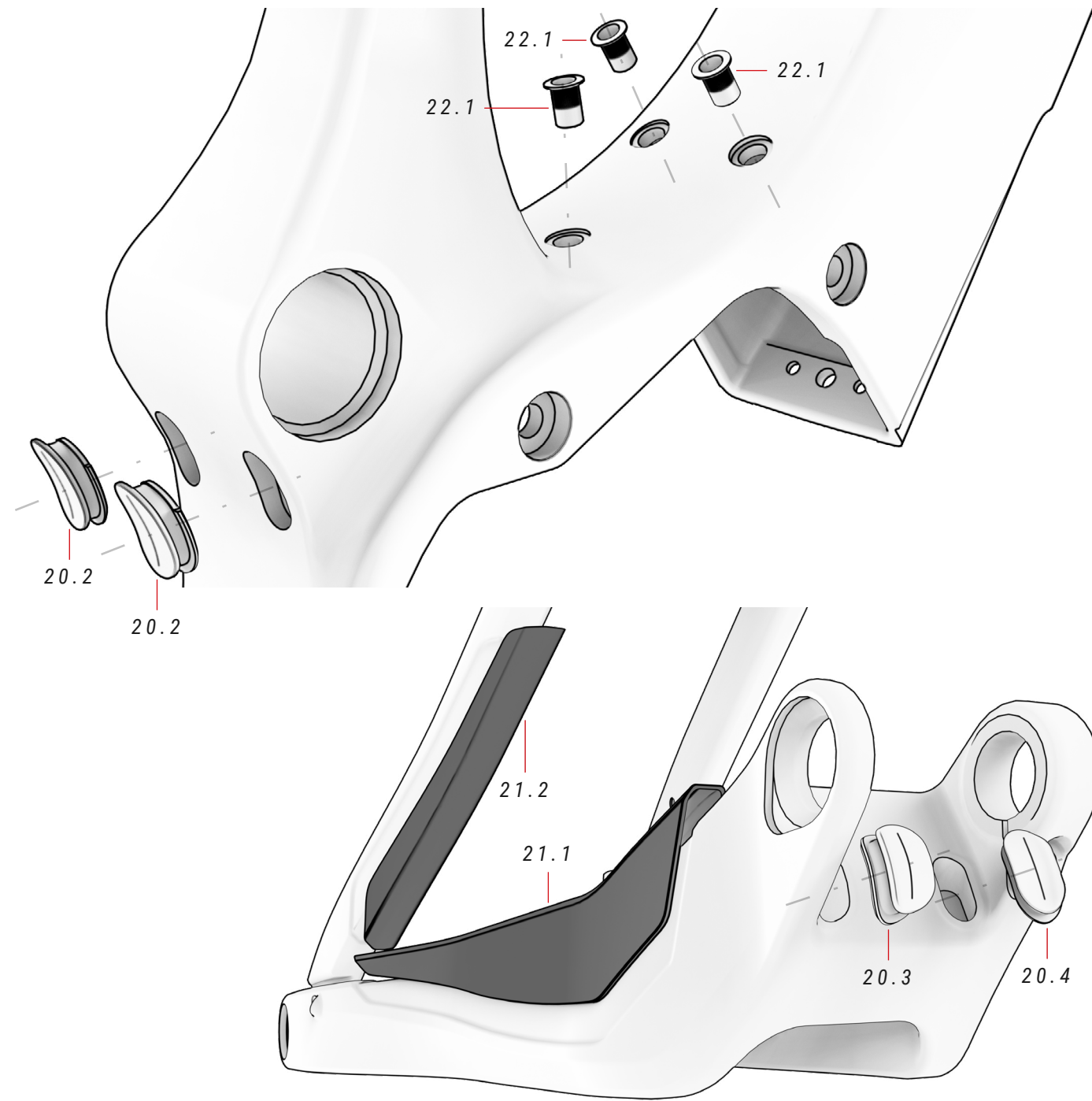

## BOTTLE HOLDER

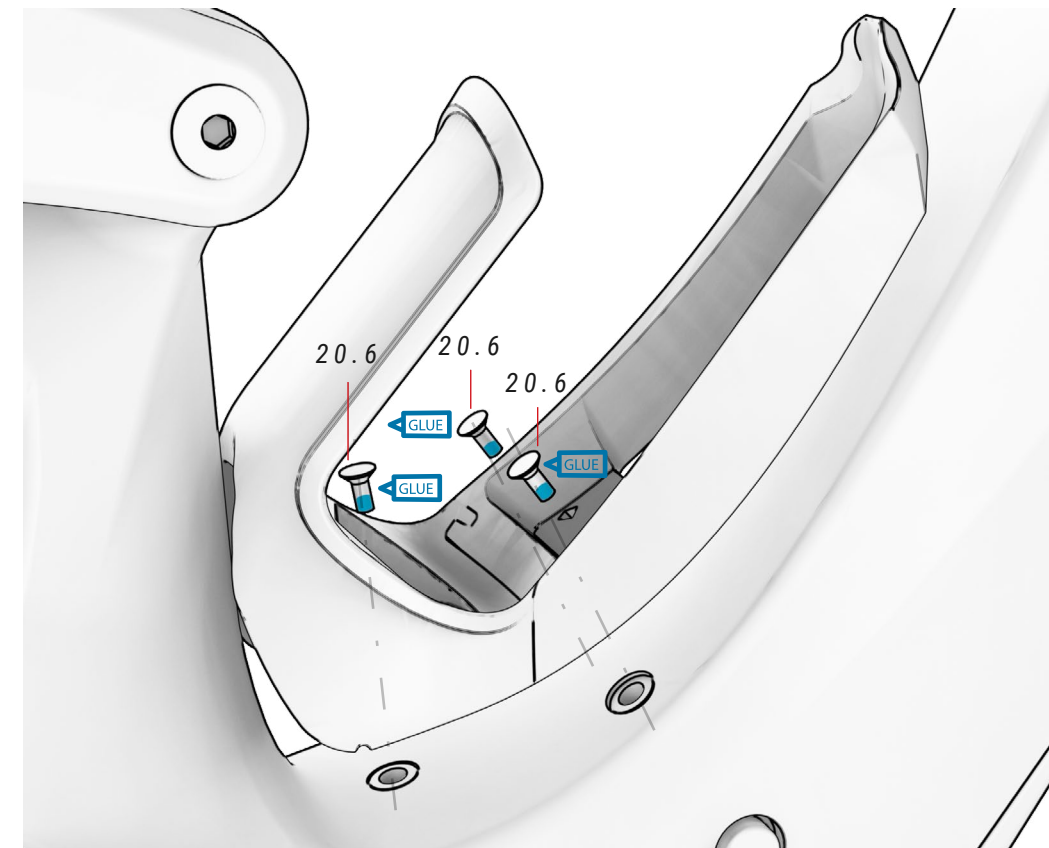

⚠ Excessively long bolts may cause damage to the battery that is not covered by the warranty. Never force the bolts.

### 20 PLASTIC CAP SET

ref.: 381216100

No.	Item	Quantity
20.1	Bolt	2
20.2	Cable guide on the front triangle	2
20.3	Cable guide on the right chainstay	1
20.4	Cable guide on the left chainstay	1
20.5	Battery bracket	1
20.6	Bottle holder bolts M5xP0.8x18 mm	3
20.7	Bolt fastener	1
20.8	Rear brake stay bolt	2

### 21 PROTECTORS

ref.: 393232300

No.	Item	Quantity
21.1	Chainstay protector	1
21.2	Seat stay protector	1

### 22 BOTTLE HOLDER BOLT FASTENER

No.	Item	Quantity
22.1	Bottle holder bolt fastener	3

## CHAIN GUIDE

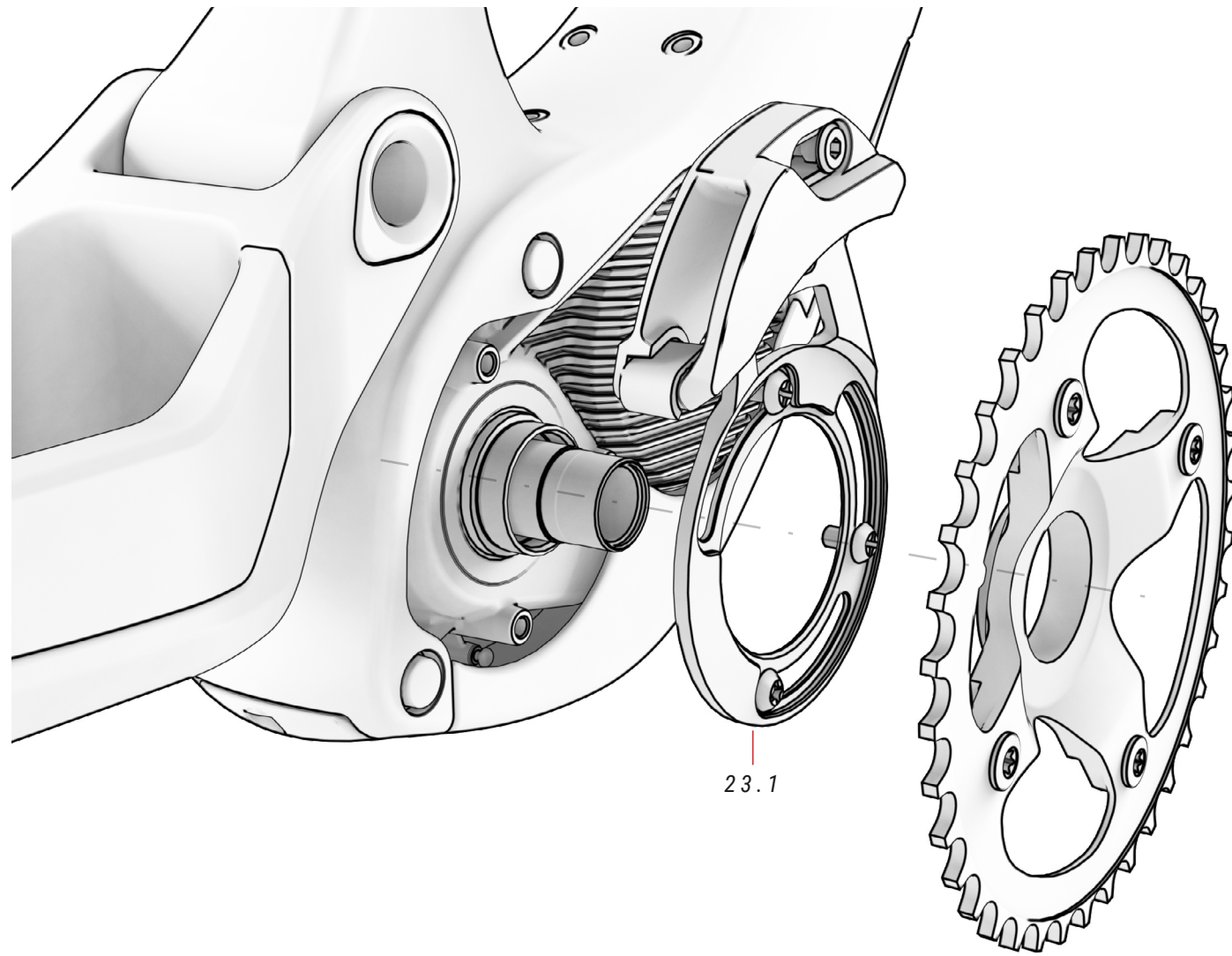

### 23 CHAIN GUIDE

No.	Item	Quantity
23.1	Chain guide	1

## BH-2EXMAG MOTOR CHAINSET

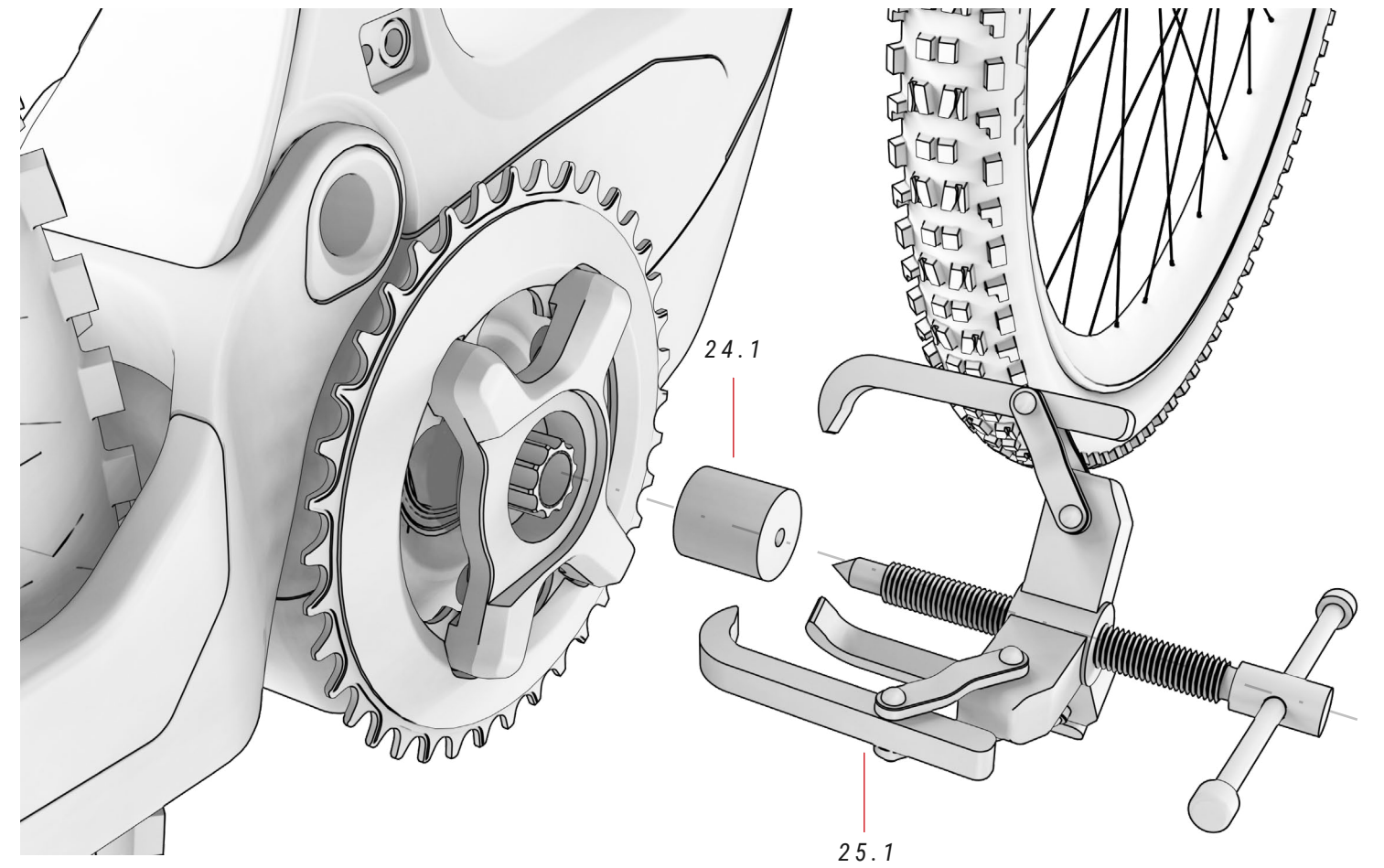

### 24 GROOVED NUT TOOL ref. 387244400

No.	Item	Quantity
24.1	Tool for grooved nut	1

### 25 CHAINSET EXTRACTOR WITH CAP

No.	Item	Quantity
25.1	Chainset extractor with cap	1

## SPEED SENSOR, CABLE GUIDES AND STAY BOLTS USED TO COUPLE THE BRAKES

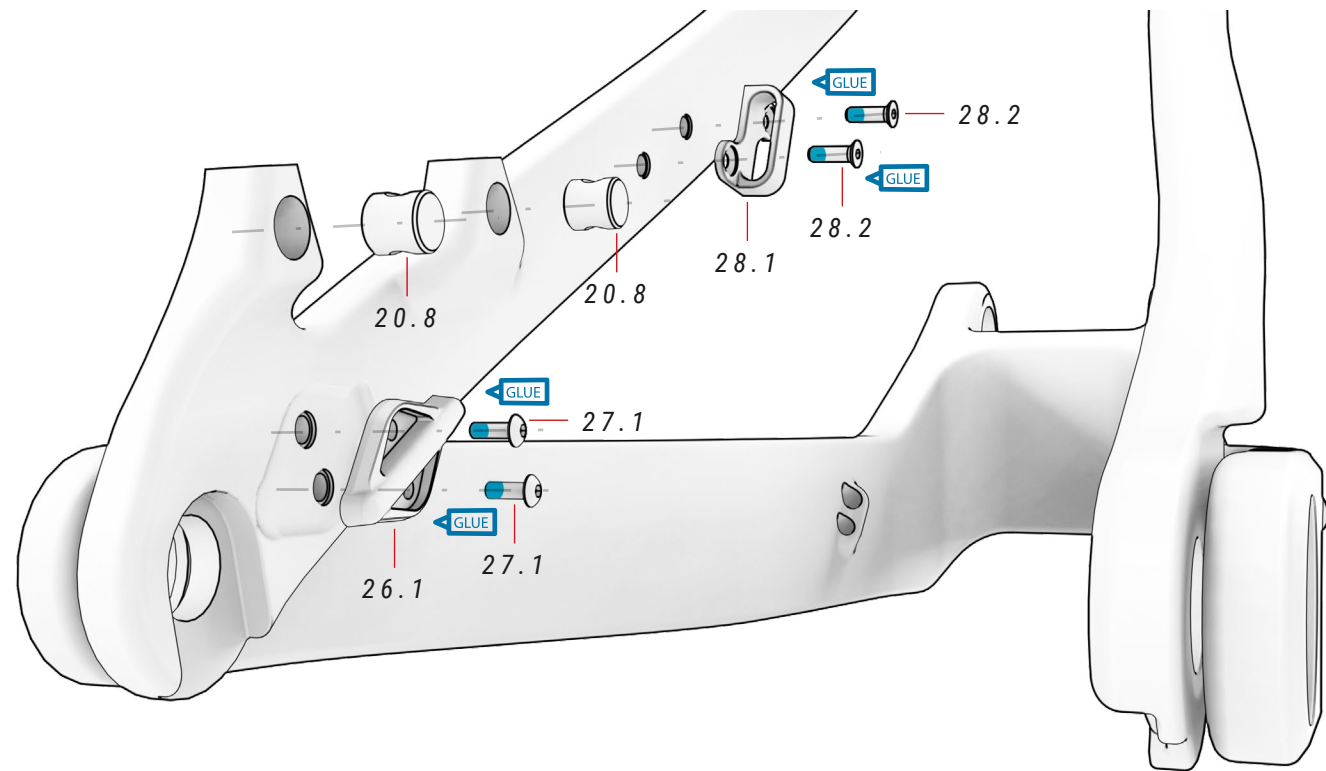

### 26 SPEED SENSOR

No.	Item	Quantity
26.1	Built-in speed sensor	1

### 27 SPEED SENSOR BOLT

No.	Item	Quantity
27.1	Speed sensor bolt	2

### 28 CABLE GUIDES AND BOLTS

No.	Item	Quantity
28.1	Cable guide	1
28.2	Cable guide bolt	2

## MUDGUARD

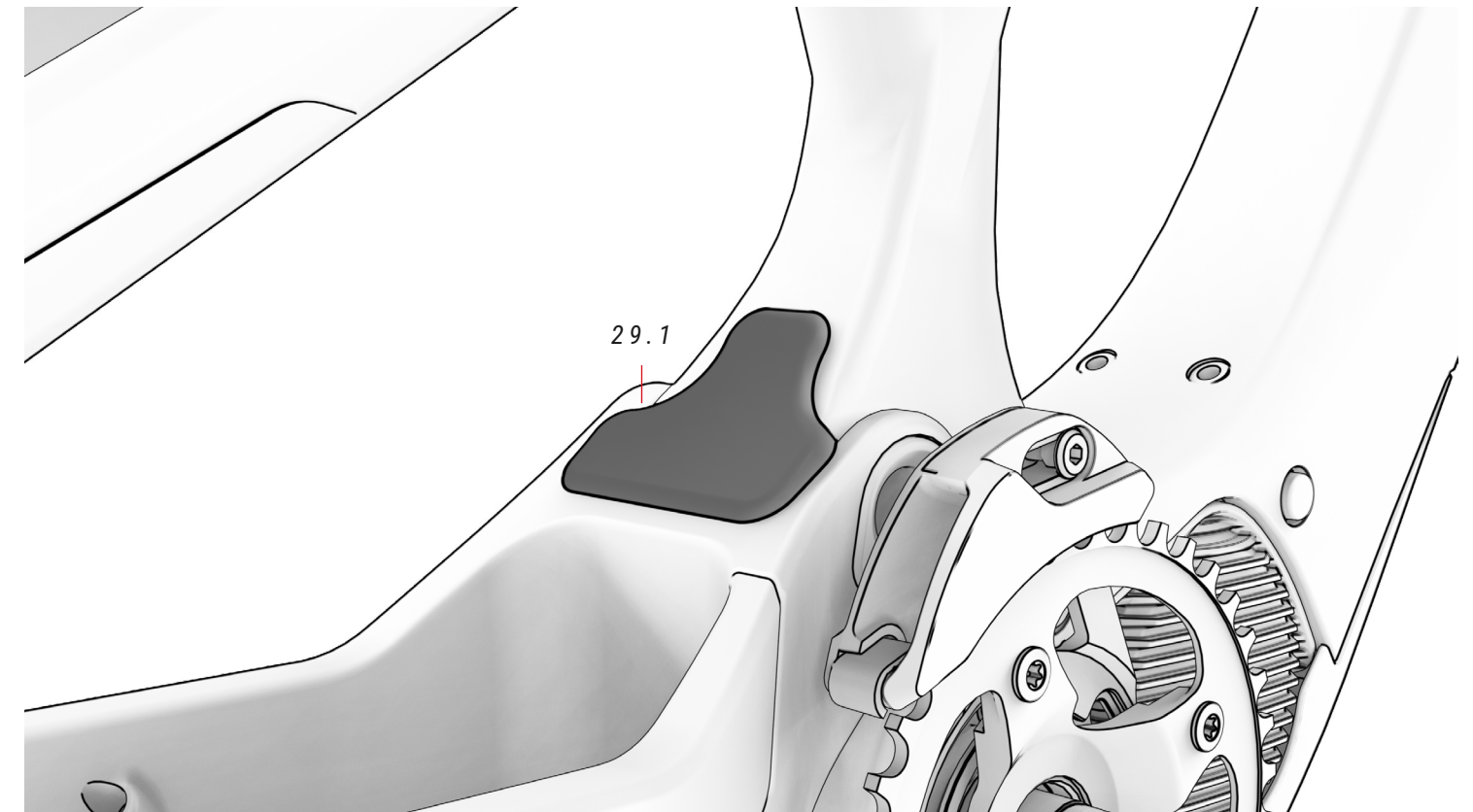

### 29 REAR MUDGUARD

ref.: 386221500

No.	Item	Quantity
29.1	Mudguard	1

## CABLING OF THE MECHANICAL PARTS

The FIT stem allows the mechanical and electrical cables to be wired directly through its front holes, achieving a more aerodynamic, clean and minimalist finish. In addition, the cables are routed from the frame to the chainstays, so these are covered and protected at all times.

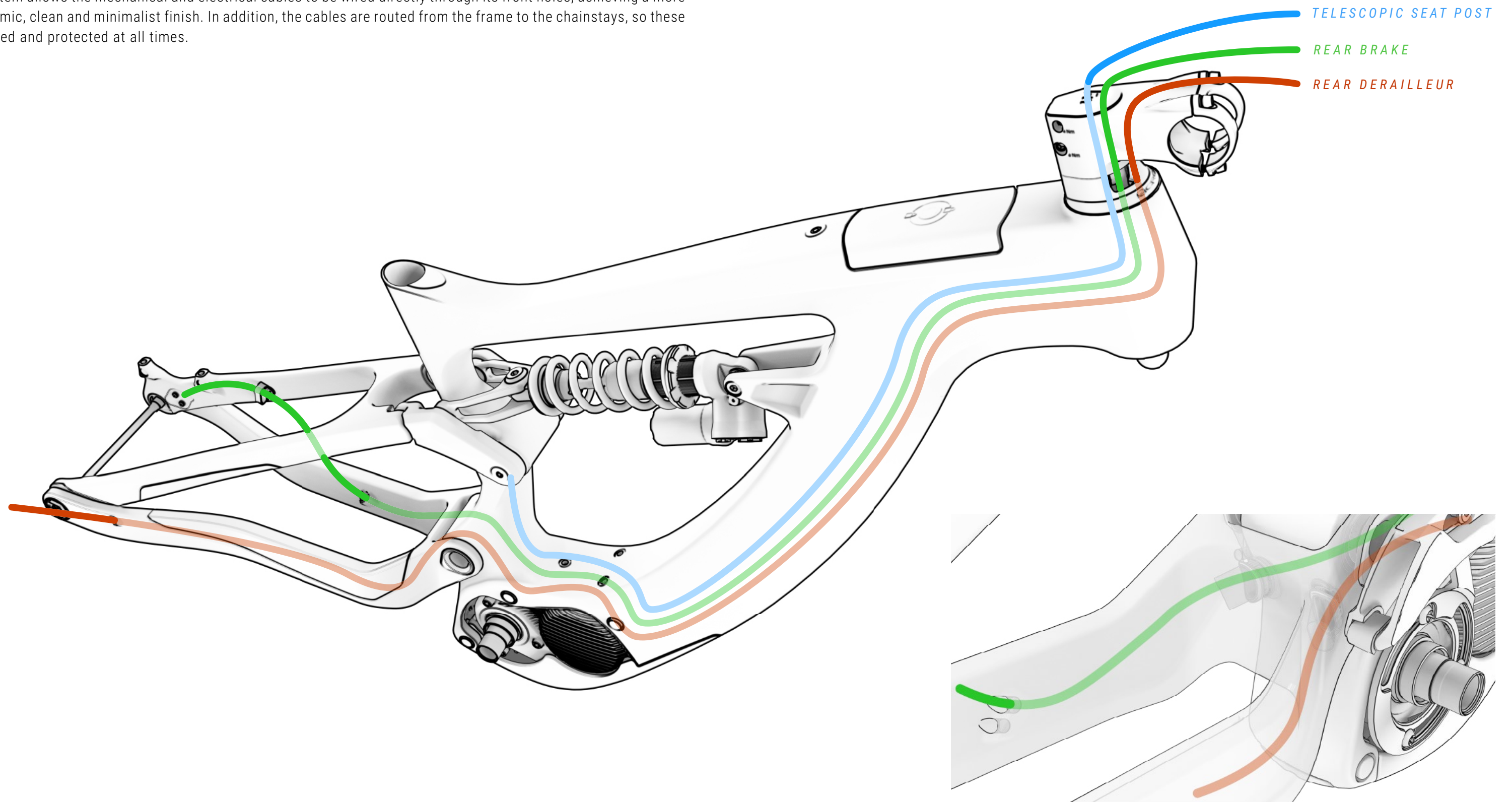

CABLING OF THE ELECTRICAL SYSTEM'S PARTS

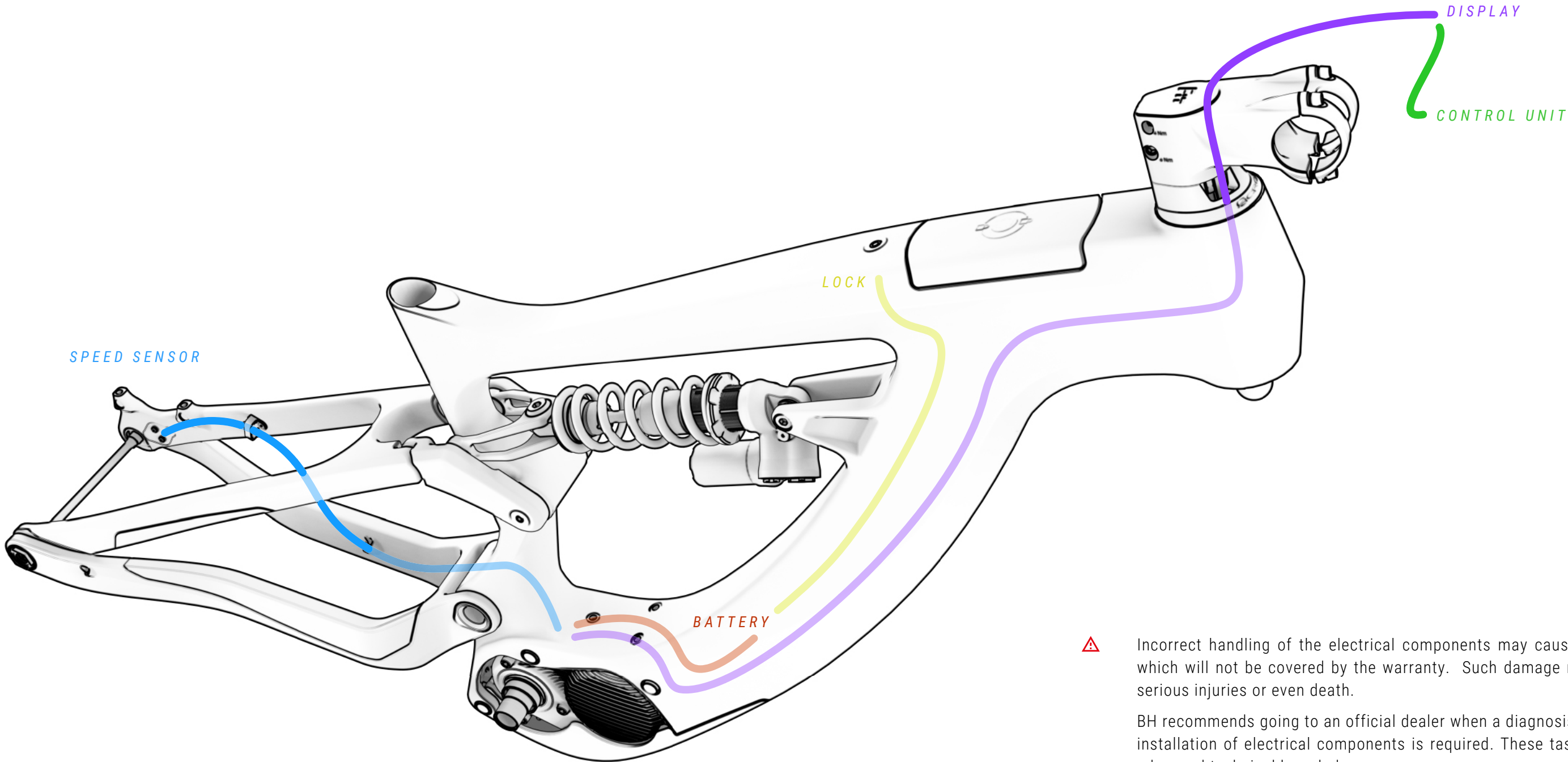

⚠ Incorrect handling of the electrical components may cause damage, which will not be covered by the warranty. Such damage may cause serious injuries or even death.

BH recommends going to an official dealer when a diagnosis, repair or installation of electrical components is required. These tasks require advanced technical knowledge.

# WIRING DIAGRAM OF THE ELECTRICAL SYSTEM'S PARTS

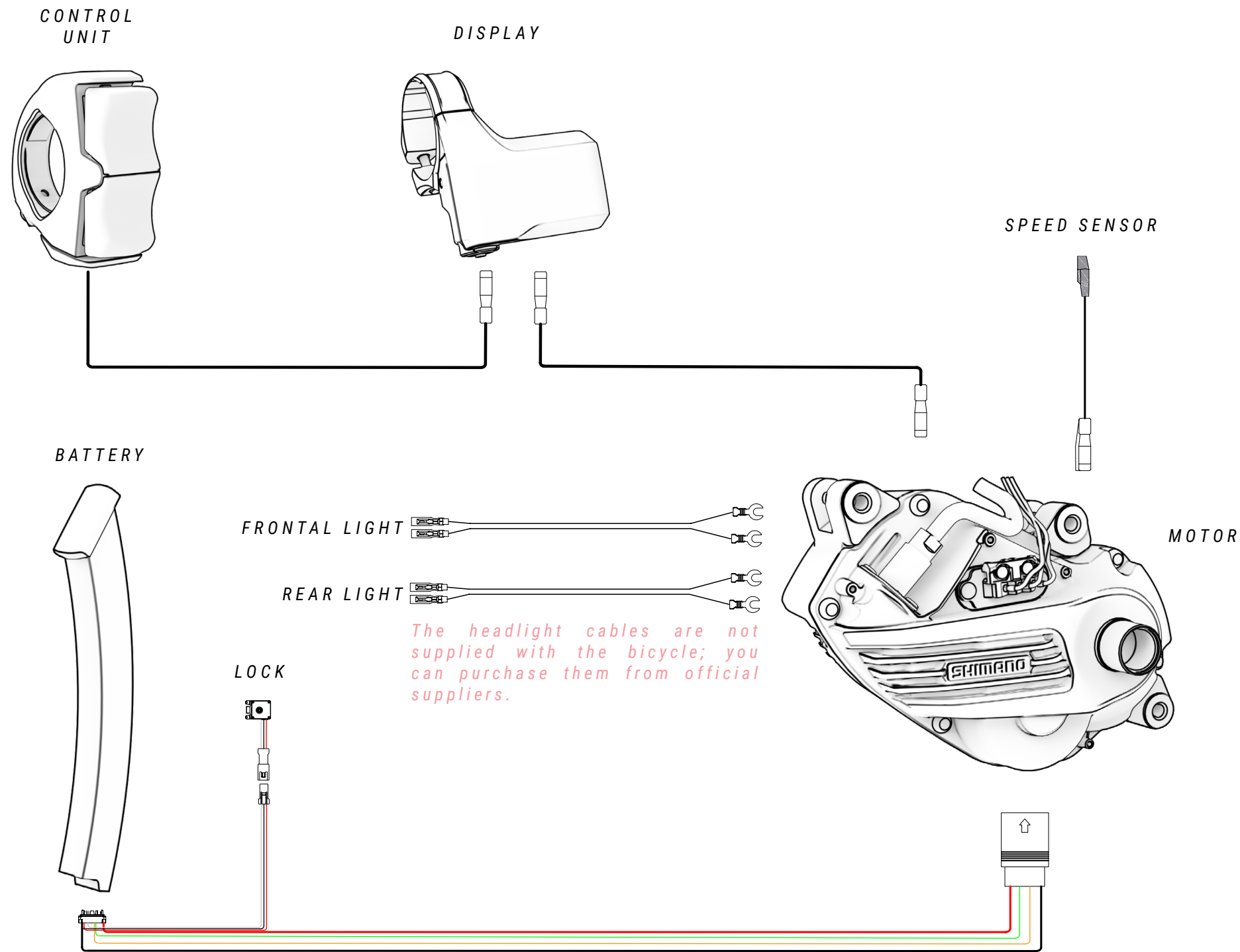

⚠ For accurate and safe installation of Shimano components, please refer to the specific manufacturer's manual:  
<https://si.shimano.com/en/pdfs/dm/EP800/DM-EP800-04-ENG.pdf>

⚠ Incorrect handling of the electrical components may cause damage, which will not be covered by the warranty. Such damage may cause serious injuries or even death.  
 BH recommends going to an official dealer when a diagnosis, repair or installation of electrical components is required. These tasks require advanced technical knowledge.

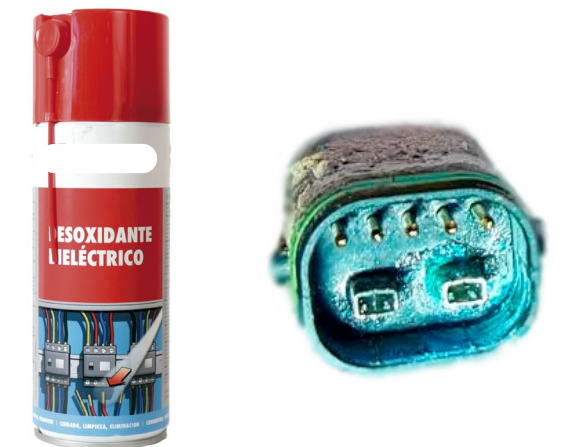

⚠ When electrical connections come into contact with damp spots or are clogged due to external contamination, a chemical reaction occurs, causing a build-up of lead sulphate crystals in the connections. In other words, the copper on the contacts will rust, resulting in conductivity problems.  
 The warranty does not cover damage caused by incorrect maintenance of the bicycle's connections. To prevent rust, simply clean the connections (male and female) at regular intervals, using dielectric deoxidisers like the one shown in the image above.



# 10 DECLARATION OF CONFORMITY

## EU Declaration of Conformity

**The manufacturer:** BH BIKES EUROPE, SL  
c/ Perretagana 10,  
01015 Vitoria, Spain

Hereby declares that the following products:

**Product description:**  Cycles –Electrically power assisted cycles –EPAC Bicycles

**Models designation:**

Atom 27,5, Atom 29, Atom City, Atom City Pro, Atom City Wave, Atom City Wave Pro, Atom Cross, Atom Cross Pro, Atom Diamond Wave Pro, Atom Jet, Atom Jet Pro, Atom Lynx 5.5, Atom Lynx 5.5 Pro, Atom Lynx 8.0, Atom Lynx 8.1, Atom Lynx 8.2 Pro, Atom Pro, Atom Street, Atom Street Pro, Atom Suv Pro.

AtomE City Wave Pro, AtomE Diamond Wave Pro, AtomE Cross Pro, AtomE Jet Pro, AtomE Lynx 8.0, AtomE Lynx 8.2, AtomE Pro, AtomE Suv Pro, AtomE Suv Pro-S, AtomE Suv Pro-SE.

AtomS 27,5 Pro, AtomS 29 Pro, AtomS City Wave Pro, AtomS City Wave Pro-S, AtomS Cross Pro, AtomS Cross Pro-S, AtomS Diamond Pro, AtomS Diamond Wave Pro, AtomS Diamond Wave Pro-S, AtomS Jet Pro, AtomS Jet Pro-S, AtomS Pro, AtomS Pro-S, AtomS Street Pro, AtomS Suv Pro, AtomS Suv Pro-S.

AtomX Carbon Lynx 5.5 Pro, AtomX Carbon Lynx 5.5 Pro-S, AtomX Carbon Lynx 6 Pro, AtomX Carbon Lynx 6 Pro-S, AtomX Carbon Lynx 6 Pro-SE, AtomX Cross Nitro, AtomX Cross Pro, AtomX Cross Pro-S, AtomX Lynx 5.5 Pro, AtomX Lynx 5.5 Pro-L, AtomX Lynx 5.5 Pro-S, AtomX Lynx 6 Pro, AtomX Lynx 6 Pro-S, AtomX Lynx 6 Pro-SE, AtomX Lynx Pro 8.2, AtomX Lynx Pro 8.4, AtomX Lynx Pro 9.0, AtomX Lynx Pro 9.2, AtomX Lynx Pro 9.4, AtomX Lynx Carbon Pro 8.7, AtomX Lynx Carbon Pro 8.8, AtomX Lynx Carbon Pro 9.7, AtomX Lynx Carbon Pro 9.8, AtomX Lynx Carbon Pro 9.9, AtomX Pro, AtomX Pro-S.

Core 29, Core Pro, Core City Wave, Core Cross, Core Gravel X 2.2, Core Gravel X 2.4, Core Gravel X Carbon 2.6, Core Gravel X Carbon 2.7 Pro, Core Jet, Core Pro, Core Race 1.2, Core Race 1.4, Core Race Carbon 1.5, Core Race Carbon 1.6, Core Race Carbon 1.8, Core Race Carbon 1.8 Pro, Core Race Carbon 1.9 Pro, Core Street.

iLynx Race Carbon 7.6 LT, iLynx Race Carbon 7.7 LT, iLynx Race Carbon 7.8 LT Pro, iLynx Race Carbon 7.9 Pro, iLynx Race Carbon 8.0 LT, iLynx Race Carbon 8.2 LT, iLynx Race Carbon 8.4 LT Pro, iLynx Race Carbon 8.6 Pro, iLynx Trail 8.0, iLynx Trail 8.1, iLynx Trail 8.2, iLynx Trail Carbon 8.6, iLynx Trail Carbon 8.7, iLynx Trail Carbon 8.8 Pro, iLynx Trail Carbon 8.9 Pro.

iLynx+ Trail Carbon 8.7, iLynx+ Trail Carbon 8.8, iLynx+ Trail Carbon Pro 8.9, iLynx+ Enduro Carbon 9.7, iLynx+ Enduro Carbon 9.8, iLynx+ Enduro Carbon Pro 9.9.

iAerolight 1.7, iAerolight 1.8, iAerolight Pro 1.9.

Xtep Carbon Lynx 5.5 Pro, Xtep Carbon Lynx 5.5 Pro-S, Xtep Carbon Lynx 6 Pro, Xtep Carbon Lynx 6 Pro-S, Xtep Carbon Lynx 6 Pro-SE, Xtep Cross Pro, Xtep Lynx 5.5 Pro, Xtep Lynx 5.5 Pro-L, Xtep Lynx 5.5 Pro-S, Xtep Lynx 5.5 Pro-SE, Xtep Lynx Carbon 8.7 Pro, Xtep Lynx Carbon 8.8 Pro, Xtep Lynx Carbon 9.7 Pro, Xtep Lynx Carbon 9.8 Pro, Xtep Lynx Carbon 9.9 Pro, Xtep Pro-S, Xtep Lynx Carbon Pro 0.7, Xtep Lynx Carbon Pro 0.8, Xtep Lynx Carbon Pro 0.9.

**Year of manufacture:** 2022 and 2023

Comply with all of the relevant requirements of the Machinery Directive (2006/42/EC).

Comply with Low Voltage Directive (LVD) 2014/35/EU

Comply with all of the relevant requirements of RD 339/2014, de 9 de Mayo.

Furthermore, the machine complies with all of the requirements of the Electromagnetic Compatibility Directive 2014/30/EU.

The production control is assured by our Quality Management System, which fulfills the requirements of the standard ISO 9001

The following harmonized standards have been applied:

DIN EN 15194 Cycles – Electrically power assisted cycles – EPAC bicycles;

DIN ISO 4210-1/2/3/4/5/6/7/8/9 Safety requirements for bicycles

Technical documentation filed at:

BH BIKES EUROPE, SL  
c/ Perretagana 10,  
01015 Vitoria, Spain



José María Chapinal  
Quality Manager  
BH BIKES EUROPE, SL

Rev.16

17/05/2022

Page 1 of 1

# 11 HELP AND ADDITIONAL RESOURCES

BH offers different channels to resolve your queries. In addition, you can join our global cyclist community on our social media.

## TECHNICAL RESOURCES

You can find all of the resources you need to fine-tune your bicycle on the BH Bikes website. Click on the link below to access the user manuals, apps, warranties, display update files and videos that explain different operations:

<https://www.bhbikes.com/manuals>

You can also check out our step-by-step tutorials to learn how to maintain and fine-tune your bicycle on our specialised Youtube channel:

<https://www.youtube.com/user/ServicioTecnicoBH>

## CONTACT US

Our authorised dealers have the necessary knowledge and resources to help you with anything you need in relation to your bicycle. Don't hesitate to contact your nearest store. You can find it by clicking on the link below:

[https://www.bhbikes.com/es\\_INT/tiendas/buscador-de-tiendas](https://www.bhbikes.com/es_INT/tiendas/buscador-de-tiendas)

To contact us directly:

Tel.: + 34 945 13 52 02

[info@bhbikes.com](mailto:info@bhbikes.com)

P.I. Jundiz- Perretagana 10, 01015 Vitoria, Alava (Spain)

## SOCIAL MEDIA

Join our global cyclist community. Discover the BH experiences of other cyclists and share yours.



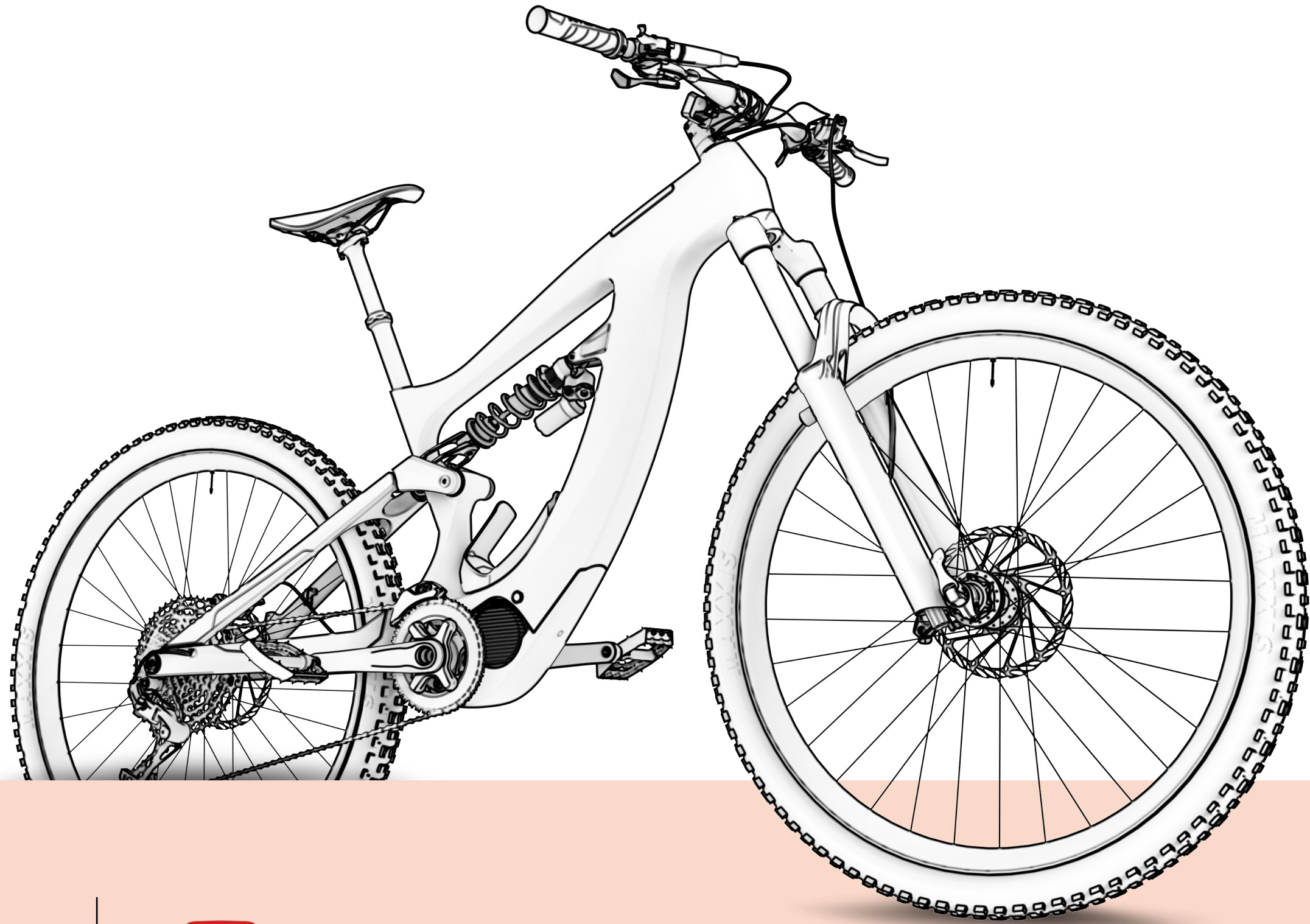

[www.bhbikes.com](http://www.bhbikes.com)



**BH**