

TekDoc

USER MANUAL  
2022



**/** GENERAL BIKE USER MANUAL

v0.0

**BH**

# CONTENTS

<b>01 INTRODUCTION</b> .....	<b>3</b>
SYMBOLS .....	3
<b>02 SAFETY STANDARDS</b> .....	<b>4</b>
<b>03 CONDITIONS FOR USE</b> .....	<b>4</b>
<b>04 PARTS OF A BICYCLE</b> .....	<b>5</b>
MOUNTAIN BIKE COMPONENTS .....	5
PARTS OF A ROAD BIKE .....	6
<b>05 SETTINGS AND SAFETY CHECKS</b> .....	<b>7</b>
TIGHTENING TORQUES .....	7
LUBRICATING AND FASTENING THE PARTS .....	7
BICYCLE SIZE .....	7
MOUNTING THE PEDALS .....	7
LEFT PEDAL .....	7
SADDLE HEIGHT AND POSITION .....	7
RIGHT PEDAL .....	7
ADJUSTING THE HEADSET .....	8
STANDARD SEAT POST CLAMP .....	8
EXAMPLE OF A HEADSET .....	8
ADJUSTING THE STEM, HANDLEBARS AND LEVERS .....	8
WHEEL MOUNTING SYSTEM .....	9
BRAKE SYSTEM .....	10
ADJUSTING THE SUSPENSION .....	11
TYRE ADJUSTMENT .....	11
<b>06 MAINTENANCE</b> .....	<b>12</b>
INSPECT THE BICYCLE BEFORE USE .....	12
KEEP THE BICYCLE CLEAN .....	12
KEEP THE TRANSMISSION LUBRICATED AT ALL TIMES .....	12
PART MAINTENANCE .....	12
SPARE PARTS .....	13
AFTER A FALL, BLOW OR IMPACT .....	14
<b>07 WARNINGS ON USE</b> .....	<b>14</b>
MAXIMUM TYRE SIZE .....	14
MINIMUM AND MAXIMUM INSERTION LENGTH OF THE SEAT POST .....	14
MAXIMUM FORK LENGTH (AXLE-TO-CROWN) .....	14
MAXIMUM NUMBER OF STEERING SPACERS .....	14
POSITION OF THE SPINDLE INSIDE THE FORK TUBE .....	14
INTENDED USE .....	14
<b>08 WARNINGS ON USE OF THE ELECTRICAL ASSISTANCE SYSTEM</b> .....	<b>15</b>

CARE AND INSTRUCTIONS FOR USE OF THE ELECTRICAL COMPONENTS AND BATTERIES .....	15
RECOMMENDATIONS TO MAXIMISE THE BATTERY LIFE .....	15
WARNINGS ON THE USE OF BATTERIES .....	15
UNSUITABLE CHARGING AND DISCHARGING ENVIRONMENTS AND SOLUTIONS.....	15
RECYCLING .....	15
MOTOR .....	15

<b>09 BH WARRANTY</b> .....	<b>16</b>
LIFETIME FRAME WARRANTY .....	16
EXTENDED WARRANTY OF UP TO 5 YEARS ON BH MOTORS .....	17
EXTENDED WARRANTY FOR BH BATTERIES .....	17
REGISTERING EXTENDED WARRANTIES .....	18
WARRANTY OF PARTS OF THE ELECTRICAL ASSISTANCE SYSTEM .....	18
SUBMITTING A WARRANTY CLAIM .....	18
CONDITIONS THAT MAY VOID THE WARRANTY OF ELECTRICAL COMPONENTS .....	18
<b>10 DECLARATION OF CONFORMITY</b> .....	<b>19</b>

# 01 INTRODUCTION

This user manual contains important information for proper use and maintenance of the bicycle. In particular, the document contains general information applicable to all bicycles of the BH family. Please read the entire manual carefully.

For more detailed information, you can consult the specific user manuals for each bike model at the following address:

<https://www.bhbikes.com/manuals>

Keep in mind that the manuals on the BH BIKES website are updated on a regular basis. Make sure you have downloaded the latest version from the website. You can check the version on the front page.

This same link also gives access to download apps, warranties, files to update the displays and explanatory videos for different operations.

You can also check out our step-by-step tutorials to learn how to maintain and fine-tune your bicycle on our specialised Youtube channel:

<https://www.youtube.com/user/ServicioTecnicoBH>

Our authorised dealers have the necessary knowledge and resources to help you with anything you need in relation to your bicycle. Don't hesitate to contact your nearest store. You can find it by clicking on the link below:

[https://www.bhbikes.com/es\\_INT/tiendas/buscador-de-tiendas](https://www.bhbikes.com/es_INT/tiendas/buscador-de-tiendas)

To contact us directly:

Tel: + 34 945 13 52 02

[info@bhbikes.com](mailto:info@bhbikes.com)

P.I. Jundiz- Perretagana 10, 01015 Vitoria, Alava (Spain)

We also invite you to visit our social networks so that you can ask your doubts within our large global community of cyclists.



Despite all the resources available for setting up your bike, you should be aware that cycling is a potentially dangerous activity. Apart from the set-up, there are other external factors that can increase the probability of suffering an accident. Therefore, from BH we invite you to take every possible precaution by always riding with a helmet and suitable protective goggles.

You should also always take into account the regulations that apply in the country in which you are riding your bicycle.

## SYMBOLS

This document contains different icons that refer to use, maintenance and assembly warnings. Carefully read the meaning of each one to prevent improper handling or hazardous situations that may result in serious personal injuries or fatal accidents.

### SAFETY



**DANGER:** refers to a hazardous situation that, if not avoided, will lead to serious injuries or even a fatal accident.



**WARNING:** refers to a hazardous situation that, if not avoided, could lead to serious injuries or even a fatal accident.



**ATTENTION:** refers to a hazardous situation that, if not avoided, could cause minor or moderate injuries.



**RISK OF ELECTRIC SHOCK:** refers to a hazardous situation that, if not avoided, could cause serious injuries due to electric shock or even death.



**RISK OF SHORT CIRCUIT:** refers to a hazardous situation that, if not avoided, could cause short circuits in the electrical components. Short circuits may cause damage to the electrical components and fire.

© Reprinting, translation and reproduction or other economic use, for example in electronic media, including abstracts, is not permitted without the prior written consent of the author and publisher..

## 02 SAFETY STANDARDS

There is a label on the bicycle frame that indicates the safety standards met by the bicycle. One of the following standards will appear on the label, depending on the type of bicycle:

### ISO 8098: KIDS' BICYCLES

This international standard specifies the testing methods, safety requirements and performance features associated with the design, assembly and tests on kids' bicycles and their sub-assemblies. It also provides the guidelines associated with use and maintenance.

This standard applies to bicycles with a maximum saddle height of more than 425 mm and less than 635 mm, which are propelled by a force transmitted by the rear wheel. This standard does not apply to special bicycles designed to perform stunts by experts (for example, BMX bikes).

### ISO 4210: LEISURE, MOUNTAIN, ROAD AND YOUNG ADULT BICYCLES

This international standard specifies the testing methods, safety requirements and performance features associated with the design, assembly and tests on bicycles and their sub-assemblies, with a saddle height as indicated in the table below. This standard does not apply to special types of bicycles, such as delivery bikes, special bicycles designed for stunts carried out by experts, tandem bikes, BMX bikes (EN 16054) and bicycles designed and equipped for extreme use in competitions.

### EN 15194: BICYCLES WITH PEDAL ASSISTANCE SYSTEMS (BPAS)

This standard applies to bicycles with pedal assistance systems with a maximum continuous rated power of 0.25 kW, which is progressively reduced as the speed approaches 25 km/h, or before this speed if the cyclist stops pedalling.

This standard specifies the testing methods, safety requirements and performance features associated with the design, assembly and tests carried out on bicycles with pedal assistance systems, which have a battery voltage of up to 48 VDC and a battery charger with a 230 V input. It also establishes the requirements and testing methods for the motor power management systems and electrical circuits, including the charging system.

### MAXIMUM WEIGHT ALLOWED ACCORDING TO THE TYPE OF BICYCLE

	BIKE + CYCLIST + LUGGAGE	LUGGAGE
Stroller	155 kg (341,7 lb)	Observe the instructions in the luggage rack booklet.
Kids (14",16",18" / 20", 24")	65kg (143,31 lb) / 95kg (209,4 lb)	
Mountain	155 kg (341,7 lb)	
Racing	155 kg (341,7 lb)	
Foldable	145 kg (319,6 lb)	
Electric assistance	165 kg (363,7 lb)	

## 03 CONDITIONS FOR USE

Each range of bikes has been designed to be used under certain conditions of use. Failure to follow these conditions of use may lead to accidents and damage not covered by the warranty. You can see the conditions under which each bike should be used in each model's specific manual.

The different categories of bikes and the conditions of use applicable to each of them are detailed below:

### CITY

City bikes are only designed for use in cities. They are made to ride on bike lanes, paved roads or even on unpaved roads that are in a good condition with an even surface.

### ROAD

Road bikes are intended for use on tarmacked roads. Moreover, their wheels must be kept in contact with the road surface at all times.

### SPORT



Sport bikes are suitable for mixed use between mountains, trails and roads.

### TRAIL

Trail bikes can be used under several conditions including difficult trails, unpaved paths and difficult terrains that are unsurfaced and require technical skills. The maximum jumping and/or drop height is 61 cm (24").

### ENDURO

Enduro bikes are made for riding on extremely difficult terrains, with jumps greater than 61 cm (24").

-  In the case of bicycles designed for children, the conditions for use must be supervised by an adult at all times.
-  Keep in mind that, even if the bicycle is used according to its intended use, all cyclists must wear suitable protection equipment, such as a helmet and protective glasses. In addition, cyclists must carry out the main safety checks before each outing.
-  The greater the fatigue to which the components are exposed, the shorter the service life. Some factors, such as the weight borne by the bicycle, usage frequency or duration of the trip, have a direct impact on the bicycle's service life.

## 04 PARTS OF A BICYCLE

This section indicates the main parts of road, mountain, general-purpose and triathlon bikes.

### MOUNTAIN BIKE COMPONENTS

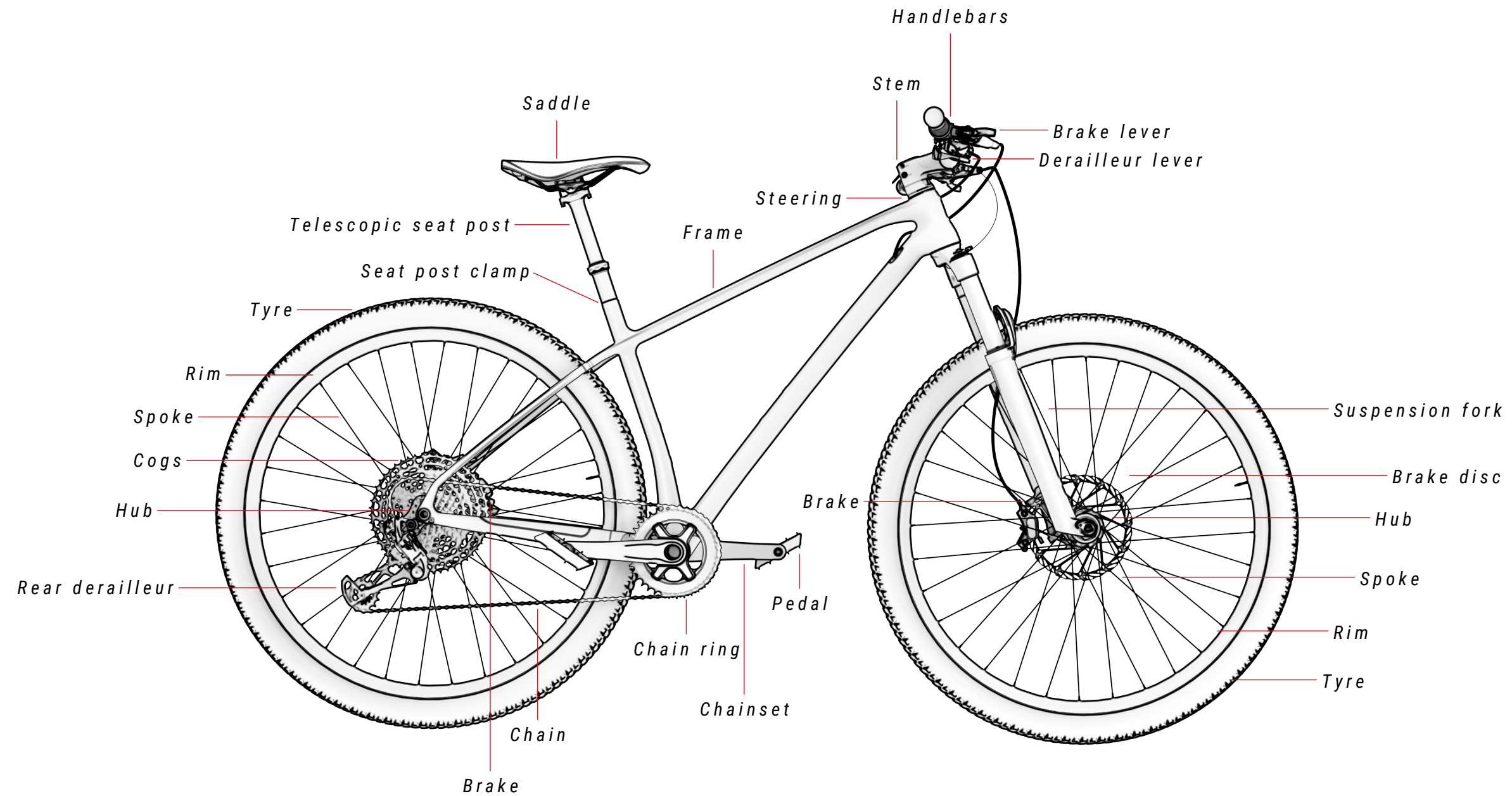

PARTS OF A ROAD BIKE

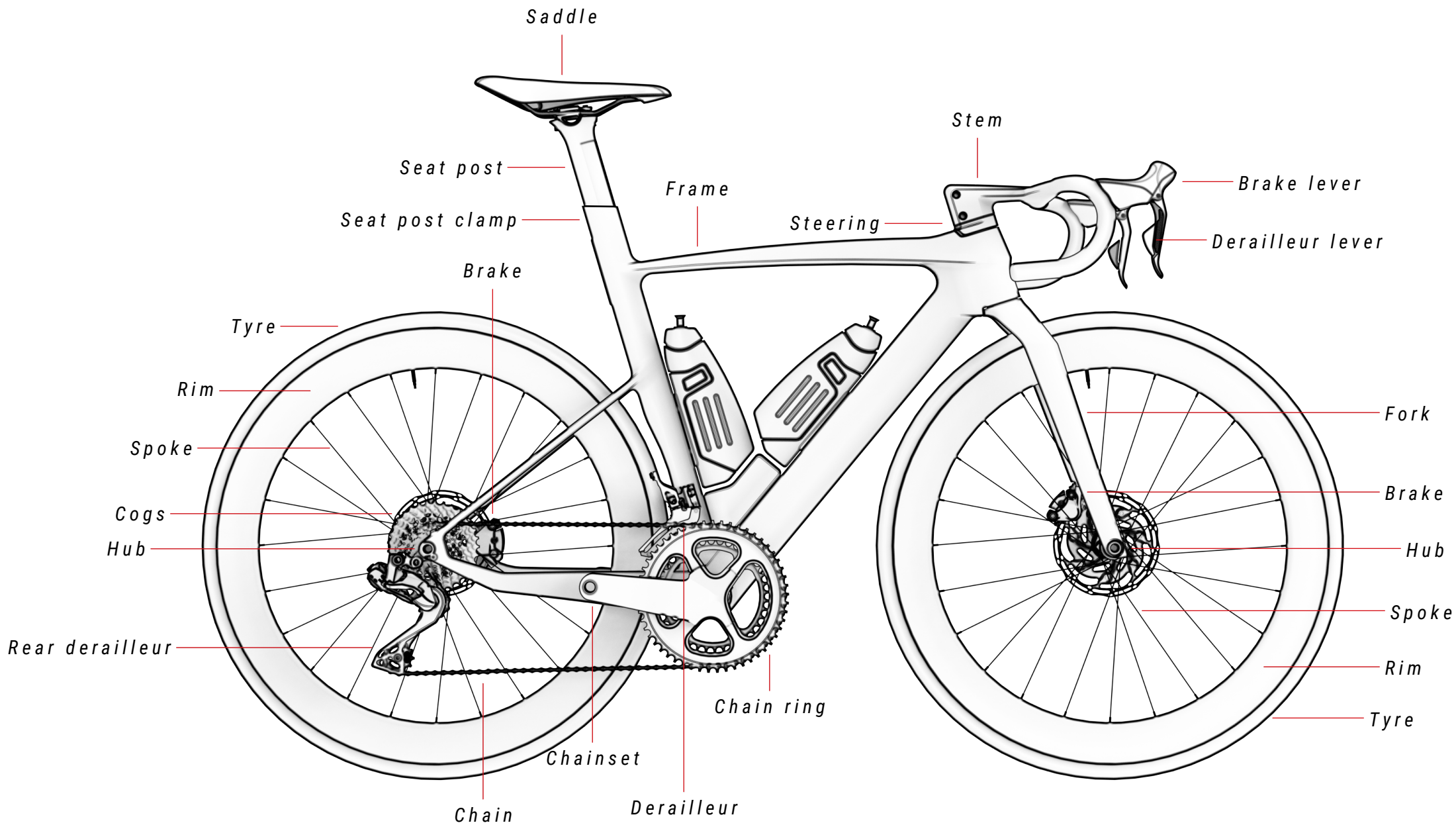

## 05 SETTINGS AND SAFETY CHECKS

This section explains the adjustments and main safety checks required to minimise the risk of accident. With safety checks such as the height of the saddle, it may be sufficient to do this on the first trip. However, the points described in this section must be taken into account before each outing.

### TIGHTENING TORQUES

The tightening torques are very important when mounting the different parts of the bicycle. Failing to apply the correct tightening torque may cause an accident. Moreover, the fault may not be covered by warranty. Therefore, all parts must indicate the tightening torque of the bolts. Likewise, an incorrect tightening torque may cause premature wear and result in an accident.

The specific manuals of each bicycle indicate the correct tightening torques for BH parts. Please refer to the corresponding assembly manuals for the tightening torques for third-party parts. If you have any queries or do not have the necessary knowledge to check the corresponding tightening torques, please contact your nearest official BH dealer.

### LUBRICATING AND FASTENING THE PARTS

It is essential to keep parts such as the chain or bearings lubricated, to prevent premature wear that could lead to an accident. Likewise, incorrect lubrication may affect the bicycle's performance and could cause accidents.

Inspect the state of lubrication before each outing. Wash it after lubrication and always lubricate it after it is washed. Pay special attention to the chain and suspensions and inspect the derailleurs, stem, pedals and bearings indicated in the specific manuals of each bicycle at least once a year.

Moreover, it is important to use special adhesion systems to prevent bolts from releasing and causing damage or accidents. Thread lock can help maintain the correct tightening torque.

The specific manuals of each bicycle model indicate the correct lubrication and fastening settings for BH parts. Please refer to the corresponding assembly manuals for the lubrication and fastening requirements for third-party parts. If you have any queries or do not have the necessary knowledge to lubricate or fasten the parts, please contact your nearest official BH dealer.

### BICYCLE SIZE

Please check the size and dimensions of the bicycle before riding it to make sure that it suits your body size. A bad riding position may have a negative impact on performance and result in accidents. BH's website features a tool that you can use to calculate the bicycle size that best suits you according to your height. Likewise, the specific manuals of each bicycle and the catalogues include information with all of the frame dimensions.

## MOUNTING THE PEDALS

The pedals must be mounted properly to prevent them from coming loose and causing an accident. Therefore, pedals must be screwed in tightly onto the chainsets. The right pedal is screwed in clockwise, as shown in the images below. Make sure that the pedal marked with the letter "R" is mounted on the right side and the pedal marked with the letter "L" is mounted on the left side.

The left pedal must be screwed in counterclockwise. It is screwed in like this to make sure that it does not come loose when pedalling. Attempting to screw it in clockwise may break the thread, rendering it inoperative.

LEFT PEDAL

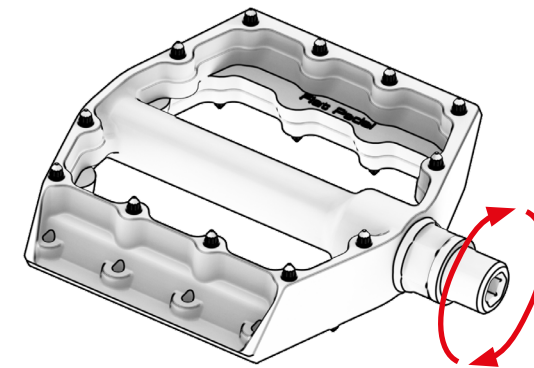

RIGHT PEDAL

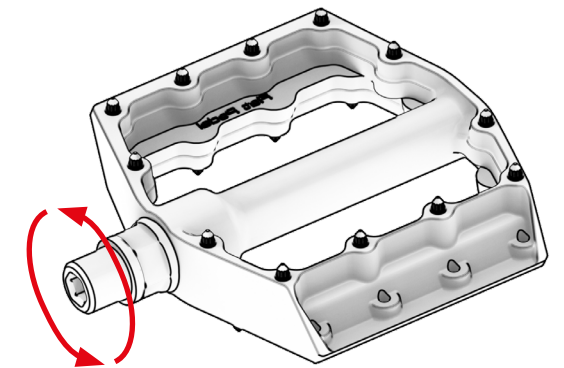

### SADDLE HEIGHT AND POSITION

The height and position of the saddle will have a direct impact on the cyclist's performance. An incorrect height and position may cause injuries in the short or long-term. The optimum height is where the cyclist is sitting on the saddle and the heel is resting on the pedal. With the leg straight and the pedal as far as possible from the position of the saddle. Check whether you need to balance your hip when you pedal with a lot of power. If this is the case, the saddle should be lowered to correct this.

The saddle must be parallel to the ground. This horizontal position is required to ensure good ergonomics and achieve optimum pedalling efficiency.

Keep in mind that the frames, seat posts and saddles have minimum and maximum insertion dimensions that must be respected at all times. If a seat post is not inserted properly into a frame, this will generate a level of fatigue for which the frame has not been designed, and which may cause the frame to break, voiding the warranty. To prevent this, always inspect the seat post and frame specifications and restrictions in the manufacturers' manuals. The specific manuals of each BH bicycle provide the restrictions for each frame. If you need to adapt the riding position in order to achieve the ergonomic position described at the start of this section, and in so doing fail to observe the minimum or maximum restrictions, you may have chosen an incorrect bicycle size.

Loosen the clamp on the saddle seat post to release the seat post before adjusting the saddle height. You will find a standard clamp or one built into the frame, depending on the bicycle model. In any case, respect the bolt tightening torque specs to prevent the saddle from moving if it is too loose or from damaging the frame and seat post if it is too tight. Check the tightening torques recommended by the manufacturers. BH indicates the necessary tightening torques of each bicycle model in its specific manuals.

### STANDARD SEAT POST CLAMP

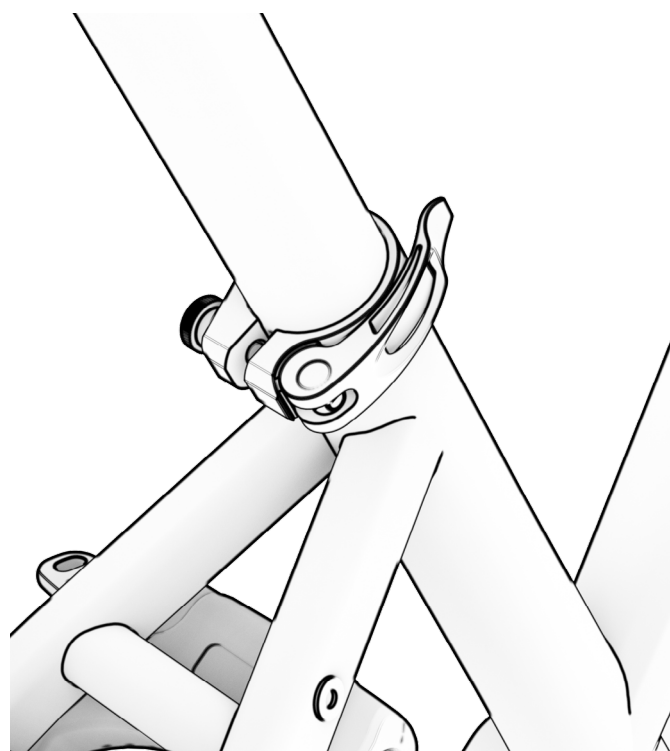

## ADJUSTING THE HEADSET

The bicycle's headset is designed to make the handlebars and fork turn with no resistance and smoothly. The example in the image below shows that there are a series of bearings and washers to allow this. Gaps may appear between the parts if these are not compressed correctly using a spindle or they are not maintained as needed. You can check for gaps by moving the handlebars from side to side, listening for abnormal noises or clicks. If there are gaps, do not use the bicycle and take it to your nearest official BH dealer.

In the case of bicycles with a built-in BH FIT stem, the spindle is replaced with a set of washers, built into the stem. Refer to your bicycle's manual if the bicycle features a BH FIT stem to learn more about how it must be mounted correctly.

 Riding a bicycle with gaps on its parts may result in a serious accident.

## EXAMPLE OF A HEADSET

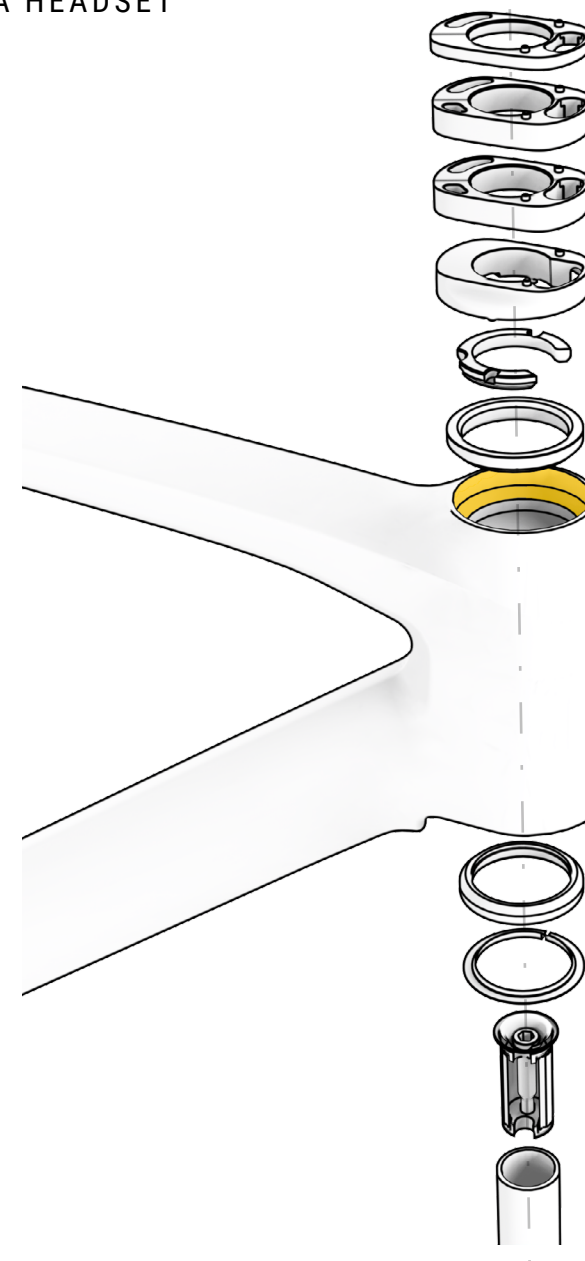

## ADJUSTING THE STEM, HANDLEBARS AND LEVERS

The handlebars are used to guide the entire bicycle. Therefore, in terms of safety, this is one of the most important elements. To prevent unwanted maladjustments during the trip that may cause accidents, the parts must be mounted with the tightening torque required by the manufacturers. The stem on the fork and handlebars. An excessively high tightening torque may cause damage that is not covered by the warranty. Likewise, it is important to place the derailleur and brake levers so that, in the normal pedalling position, they are within reach of the fingers.

Refer to your bicycle's manual if the bicycle features a BH FIT stem to learn more about how it must be mounted correctly.

With regards to the handlebars, it must be checked that they are perpendicular to the bicycle when looking from above, as shown in the image below.

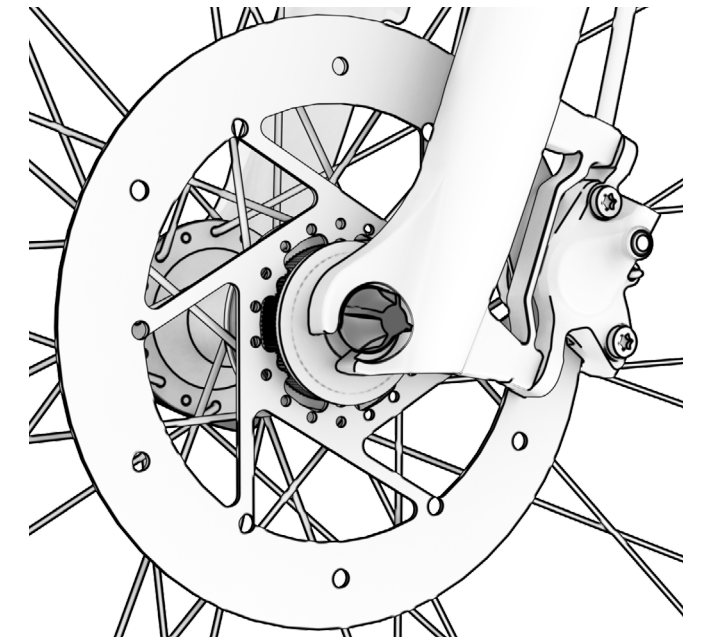
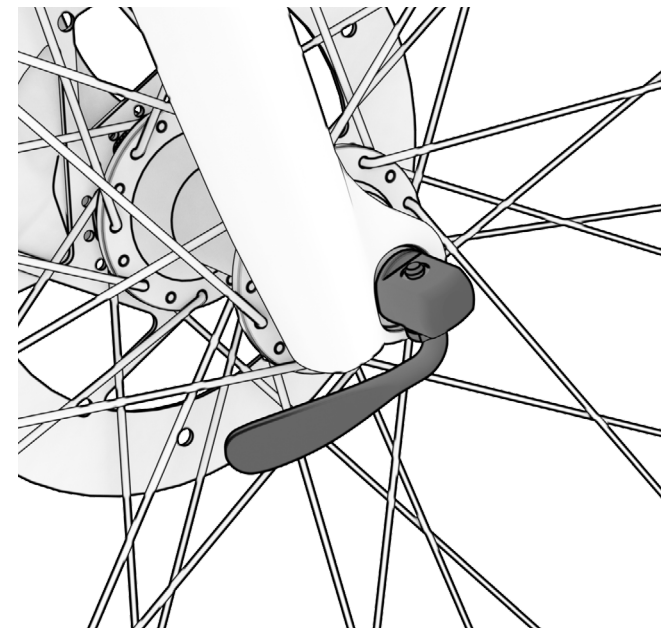
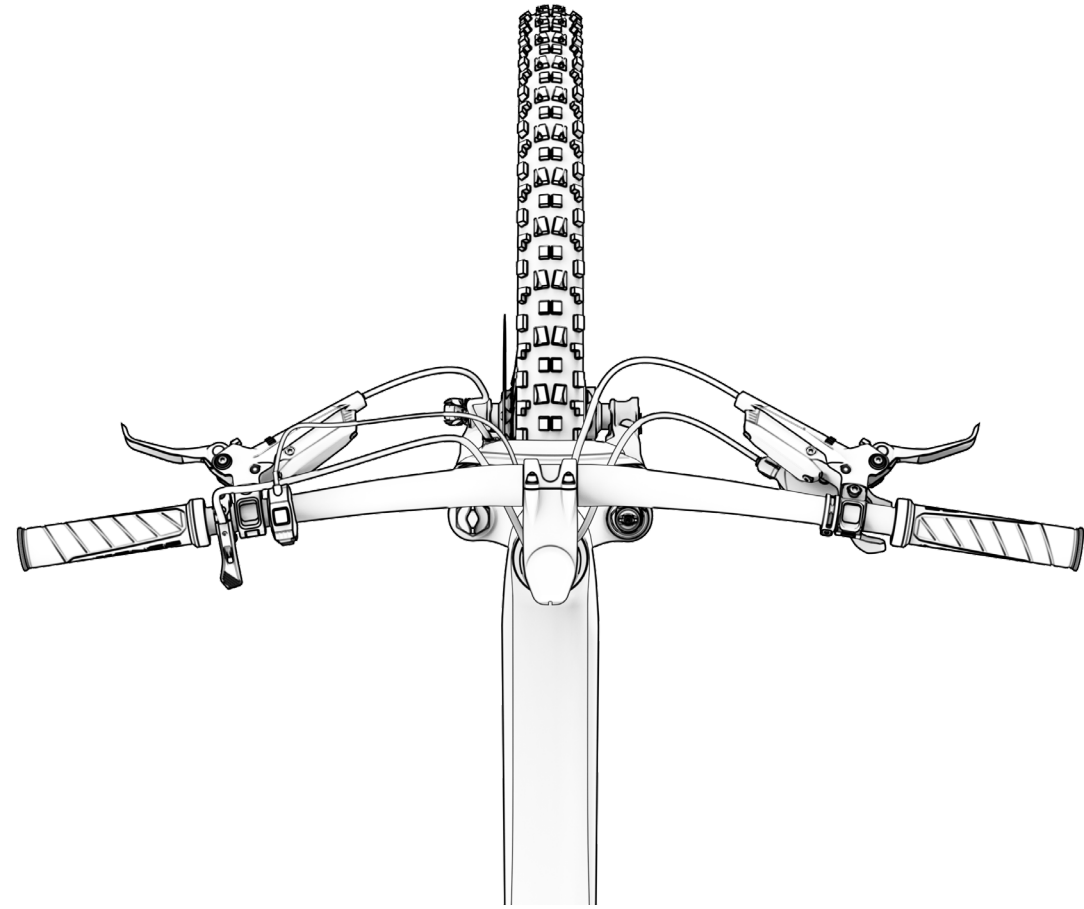

## WHEEL MOUNTING SYSTEM

The wheels are fastened with quick-release mechanisms. In other cases, such as axles with a Split Pivot suspension system, these are fastened with a thru-axle, nuts and bolts. The image below shows the lever with a quick-release mechanism first and then the nut.

Always check that the wheels are secured onto the fork and frame before each outing. Lift the bicycle and turn the wheel, which must rotate freely and smoothly when you stop turning it by hand. In addition, check and make sure that there are no gaps on the wheel. In other words, make sure that the wheel does not rock from left to right, as shown in the last image on the page. If there are gaps, take the bicycle to your nearest official BH dealer before riding it.

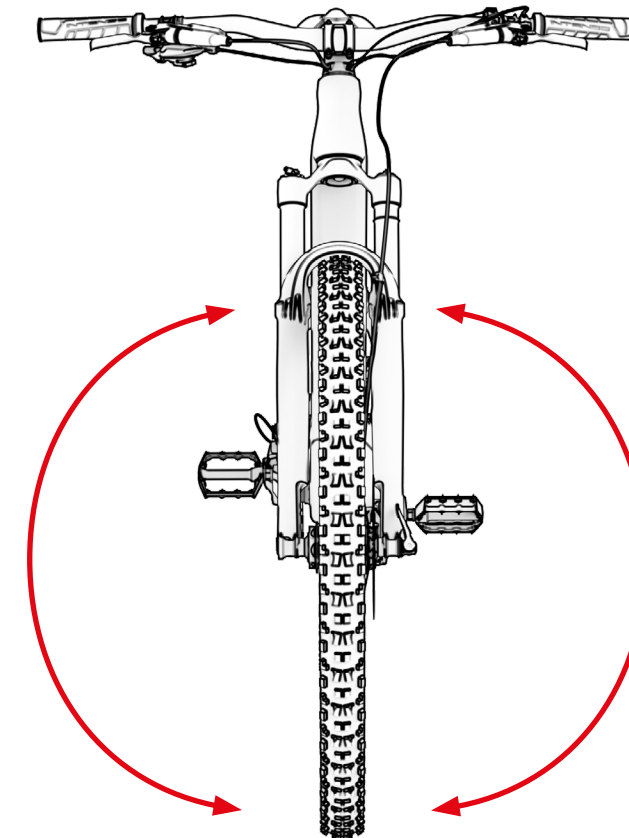

## BRAKE SYSTEM

Brakes are another of the bicycle's main safety systems. Before each outing, make sure that the brakes are working properly. While standing, turn the wheel and press the brake lever down fully to check that the wheel stops instantly. Perform this process with both wheels.

Even if the wheels stop correctly, check that when you fully press the lever down, it is at a distance of at least 25 mm from the handlebars. The images below show an example of levers on mountain and road bikes.

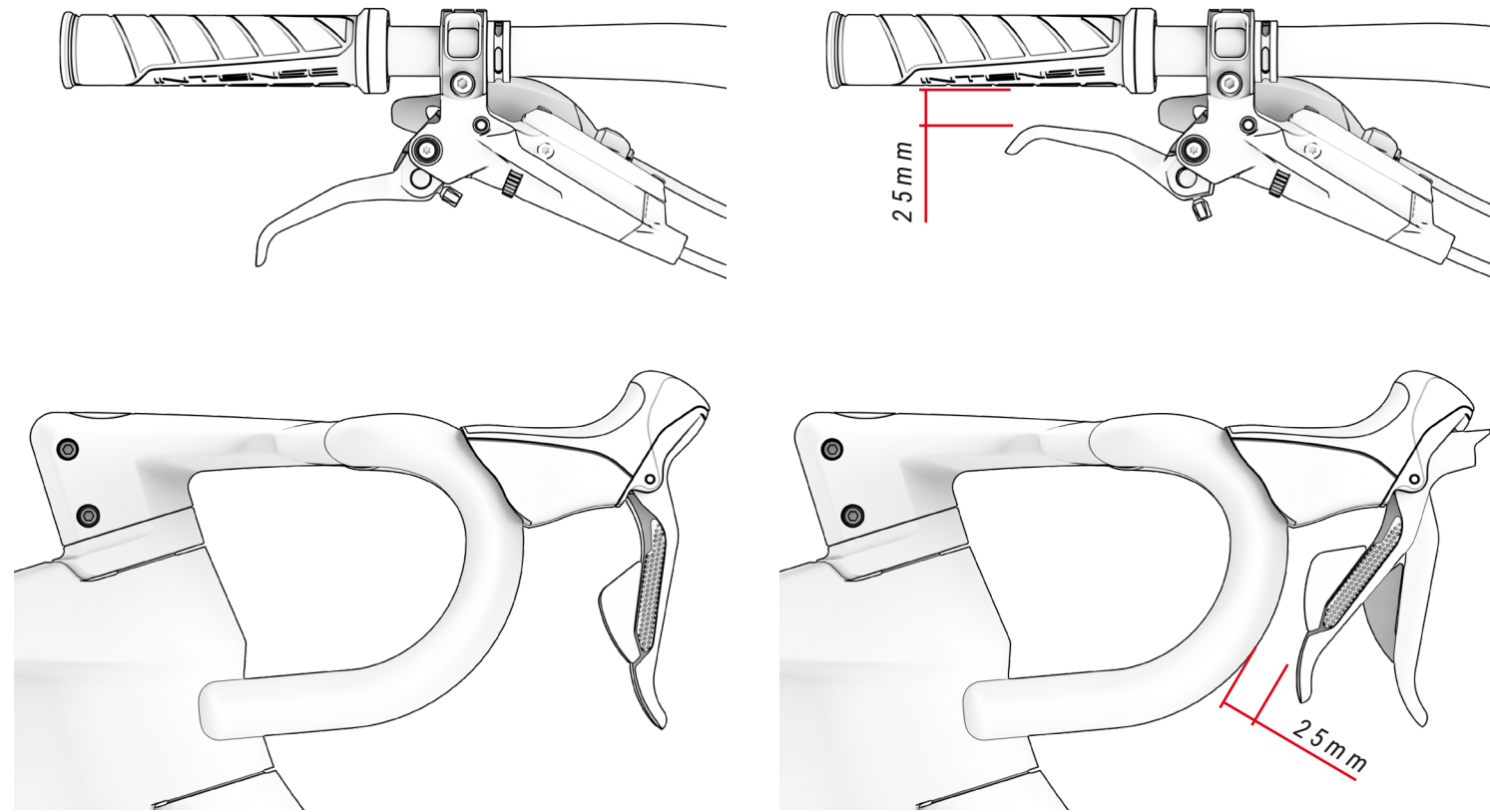

Moreover, check the condition of the cables or the hydraulic system before each outing, depending on the type of brake system mounted. In the case of brakes with cables, these must be secured using the tightening torques established by the part manufacturers. In addition, visually inspect them to make sure that there are no defects or damage.

In the case of hydraulic brakes, make sure that there are no leaks on the levers or across the covers. The brake fluid must be bled, according to the part manufacturers' instructions.

BH recommends you take the bicycle to an official dealer for all comprehensive brake maintenance tasks required.

With regards to mounting the brakes, these must be secured to ensure that when pushing forwards and backwards, as shown in the image below, they do not move.

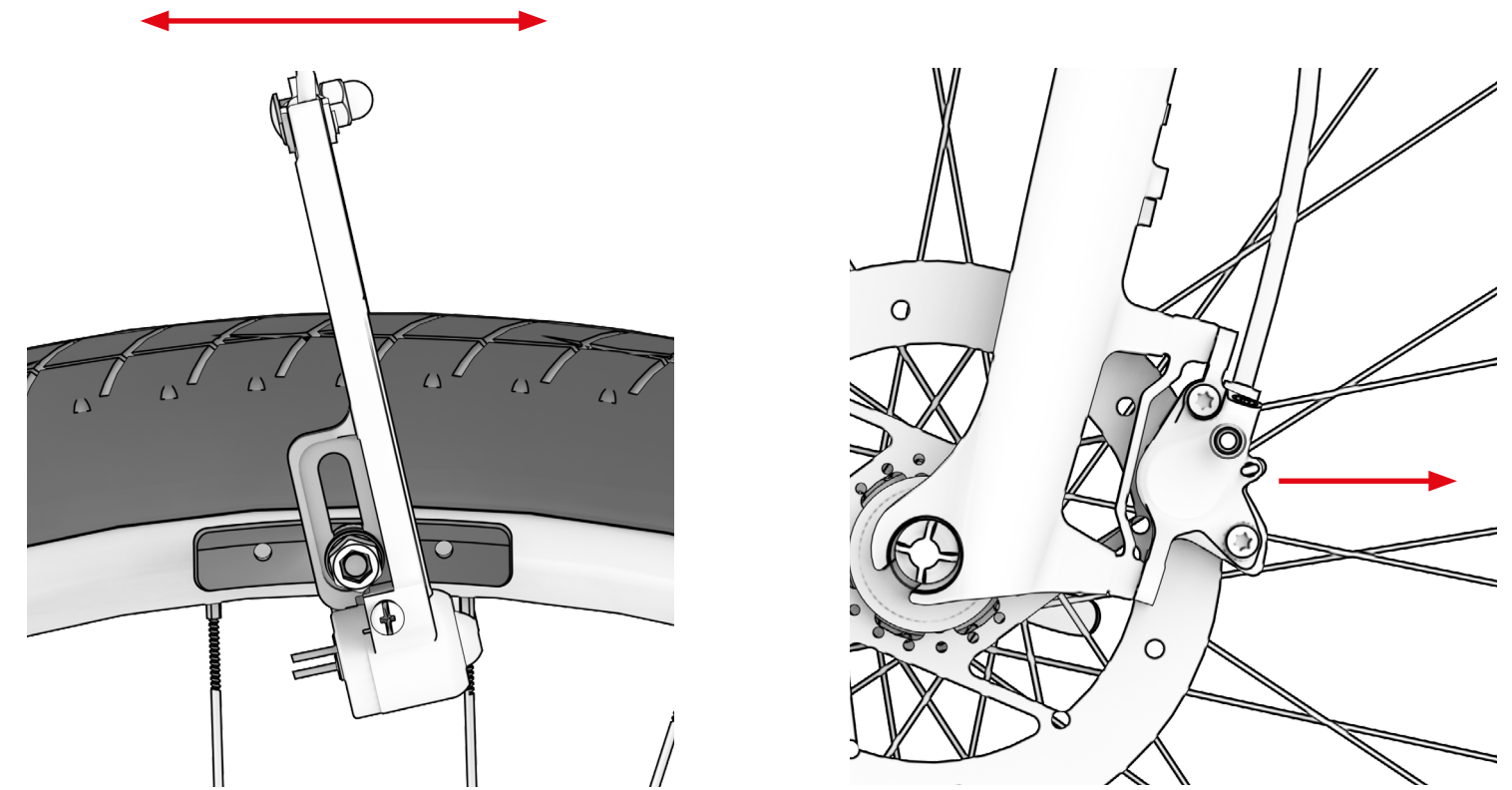

In the case of brakes with brake pads, check they are in the correct position. The images below show that the brake pads must be at a distance of 1 to 2 mm from the tyre. The brake pads must never touch the tyre. In addition, the brake pads must be mounted so they are at a slight angle in the wheel's direction of rotation. To optimise the braking performance and reduce noises.

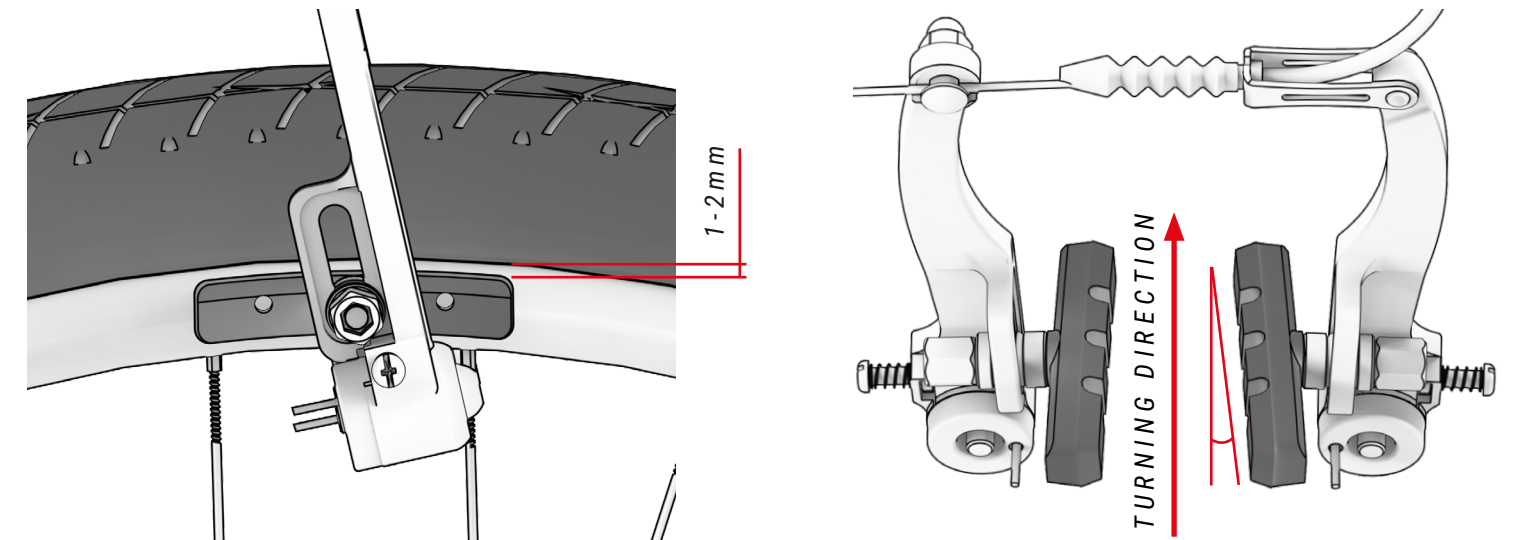

The brake pads and disc brakes are prone to wear and must be replaced according to the manufacturer's specifications. As in the case of the brake pads, the brake discs are also prone to wear and must be inspected for signs of wear, bending or any other anomaly before each trip.

In the event of wear, any anomalies or you are unsure, please contact an official BH dealer.

- ⚠ Do not pour oil, grease or aerosols on the discs or brakes, since these could contaminate the brake pads and make them less effective during braking. Contaminating the brake pads may cause fatal accidents. Never use the bicycle if the brake pads have been contaminated.

## ADJUSTING THE SUSPENSION

The suspension absorbs uneven spots on the riding surface. There are two types of suspension: front and rear. Both must be lubricated at regular intervals and adjusted according to the cyclist's weight and the type of surface on which the bicycle will be used.

Keep in mind that the suspension fork contracts slightly when the cyclist sits on the bicycle, so there is negative travel (sag). This adjustment requires knowledge and use of specific tools. Please contact your nearest dealer to have your suspension adjusted properly. Refer to the manufacturers' manuals to check the specific sag of each suspension.

There must be no strange noises or clicking sounds when moving the suspension while stopped and the movement must be smooth. Please contact your nearest official BH dealer if you detect any anomaly. Refer to the specific manuals of each bicycle to check the suspension assembly process.

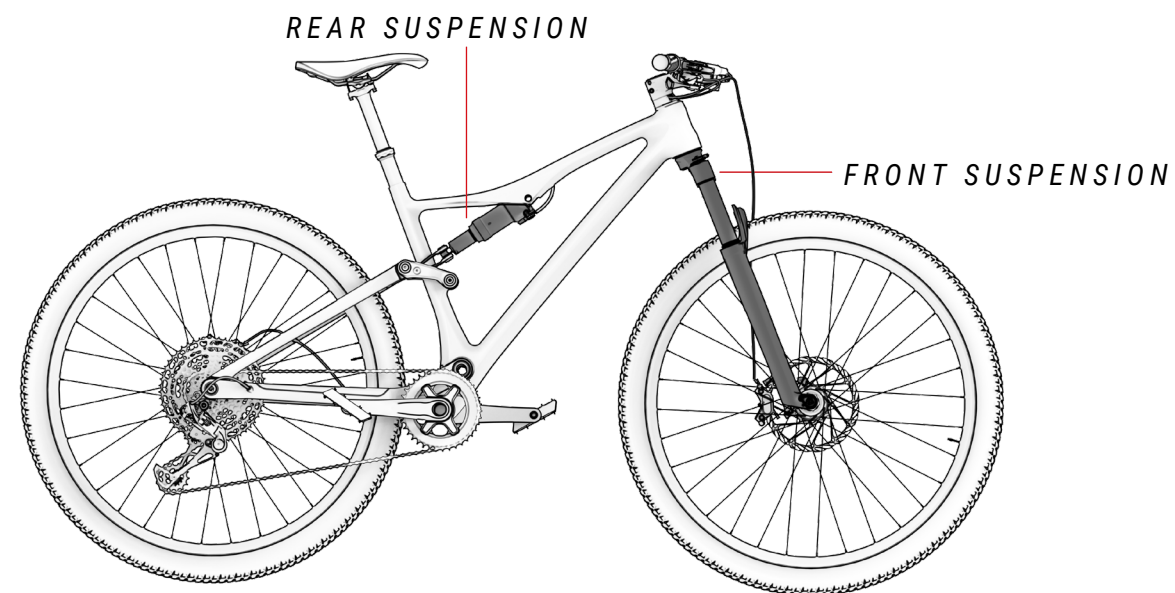

- ⚠ All BH mountain bikes have been solely designed for use with the suspension fork mounted as standard or a similar one. Mounting double-plate forks or other forks of a different length is not allowed. Failure to observe these requirements will void the warranty and may cause serious injuries or damage to your BH bicycle.

## TYRE ADJUSTMENT

Tyres are prone to wear and must be replaced when the maximum degree of wear indicated by the manufacturer is reached. This is the point of contact between the bicycle and the ground, so it is essential to mount tyres according to the surfaces on which the bicycle will be used.

Another key point for the safety of the cyclist is tyre pressure. They must have the pressure indicated by the manufacturer. This is usually marked on the outside of the tyre.

- ⚠ Tyres with a high atmospheric pressure or worn tyres may cause the wheel to have less adherence. Likewise, an excessively low pressure may cause loss of adherence and cause a serious accident. If the manufacturer's requirements are not observed, the damage will not be covered by the warranty.

## 06 MAINTENANCE

Keep in mind that this user manual contains important information for proper use and maintenance of the bicycle in general. For more details and to make sure that your bicycle is set up perfectly, please refer to the specific user manual of each bicycle at:

<https://www.bhbikes.com/manuals>

### INSPECT THE BICYCLE BEFORE USE

Bicycles are inspected several times throughout the manufacturing process and then at the BH workshop during the final check. As the bicycle's operation may be affected during transport or third parties may have modified the bicycle before its sale, the following must be checked before each trip:

- **FRAME:** no cracks, damage or strange noises.
- **CHAIN:** it must be lubricated and the transmission system must not make any strange noises.
- **BRAKES:** the brakes must be working properly. When stopped, press the brake lever with enough strength and check that it does not touch the handlebars.
- **TYRES:** the pressure must be correct and there must be no cuts on the tread or on the sides. Also check that the wear level does not exceed the maximum recommended level.
- **WHEELS:** the wheels must rotate freely in order to check how they rotate. Also check the space between the brake lining and the rim, as well as the space between the frame and tyre.
- **STEERING:** the steering must turn smoothly and with no strange noises.
- **SWINGARM ROTATION POINTS:** when weight is exerted on the bicycle, the suspension must work as expected and with no strange noises. If it is not working properly or there is play between the moving parts, this might mean that the tightening torques are incorrect or that the bearings are worn.
- **BEARINGS:** the bearings must work properly and with no strange noises. The bearings are subject to wear and must be replaced to prevent damage to the components on which they are installed.
- **ELECTRICAL SYSTEM:** if the bicycle features an electrical system, check that it is functioning properly by ensuring that the electrical assistance mode is running and that all parts are functioning properly (motor, display, change of assistance mode and speed sensor). If there is no electrical assistance, check that all connections are correct and show no signs of damage.

 Do not ride your bicycle if it does not meet any of these points! A faulty bicycle may cause serious accidents! If you are unsure or have any queries, please contact your nearest BH workshop!

 Check the tightening torques to make sure that they are as described in the recommendations in the user manuals. Failure to observe these recommendations may result in accidents and even death.

 The effect of the ground and the forces exerted on the wheel subject the bicycle to a lot of stress. The different parts will be subject to fatigue and wear because of these dynamic loads. Check the bicycle at regular intervals to look for signs of wear, scratches, bent parts, wear on the finish or the formation of cracks. Parts may fail suddenly after their service life has expired. Take your bicycle to an authorised BH workshop regularly to have these parts replaced if needed.

### KEEP THE BICYCLE CLEAN

We recommend you follow these basic prevention measures to make sure that the bicycle is in perfect working order. Failure to observe these recommendations may lead to premature wear or even breakages in specific areas, such as gaskets or moving parts.

- Clean the dust and mud with a damp sponge and a gentle and neutral cleaning product.
- Plastic parts must only be washed with soapy water.
- Tyres can be washed with a sponge or brush and soapy water.
- After cleaning the bicycle, dry it by rubbing it firmly with a smooth cloth.
- After each cleaning, lubricate the transmission elements.

 Dirt may cause damage that can result in accidents or even death.

 Never use pressure washers or steam cleaners.

### KEEP THE TRANSMISSION LUBRICATED AT ALL TIMES

After washing the bicycle, the chain transmission's lubrication may have also been washed off. Inspect and lubricate the chain's links, if needed. Excess lubrication may attract more dirt, causing premature wear and incorrect functioning of the system.

 Never use pressure washers or steam cleaners.

### PART MAINTENANCE

The bicycle requires regular maintenance and a minimum number of regular inspections. The frequency of the maintenance operations depends on the type of vehicle (leisure, road or mountain bike), as well as the frequency and conditions of use.

## PART MAINTENANCE CALENDAR

Part	Action required	Before each outing	Monthly	Annually
Lighting	Functional check.			
Tyres	Pressure check.			
	Inspect the height of the profile and sides.			
Brakes (on the rim)	Check the lever travel, lining strength and rim position.			
	Brake test when stopped.			
	Clean the brake pads.			
Brake cables	Visual inspection.			
Brakes (disc brakes)	Change the brake fluid (DOT fluid).			
Suspension fork	Check the bolts and the corresponding tightening torque.			
	Change the oil and lubricate the elastomer.			
Saddle seat post with suspension	Maintenance.			
	Play check.			
Rims on rim brakes	Inspection and replacement, if needed, of the wall linings.	At the latest after the second part of the brake lining.		
Bottom bracket axle	Check the play.			
	Re-lubrication.			
Chain	Check and lubrication.			
	Check and replacement.	After 800 km.		
Chainsets	Check and tightening.			
Wheels / Spokes	Check wheel spin and spoke tension.			
Headset	Inspection of the headset.			
	Re-lubrication.			
Metal surfaces	Maintenance.	At least once every six months.		
Hubs	Bearing inspection.			
	Re-lubrication.			
Pedals	Bearing inspection.			
	Lubrication, cleaning the anchoring mechanism.			

Part	Action required	Before each outing	Monthly	Annually
Saddle seat post / Stem	Inspection of the fastening screws.			
Rear derailleur / Derailleur	Cleaning, lubrication.			
Quick-release mechanism / Thru-axle	Efficacy check.			
Nuts and bolts	Check and tightening.			
Spokes	Tension check.			
Stem / Saddle seat post	Removing and applying new assembly paste.			
Circuit / Brakes	Disassembly and greasing.			
	Check the connections.			
Components of the electrical assistance system	Check there is no dirt.			

 You do not need to take the bicycle to an expert if you are skilled, experienced and have the appropriate tools. Immediately implement the corrective measures if you detect problems. If you are unsure or have queries, please contact BH.

 The tasks described above must only be carried out by a trusted bike repair expert.

## SPARE PARTS

Original parts must be used to ensure the optimum performance of your bicycle and the utmost safety. Failure to use original parts may cause damage that is not covered by the warranty.

The most common spare parts are parts prone to wear. The most common ones are tyres, inner tubes, brake pads, disc brakes and brake pads, as well as rims, when these are part of the brake unit, headlights, position lights, batteries and accumulators.

- **TYRES:** Replace them with an equivalent type of tyre. Check the marking on the outside of the tyre (ETRTO standard). Keep in mind that using a tyre with a larger outer diameter than the recommended one may cause the tip of the foot to touch the front wheel or rear wheel guard when the handlebars turn. The cyclist may lose control of the bicycle and suffer an accident with serious consequences. This can also occur when the pedal chainset is replaced with a longer one.
- **INNER TUBES:** Replace them with a suitable type of inner tube, according to the type of tyre. Refer to the information on the outside of the inner tube (ETRTO standard).
- **DISC BRAKES AND BRAKE PADS:** Follow the instructions supplied by the manufacturer.
- **HEADLIGHTS AND POSITION LIGHTS:** Replace the bulb with one of the same type. Check the indication on the metal area.

- **CHAIN, COG AND CHAIN RINGS:** Follow the instructions supplied by the manufacturer.
- **BATTERIES AND ACCUMULATORS:** Change for the same type. Check the indication on the outer area.

 Remember that the failure to use original parts may cause damage that is not covered by the warranty.

## AFTER A FALL, BLOW OR IMPACT

If you suffer a fall, blow or impact, first make sure that you are okay to continue cycling. Do not use the bike if you are injured and ask for medical assistance if needed.

If you are okay to continue cycling, check the bicycle to make sure that it is in perfect working order:

- Check that the wheels are firmly secured and that the rims are in the centre of the frame and fork. Turn the wheels. If they cannot be centred in situ because the gap is too small, separate the brakes from the rim so it can move freely.

 In this case, keep in mind that the braking efficacy will be less.

- Check whether the handlebars or the front of the frame are twisted or broken. Check that the front is firmly seated on the fork, holding the front wheel firmly between your legs and trying to twist the handlebars with respect to the front wheel.
- Check that the chain is fitted correctly. If the bicycle fell onto the transmission side, check that it is working properly. Ask for help to place the bicycle on its saddle and change gears. When the chain fits on the largest cog, check the distance between the gear and the spokes. If the gear or bracket are bent, the first one may become stuck on the spokes - Danger of falling! The gear, rear wheel or frame may be damaged. Check the derailleur. If it has shifted, the chain may come off the gear. The bicycle's transmission will become less effective (also refer to the "Traction" section).
- Check the saddle, upper tube or the bottom bracket box to make sure that there are no defects.
- Lift the bicycle slightly and let it drop onto the ground. If there are any noises, inspect the bicycle for any loose bolts.
- Inspect the entire bicycle again to check for bent areas, worn finish or cracks.
- Ride again carefully if no problems have been detected during the inspection. Do not brake or accelerate suddenly or pedal when going uphill. If you are unsure, wait for a car to pick you up instead of risking an accident. Once home, you should inspect the bicycle carefully again. If you are still unsure or have any queries, please contact your nearest BH workshop!

 Bent aluminium parts must not be straightened, i.e., they must not be repaired. Even afterwards, there is a high risk of breakage, especially in regards to the fork, handlebars, front part, chainsets and pedals. Replace them for greater safety.

## 07 WARNINGS ON USE

### MAXIMUM TYRE SIZE

If you install a tyre of a different size on your bicycle, check and make sure that there are at least 6 mm between the tyre and other parts of the frame and fork.

### MINIMUM AND MAXIMUM INSERTION LENGTH OF THE SEAT POST

Failure to observe the maximum and minimum seat post insertion dimensions indicated in this manual may cause a lever effect on the frame. The pressure exerted could damage the frame and cause serious accidents. The warranty does not cover the damage generated by failing to observe these indications.

### MAXIMUM FORK LENGTH (AXLE-TO-CROWN)

Observe the maximum length between the fork axle and the lower part of the steering tube (axle-to-crown). If this maximum length is not observed, the frame could be damaged due to withstanding a greater load than that for which it was designed and may cause serious accidents.

### MAXIMUM NUMBER OF STEERING SPACERS

This manual specifies the maximum number of steering spacers that can be fitted under the stem. If this maximum quantity is not observed, the materials could be damaged due to withstanding a greater load than that for which they were designed and may cause serious accidents.

### POSITION OF THE SPINDLE INSIDE THE FORK TUBE

No steering spacers must be fitted above the stem. Otherwise, the materials could be damaged due to withstanding a greater load than that for which they were designed and may cause serious accidents.

### INTENDED USE

Each bicycle has been designed according to a specific intended use. Ride each bicycle model according to its intended use. Refer to the section "INTENDED USE" of this manual for more information about the different types of intended use.

## 08 WARNINGS ON USE OF THE ELECTRICAL ASSISTANCE SYSTEM

### CARE AND INSTRUCTIONS FOR USE OF THE ELECTRICAL COMPONENTS AND BATTERIES

All BH products and parts have been designed to withstand splashed liquids and rain. However, some practices may cause damage to the parts and short circuits. Do not do the following:

- Wash the bicycle with pressure devices.
- Use the bicycle under adverse weather conditions.
- Transport the bicycle on the outside of a vehicle when it is raining.
- Expose the batteries to very high temperatures. If the temperature exceeds 70°C, this could cause leaks and there could be a risk of fire.
- Fail to observe the working temperature, storage and charging range of the bicycle.

### RECOMMENDATIONS TO MAXIMISE THE BATTERY LIFE

We recommend the following to maximise the battery life:

- Charge it on a flat and stable surface.
- Make sure that it is not exposed to direct sunlight.
- Make sure that there are no children or pets near.
- Make sure that there is no rain or dampness.
- The place must be well ventilated and dry.
- The temperature must be between 15-25°C.
- Do not use the battery with a charge of less than 10%. The useful life of the cells may be affected below this charge level.

 Any unauthorised handling of the electrical system's components may cause serious accidents and will void the warranty.

### WARNINGS ON THE USE OF BATTERIES

Improper use of the batteries may cause damage and serious accidents. Follow these recommendations to prevent this:

- Always use the original battery charger.
- Never leave the battery near sources of heat.
- Do not heat the battery or throw it into a fire.

- Prevent the battery connections from coming into contact with metal objects.
- Do not submerge the battery in water and prevent splashes and dampness.
- Do not hit or drill holes into the battery.
- Make sure that the battery liquid does not touch your hands or eyes in the event of a leak.
- Do not use it if there are external signs of damage.
- Only clean the battery with a dry or damp cloth.

### UNSUITABLE CHARGING AND DISCHARGING ENVIRONMENTS AND SOLUTIONS

The hot and cold environments described below may lead to charging entering standby or sleep mode without fully charging the battery.

- **Winter discharging sleep mode or DUT (Discharge Under Temperature):** Battery discharging will enter the deep sleep mode if the temperature is below -20°C, stopping the pedal assistance system from working and protecting the battery. In such cases, sleep mode will automatically be disabled when the battery exceeds -20°C.
- **Winter charging sleep mode or CUT (Charge Under Temperature):** Battery charging will enter sleep mode if the temperature is below 0°C. If charging starts and the temperature falls below this level due to night cooling or other factors, charging will stop and sleep mode will be activated to protect the battery. In such cases, sleep mode will automatically be disabled when the battery exceeds 0°C.
- **Noise on televisions/radios/computers:** Charging near televisions, radios or similar devices may cause static electricity, flickering images and other interference. If this happens, recharge somewhere that is away from the television or radio (e.g. in another room).

### RECYCLING

Ion-lithium batteries can be recycled but they may harm the environment if they are not managed properly after the end of their service life. Follow these steps after the end of their service life:

- Classify and recycle each electrical component in a place prepared for the sustainable recycling of such parts.
- Check and make sure that the applicable regulations of your country are observed with regards to batteries.

### MOTOR

The DC motor is located on the bottom bracket axle. The motor's service life depends on its use, as in the case of any other part of the bicycle. Under normal conditions, the motor can last for 10 to 20 years, or up to 100,000 km.

## 09 BH WARRANTY

BH BIKES undertakes to offer long-lasting bicycles, in compliance with the highest standards of quality. Therefore, in addition to the statutory warranty, BH BIKES offers an additional coverage and warranty. This section defines the different types of warranty and the process that must be followed to register for the additional "LifeTime Frame" warranty.

### STATUTORY WARRANTY

The statutory warranty covers the original purchaser in the event of manufacturing defects and/or non-conformities. This warranty applies to frames and components manufactured by BH BIKES. The warranty period will be established according to the current laws of the country where the bicycle was purchased, and will start on the date of purchase. During this period, the holder of the warranty will be entitled to have all manufacturing defects repaired or replaced free of charge, including the reimbursement of transport expenses and any losses caused as a result of this. Different conditions must be met in order to be covered by the warranty:

- This warranty does not affect the consumer's applicable rights, according to the current laws in each country.
- Faulty bicycles or parts will be covered by warranty upon the decision of our Technical Service.
- The warranty does not include the replacement of parts prone to wear and arising from normal use of the bicycle.
- The warranty does not cover defects or broken parts due to improper use of the bicycle, use for competitions, mounting of non-original accessories or improper handling and incorrect maintenance work.
- The warranty does not apply if the inspection before delivery and the corresponding inspection intervals included in this document have not been carried out, observed, documented as required and stamped by an authorised BH dealer.
- Should the repair not be satisfactory and not ensure that the optimum conditions are met according to the intended use, the holder of the warranty will be entitled to request the replacement of the purchased item or faulty part with one of identical characteristics, or to receive a refund of the amount paid for the damaged item or part.
- The warranty period will be interrupted during the repairs or, in the event of replaced items or components, it will be renewed.
- Any claim against this warranty shall expire six months after the end of the warranty validity period.
- All warranty claims must be processed by an authorised dealer.
- Geographical scope: refer to the User Manual or [www. BHbikes.com](http://www.BHbikes.com)

Visit the following link to read the terms and conditions:

[https://www.bhbikes.com/es\\_INT/registro-garantia-vida-bh/registra-tu-bici-garantia-de-por-vida](https://www.bhbikes.com/es_INT/registro-garantia-vida-bh/registra-tu-bici-garantia-de-por-vida)

### LIFETIME FRAME WARRANTY

Through its authorised stores, BH Bikes provides the original buyer with a commercial policy to cover any manufacturing defects in frames for a period beyond that specified in the product's statutory warranty, pursuant to the following clauses:

1. **The LIFETIME warranty solely applies to BH frames and bikes that are sold through stores that are authorised by BHBIKES EUROPE S.L.**
  - The buyer must register the LIFETIME warranty online, with the information duly completed, within 30 calendar days of the purchase date, as it appears on the invoice issued by the authorised store.
  - This warranty cannot be transferred to subsequent buyers and it is cancelled when the bicycle is sold to a third party. Original buyer means the individual who registers the warranty at the time of the purchase; the commercial warranty cannot be transferred to third parties who are not the original buyer.
  - It shall be compulsory to have the bicycle serviced in an establishment that is authorised by BHBIKES EUROPE and according to the instructions in the user manual.
2. **The LIFETIME warranty does not cover:**
  - The rear swingarms of the double suspension models, fork, kids' bikes, defects and/or fading of the original paint, or rust caused by natural deterioration.
  - Defects or breakages resulting from an accident or improper and/or negligent use of the bicycle.
  - When components or accessories that are not intended for or are not compatible with the use for which the bicycle was designed have been installed.
  - Defects resulting from improper handling.
  - Scratches, discolouration, or stains caused by the use of abrasive fluids, sharp items, clamps and/or prolonged exposure to sunlight or other weather conditions.
  - Defects caused by the bicycle's normal wear and tear, including those due to material fatigue. Fatigue damage is a sign that the frame has been damaged by normal use, so it is the user's responsibility to regularly inspect the bicycle.
  - Improper use and/or maintenance of the product (carefully read the recommendations for use and cleaning).
  - Frames that have been used in competitions, demos or as rentals.

Read the full terms and conditions at:

[https://www.bhbikes.com/es\\_INT/registro-garantia-vida-bh/registra-tu-bici-garantia-de-por-vida](https://www.bhbikes.com/es_INT/registro-garantia-vida-bh/registra-tu-bici-garantia-de-por-vida)

## EXTENDED WARRANTY OF UP TO 5 YEARS ON BH MOTORS

Activating the LIFETIME FRAME extended warranty will automatically activate a 5-year extended warranty for all BH motors. Through its authorised stores, BH Bikes provides the original buyer with a commercial policy to cover any manufacturing defects in BH motors for a period beyond that specified in the product's statutory warranty, pursuant to the following clauses:

- The BH motor extended warranty solely applies to BH motors installed in BH bikes and sold through stores that are authorised by BHBIKES EUROPE S.L.**
  - The buyer must register the warranty online, with the information duly completed, within 30 calendar days of the purchase date, as it appears on the invoice issued by the authorised store, on which the bike's serial no. must be specified.
  - This warranty cannot be transferred to subsequent buyers and it is cancelled when the bicycle is sold to a third party. Original buyer means the individual who registers the warranty at the time of the purchase; the commercial warranty cannot be transferred to third parties who are not the original buyer.
  - It shall be compulsory to have the bicycle serviced in an establishment that is authorised by BHBIKES and according to the instructions in the user manual.
- The BH motor extended warranty shall not ever cover:**
  - Fading paintwork and a loss of original colour, or corrosion caused by normal wear and tear.
  - Defects or breakages resulting from an accident or improper and/or negligent use of the bicycle.
  - When components or accessories have been installed that are not intended for/compatible with the use for which the bicycle was designed, and when the motor has been tampered with and/or de-limited.
  - Defects resulting from improper handling.
  - Scratches, discolouration, or stains caused by the use of abrasive fluids, sharp items, clamps and/or prolonged exposure to sunlight or other weather conditions.
  - Improper use and/or maintenance of the product (carefully read the recommendations for use and cleaning).
  - Motors that have been used in competitions, demos or in rentals.
  - Motors mounted on bicycles of the MONTY range.

Read the full terms and conditions at:

[https://www.bhbikes.com/es\\_INT/registro-garantia-vida-bh/registra-tu-bici-garantia-de-por-vida](https://www.bhbikes.com/es_INT/registro-garantia-vida-bh/registra-tu-bici-garantia-de-por-vida)

## EXTENDED WARRANTY FOR BH BATTERIES

In a constant effort to improve our customer services on a daily basis, BH offers the best warranty conditions and the possibility of acquiring an extended warranty for its e-Bike range (an additional one or two years). Through its authorised stores, BH Bikes provides the original buyer with a commercial policy to cover any manufacturing defects in BH batteries for a period beyond that specified in the product's statutory warranty, pursuant to the following clauses:

- The BH battery extended warranty solely applies to BH batteries installed in BH bikes and sold through stores that are authorised by BHBIKES EUROPE S.L:**
  - The buyer must register the warranty online, with the information duly completed, within 30 calendar days of the purchase date, as it appears on the invoice issued by the authorised store, on which the bike's serial no. must be specified.
  - This warranty cannot be transferred to subsequent buyers and it is cancelled when the bicycle is sold to a third party. Original buyer means the individual who registers the warranty at the time of the purchase; the commercial warranty cannot be transferred to third parties who are not the original buyer.
  - It shall be compulsory to have the bicycle serviced in an establishment that is authorised by BHBIKES and according to the instructions in the user manual.
- The BH battery extended warranty shall not ever cover:**
  - Fading paintwork and a loss of original colour, or corrosion caused by normal wear and tear.
  - Defects or breakages resulting from an accident or improper and/or negligent use of the bicycle.
  - Deterioration or natural degradation due to age, even without use. Deterioration after 500 full charging and discharging cycles if it is below 30% of the nominal capacity (read the recommendations in the user manual carefully).
  - When components or accessories have been installed that are not intended for/compatible with the use for which the bicycle was designed.
  - Defects resulting from improper handling.
  - Scratches, discolouration, or stains caused by the use of abrasive fluids, sharp items, clamps and/or prolonged exposure to sunlight or other weather conditions.
  - Improper use and/or maintenance of the product (carefully read the recommendations for use and cleaning).
  - Batteries that have been used in competitions, demos or in rentals.
  - Auxiliary batteries (extenders).

Read the full terms and conditions at:

[https://www.bhbikes.com/es\\_INT/registro-garantia-vida-bh/extension-garantia-bateria](https://www.bhbikes.com/es_INT/registro-garantia-vida-bh/extension-garantia-bateria)

## REGISTERING EXTENDED WARRANTIES

You must register the bicycle within 30 days after purchase to enjoy the BH BIKES additional warranties. The process to activate the extended warranties is described below:

- **LIFETIME FRAME WARRANTY + 5 YEARS WARRANTY ON BH ENGINES**

You must register the bicycle on the BH BIKES website to enjoy the LIFETIME FRAME extended warranty:

[https://www.bhbikes.com/es\\_INT/registro-garantia-vida-bh/registra-tu-bici-garantia-de-por-vida](https://www.bhbikes.com/es_INT/registro-garantia-vida-bh/registra-tu-bici-garantia-de-por-vida)

Watch this video to find out what you need to do:

<https://youtu.be/47aLVgUI248>



- **EXTENDED WARRANTY FOR BH BATTERIES**

You must register the bicycle on the BH BIKES website to enjoy the BH BATTERY extended warranty:

[https://www.bhbikes.com/es\\_INT/registro-garantia-vida-bh/extension-garantia-bateria](https://www.bhbikes.com/es_INT/registro-garantia-vida-bh/extension-garantia-bateria)

Watch this video to find out what you need to do:

<https://youtu.be/sINzdFBygMM>



⚠ The serial number required to register the bicycle is located on the bottom of the bicycle, near the bottom bracket:

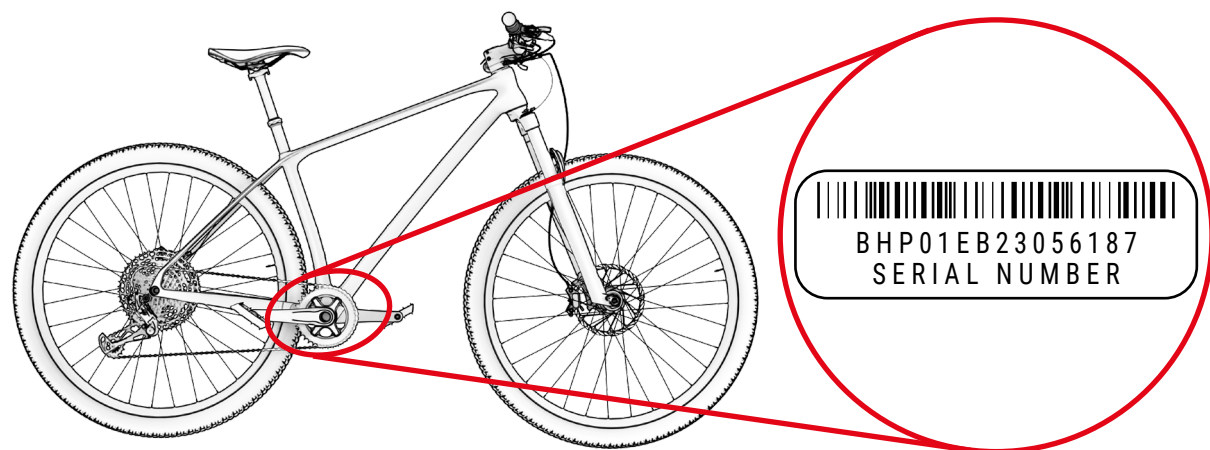

## WARRANTY OF PARTS OF THE ELECTRICAL ASSISTANCE SYSTEM

As in the case of BH BIKES frames and parts, all electrical components made exclusively for BH will be covered by the statutory warranty (BH motors feature an extended 5-year warranty after the LIFETIME FRAME warranty is activated). The warranty period will be established according to the current laws of the country where the bicycle was purchased, and will start on the date of purchase.

During this period, the holder of the warranty will be entitled to have all manufacturing defects repaired free of charge, including the reimbursement of transport expenses and any losses caused as a result of this. The terms and conditions are as described in the section "Statutory Warranty" and can be read at:

<https://www.bhbikes.com/manuals>

Under no circumstances shall the warranty cover the wear and natural ageing of batteries due to use, charging and storage. Likewise, the buyer must contact the original manufacturer to use the warranty of third-party parts.

## SUBMITTING A WARRANTY CLAIM

All warranty claims must be channelled through an official BH dealer. The dealer will analyse the claim to identify its scope and perform a preliminary assessment of the incident. The dealer will submit and process the claim directly with BH. Once BH has defined the corrective measures required, the dealer will send this information to the customer.

All claims must be processed by the official dealer from which you purchased your bicycle. If this is not possible, please contact us directly. We will help you find an authorised dealer near you:

[https://www.bhbikes.com/es\\_INT/quienes-somos/contacto](https://www.bhbikes.com/es_INT/quienes-somos/contacto)

## CONDITIONS THAT MAY VOID THE WARRANTY OF ELECTRICAL COMPONENTS

The BH battery and electrical components are covered by the statutory warranty, but the following requirements must be met:

- No electrical components must be removed or tampered with.
- The service life will vary according to the use, charging and storage conditions.
- Keep the battery charged at all times. Otherwise, the battery may deteriorate faster than normal.

## EU Declaration of Conformity

**The manufacturer:** BH BIKES EUROPE, SL  
c/ Perretagana 10,  
01015 Vitoria, Spain

Hereby declares that the following products:

**Product description:**  Cycles –Electrically power assisted cycles –EPAC Bicycles

**Models designation:**

Atom 27,5, Atom 29, Atom City, Atom City Pro, Atom City Wave, Atom City Wave Pro, Atom Cross, Atom Cross Pro, Atom Diamond Wave Pro, Atom Jet, Atom Jet Pro, Atom Lynx 5.5, Atom Lynx 5.5 Pro, Atom Lynx 8.0, Atom Lynx 8.1, Atom Lynx 8.2 Pro, Atom Pro, Atom Street, Atom Street Pro, Atom Suv Pro.

AtomE City Wave Pro, AtomE Diamond Wave Pro, AtomE Cross Pro, AtomE Jet Pro, AtomE Lynx 8.0, AtomE Lynx 8.2, AtomE Pro, AtomE Suv Pro, AtomE Suv Pro-S, AtomE Suv Pro-SE.

AtomS 27,5 Pro, AtomS 29 Pro, AtomS City Wave Pro, AtomS City Wave Pro-S, AtomS Cross Pro, AtomS Cross Pro-S, AtomS Diamond Pro, AtomS Diamond Wave Pro, AtomS Diamond Wave Pro-S, AtomS Jet Pro, AtomS Jet Pro-S, AtomS Pro, AtomS Pro-S, AtomS Street Pro, AtomS Suv Pro, AtomS Suv Pro-S.

AtomX Carbon Lynx 5.5 Pro, AtomX Carbon Lynx 5.5 Pro-S, AtomX Carbon Lynx 6 Pro, AtomX Carbon Lynx 6 Pro-S, AtomX Carbon Lynx 6 Pro-SE, AtomX Cross Nitro, AtomX Cross Pro, AtomX Cross Pro-S, AtomX Lynx 5.5 Pro, AtomX Lynx 5.5 Pro-L, AtomX Lynx 5.5 Pro-S, AtomX Lynx 6 Pro, AtomX Lynx 6 Pro-S, AtomX Lynx 6 Pro-SE, AtomX Lynx Pro 8.2, AtomX Lynx Pro 8.4, AtomX Lynx Pro 9.0, AtomX Lynx Pro 9.2, AtomX Lynx Pro 9.4, AtomX Lynx Carbon Pro 8.7, AtomX Lynx Carbon Pro 8.8, AtomX Lynx Carbon Pro 9.7, AtomX Lynx Carbon Pro 9.8, AtomX Lynx Carbon Pro 9.9, AtomX Pro, AtomX Pro-S.

Core 29, Core Pro, Core City Wave, Core Cross, Core Gravel X 2.2, Core Gravel X 2.4, Core Gravel X Carbon 2.6, Core Gravel X Carbon 2.7 Pro, Core Jet, Core Pro, Core Race 1.2, Core Race 1.4, Core Race Carbon 1.5, Core Race Carbon 1.6, Core Race Carbon 1.8, Core Race Carbon 1.8 Pro, Core Race Carbon 1.9 Pro, Core Street.

iLynx Race Carbon 7.6 LT, iLynx Race Carbon 7.7 LT, iLynx Race Carbon 7.8 LT Pro, iLynx Race Carbon 7.9 Pro, iLynx Race Carbon 8.0 LT, iLynx Race Carbon 8.2 LT, iLynx Race Carbon 8.4 LT Pro, iLynx Race Carbon 8.6 Pro, iLynx Trail 8.0, iLynx Trail 8.1, iLynx Trail 8.2, iLynx Trail Carbon 8.6, iLynx Trail Carbon 8.7, iLynx Trail Carbon 8.8 Pro, iLynx Trail Carbon 8.9 Pro.

iLynx+ Trail Carbon 8.7, iLynx+ Trail Carbon 8.8, iLynx+ Trail Carbon Pro 8.9, iLynx+ Enduro Carbon 9.7, iLynx+ Enduro Carbon 9.8, iLynx+ Enduro Carbon Pro 9.9.

iAerolight 1.7, iAerolight 1.8, iAerolight Pro 1.9.

Xtep Carbon Lynx 5.5 Pro, Xtep Carbon Lynx 5.5 Pro-S, Xtep Carbon Lynx 6 Pro, Xtep Carbon Lynx 6 Pro-S, Xtep Carbon Lynx 6 Pro-SE, Xtep Cross Pro, Xtep Lynx 5.5 Pro, Xtep Lynx 5.5 Pro-L, Xtep Lynx 5.5 Pro-S, Xtep Lynx 5.5 Pro-SE, Xtep Lynx Carbon 8.7 Pro, Xtep Lynx Carbon 8.8 Pro, Xtep Lynx Carbon 9.7 Pro, Xtep Lynx Carbon 9.8 Pro, Xtep Lynx Carbon 9.9 Pro, Xtep Pro-S, Xtep Lynx Carbon Pro 0.7, Xtep Lynx Carbon Pro 0.8, Xtep Lynx Carbon Pro 0.9.

**Year of manufacture:** 2022 and 2023

Comply with all of the relevant requirements of the Machinery Directive (2006/42/EC).  
Comply with Low Voltage Directive (LVD) 2014/35/EU  
Comply with all of the relevant requirements of RD 339/2014, de 9 de Mayo.

Furthermore, the machine complies with all of the requirements of the Electromagnetic Compatibility Directive 2014/30/EU.

The production control is assured by our Quality Management System, which fulfills the requirements of the standard ISO 9001

The following harmonized standards have been applied:  
DIN EN 15194 Cycles – Electrically power assisted cycles – EPAC bicycles;  
DIN ISO 4210-1/2/3/4/5/6/7/8/9 Safety requirements for bicycles

**Technical documentation filed at:**

BH BIKES EUROPE, SL  
c/ Perretagana 10,  
01015 Vitoria, Spain



José María Chapinal  
Quality Manager  
BH BIKES EUROPE, SL

## Declaration of Conformity

**The manufacturer:**

BH BIKES EUROPE, SL  
c/ Perretagana 10,  
01015 Vitoria, Spain

Hereby declares that the following products:

**Product description:**  Bicycles  
**Models designation:**

**MOUNTAIN BICYCLES:**

Expert 4.0, Expert 4.5, Expert 5.0, Expert 5.5, Lynx 5 Alu 5.0, Lynx 5 Carbon 7.0, Lynx Race Alu 3.0, Lynx Race Alu 3.5, Lynx Race Carbon MC 3.0, Lynx Race Carbon MC 3.5, Lynx Race Carbon MC 4.0, Lynx Race Carbon MC 4.5, Lynx Race Carbon RC 6.0, Lynx Race Carbon RC 6.0 LT, Lynx Race Carbon RC 6.5, Lynx Race Carbon RC 6.5 LT, Lynx Race Carbon RC 7.0, Lynx Race Carbon RC 7.5 LT, Lynx Race Evo Carbon 8.0, Lynx Race Evo Carbon 8.5, Lynx Race Evo Carbon 9.0 LT, Lynx Race Evo Carbon 9.2, Lynx Race Evo Carbon 9.2 LT, Lynx Race Evo Carbon 9.5, Lynx Race Evo Carbon 9.9, Lynx Race Evo Carbon 9.9 LT, Lynx Trail Carbon 9.0, Lynx Trail Carbon 9.5, Lynx Trail Carbon 9.9, Spike 1.0, Spike 2.0, Spike 2.5, Spike 3.0, Ultimate Evo 8.0, Ultimate Evo 8.5, Ultimate Evo 9.0, Ultimate Evo 9.5, Ultimate Evo 9.9, Ultimate RC 6.5, Ultimate RC 7.0, Ultimate RC 7.5, Ultimate RC 7.7.

**RACING BICYCLES:**

Aerolight 6.0, Aerolight 6.5, Aerolight 7.0, Aerolight 7.5, Aerolight Disc 4.0, Aerolight Disc 4.0 BHU, Aerolight Disc 5.0, Aerolight Disc 5.0 BHU, Aerolight Disc 6.0, Aerolight Disc 6.0 BHU, AeroTT Disc 4.0, AeroTT Disc 5.0, AeroTT Disc 6.0, G8 6.0, G8 6.5, G8 7.0, G8 7.0 BHU, G8 7.5, G8 7.5 BHU, Gravel X Alu 1.0, Gravel X Alu 2.0, Gravel X Alu 2.5, Gravel X Carbon 3.0, Gravel X Carbon 3.5, Gravel X Carbon 4.0, Gravel X Carbon 4.5, Quartz 2.0, Quartz 2.5, Quartz 3.0, Quartz 4.0, Quartz 4.5, Quartz SL 1.0, Quartz SL 1.5, RS1 3.0, RS1 3.5, RS1 4.0, RS1 4.5, RS1 5.0, RX Team 3.0, RX Team 4.0, RX Team 5.0, RX Team 5.5, RX Team 6.0, SL1 2.0, SL1 2.5, SL1 2.9, Ultralight Evo 8.0, Ultralight Evo 8.0 No ACR, Ultralight Evo 8.5, Ultralight Evo 9.0, Ultralight Evo 9.5.

**CITY AND TREKKING BICYCLES:**

Oxford, Oxford Jet, Oxford Jet Lite, Oxford Jet Pro, Oxford Lite, Oxford Pro, Silvertip, Silvertip Jet, Silvertip Jet Lite, Silvertip Jet Pro, Silvertip Lite, Silvertip Pro.

**YOUNG CHILDREN AND YOUNG ADULTS BICYCLES:**

Expert 26" Disc, Expert Junior 14", Expert Junior 16", Expert Junior 18", Expert Junior 20", Expert Junior 20" Pro, Expert Junior 20" Sus, Expert Junior 24", Expert Junior 24" Disc, Expert Junior 24" Pro, Expert Junior 26", Expert Junior 26" Pro.

**Year of manufacture:** 2022 and 2023

Comply with all of the relevant requirements of RD 339/2014, de 9 de Mayo.

The production control is assured by our Quality Management System, which fulfills the requirements of the standard ISO 9001

The following harmonized standards have been applied:

ISO 4210-1/2/3/4/5/6/7/8/9 – Safety requirements for bicycles  
ISO 8098 Safety requirements for bicycles for young children  
EN 16054 BMX bicycles. Safety requirements and test methods

**Technical documentation filed at:**

BH BIKES EUROPE, SL  
c/ Perretagana 10,  
01015 Vitoria, Spain



José María Chapinal  
Quality Manager  
BH BIKES EUROPE, SL



[www.bhbikes.com](http://www.bhbikes.com)

