

CONTENTS

01 INTRODUCCIÓN	3
SYMBOLS	3
02 MAINTENANCE	4
INSPECT THE BICYCLE BEFORE USE	4
KEEP THE BICYCLE CLEAN.....	4
AFTER A FALL, BLOW OR IMPACT.....	5
03 WARNING ON USE	5
MAXIMUM NUMBER OF STEERING SPACERS	5
POSITION OF THE SPINDLE INSIDE THE FORK TUBE	5
04 SIZES AND DIMENSIONS	5
05 ASSEMBLY AND SPARE PARTS	6
DIMENSIONS OF THE STEERING PIPE	6
HEADSET ASSEMBLY.....	6
HANDLEBAR ASSEMBLY	7
HANDLEBAR CABLEROUTING	7
06 HELP AND ADDITIONAL RESOURCES	8

01 INTRODUCCIÓN

This user manual contains important and specific information for the proper use and maintenance of the **EVO SL handlebar**. It is strongly recommended to read the entire manual carefully. User manuals for all BH models are available online at the following address:

<https://www.bhbikes.com/manuals>

Please note that the manuals are periodically updated on the BH BIKES website; always ensure you have the latest version. Refer to the version indicated on the cover page.

This document contains supplementary information to the general user manual, available at:

https://www.bhbikes.com/es_ES/quienes-somos/manuales-descargas

For specifications, recommendations, and warranty information regarding third-party components, please refer to their respective official websites.

SYMBOLS

This document contains different icons that refer to use, maintenance and assembly warnings. Carefully read the meaning of each one to prevent improper handling or hazardous situations that may result in serious personal injuries or fatal accidents.

SAFETY

 **DANGER:** refers to a hazardous situation that, if not avoided, will lead to serious injuries or even a fatal accident.

 **WARNING:** refers to a hazardous situation that, if not avoided, could lead to serious injuries or even a fatal accident.

 **ATTENTION:** refers to a hazardous situation that, if not avoided, could cause minor or moderate injuries.

 **RISK OF ELECTRIC SHOCK:** refers to a hazardous situation that, if not avoided, could cause serious injuries due to electric shock or even death.

 **RISK OF SHORT CIRCUIT:** refers to a hazardous situation that, if not avoided, could cause short circuits in the electrical components. Short circuits may cause damage to the electrical components and fire.

TOOLS

 **FLAT WRENCH**

 **ALLEN KEY**

 **TORX KEY**

 **PHILLIPS SCREWDRIVER**

 10Nm **TIGHTENING TORQUES:** on one side of each tool symbol, the tightening torque will be indicated in newton metre.

TYPE OF ASSEMBLY COMPOUND

 **OIL:** light lubrication for elements such as chains and cables.

 **GREASE:** assembly grease.

 **CARBON PASTE:** assembly paste used to increase the friction of the carbon elements.

 **ADHESIVE:** use medium strength thread lock.

 Adhesive is used to fasten bolts and make sure that they do not come loose due to vibrations when using the bicycle. Add a drop of thread lock to the tip of the screw thread in all cases. Never apply more than one drop around the thread, since this will make it very hard to remove the bolt.



02 MAINTENANCE

This user manual contains important information for the proper use of the handlebar. Please read the entire manual carefully. The user manuals of all BH models can be consulted on the website at the following address:

<https://www.bhbikes.com/manuals>

This document contains additional information to the general user manual, available at:

<https://www.bhbikes.com/manuals>

You can check the characteristics and recommendations of third-party parts on their corresponding official websites.

INSPECT THE BICYCLE BEFORE USE

Bicycles are inspected several times throughout the manufacturing process and then at the BH workshop during the final check. As the bicycle's operation may be affected during transport or third parties may have modified the bicycle before its sale, the following must be checked before each trip:

- **FRAME:** no cracks, damage or strange noises.
- **CHAIN:** it must be lubricated and the transmission system must not make any strange noises.
- **BRAKES:** the brakes must be working properly. When stopped, press the brake lever with enough strength and check that it does not touch the handlebars.
- **TYRES:** the pressure must be correct and there must be no cuts on the tread or on the sides. Also check that the wear level does not exceed the maximum recommended level.
- **WHEELS:** the wheels must rotate freely in order to check how they rotate. Also check the space between the brake lining and the rim, as well as the space between the frame and tyre.
- **STEERING:** the steering must turn smoothly and with no strange noises.
- **SWINGARM ROTATION POINTS:** when weight is exerted on the bicycle, the suspension must work as expected and with no strange noises. If it is not working properly or there is play between the moving parts, this might mean that the tightening torques are incorrect or that the bearings are worn.
- **BEARINGS:** the bearings must work properly and with no strange noises. The bearings are subject to wear and must be replaced to prevent damage to the components on which they are installed.
- **ELECTRICAL SYSTEM:** if the bicycle features an electrical system, check that it is functioning properly by ensuring that the electrical assistance mode is running and that all parts are functioning properly (motor, display, change of assistance mode and speed sensor). If there is no electrical assistance, check that all connections are correct and show no signs of damage.

⚠ Do not ride your bicycle if it does not meet any of these points! A faulty bicycle may cause serious accidents! If you are unsure or have any queries, please contact your nearest BH workshop!

⚠ Check the tightening torques to make sure that they are as described in the recommendations in the user manuals. Failure to observe these recommendations may result in accidents and even death.

⚠ The effect of the ground and the forces exerted on the wheel subject the bicycle to a lot of stress. The different parts will be subject to fatigue and wear because of these dynamic loads. Check the bicycle at regular intervals to look for signs of wear, scratches, bent parts, wear on the finish or the formation of cracks. Parts may fail suddenly after their service life has expired. Take your bicycle to an authorised BH workshop regularly to have these parts replaced if needed.

KEEP THE BICYCLE CLEAN

We recommend you follow these basic prevention measures to make sure that the bicycle is in perfect working order. Failure to observe these recommendations may lead to premature wear or even breakages in specific areas, such as gaskets or moving parts.

- Clean the dust and mud with a damp sponge and a gentle and neutral cleaning product.
- Plastic parts must only be washed with soapy water.
- Tyres can be washed with a sponge or brush and soapy water.
- After cleaning the bicycle, dry it by rubbing it firmly with a smooth cloth.
- After each cleaning, lubricate the transmission elements.

⚠ Dirt may cause damage that can result in accidents or even death.

⚠ Never use pressure washers or steam cleaners.

AFTER A FALL, BLOW OR IMPACT

If you suffer a fall, blow or impact, first make sure that you are okay to continue cycling. Do not use the bike if you are injured and ask for medical assistance if needed.

If you are okay to continue cycling, check the bicycle to make sure that it is in perfect working order:

- Check that the wheels are firmly secured and that the rims are in the centre of the frame and fork. Turn the wheels. If they cannot be centred in situ because the gap is too small, separate the brakes from the rim so it can move freely.

⚠ In this case, keep in mind that the braking efficacy will be less.

- Check whether the handlebars or the front of the frame are twisted or broken. Check that the front is firmly seated on the fork, holding the front wheel firmly between your legs and trying to twist the handlebars with respect to the front wheel.
- Check that the chain is fitted correctly. If the bicycle fell onto the transmission side, check that it is working properly. Ask for help to place the bicycle on its saddle and change gears. When the chain fits on the largest cog, check the distance between the gear and the spokes. If the gear or bracket are bent, the first one may become stuck on the spokes - Danger of falling! The gear, rear wheel or frame may be damaged. Check the derailleur. If it has shifted, the chain may come off the gear. The bicycle's transmission will become less effective (also refer to the "Traction" section).
- Check the saddle, upper tube or the bottom bracket box to make sure that there are no defects.
- Lift the bicycle slightly and let it drop onto the ground. If there are any noises, inspect the bicycle for any loose bolts.
- Inspect the entire bicycle again to check for bent areas, worn finish or cracks.
- Ride again carefully if no problems have been detected during the inspection. Do not brake or accelerate suddenly or pedal when going uphill. If you are unsure, wait for a car to pick you up instead of risking an accident. Once home, you should inspect the bicycle carefully again. If you are still unsure or have any queries, please contact your nearest BH workshop!

⚠ Bent aluminium parts must not be straightened, i.e., they must not be repaired. Even afterwards, there is a high risk of breakage, especially in regards to the fork, handlebars, front part, chainsets and pedals. Replace them for greater safety.

03 WARNING ON USE

MAXIMUM NUMBER OF STEERING SPACERS

This manual specifies the maximum number of steering spacers that can be fitted under the stem. If this maximum quantity is not observed, the materials could be damaged due to withstanding a greater load than that for which they were designed and may cause serious accidents.

POSITION OF THE SPINDLE INSIDE THE FORK TUBE

No steering spacers must be fitted above the stem. Otherwise, the materials could be damaged due to withstanding a greater load than that for which they were designed and may cause serious accidents.

04 SIZES AND DIMENSIONS

EVO SL HANDLEBAR

ALL MODELS

A STEM (mm)	80	90	100	110	120
B WIDTH (mm)	380	400	420	420	440

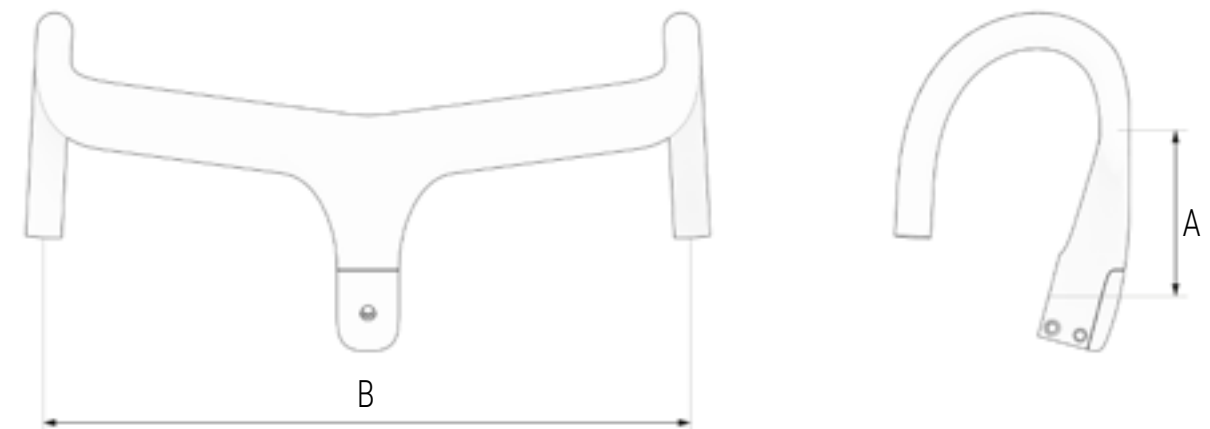

05 ASSEMBLY AND SPARE PARTS

DIMENSIONS OF THE STEERING PIPE

ALL MODELS

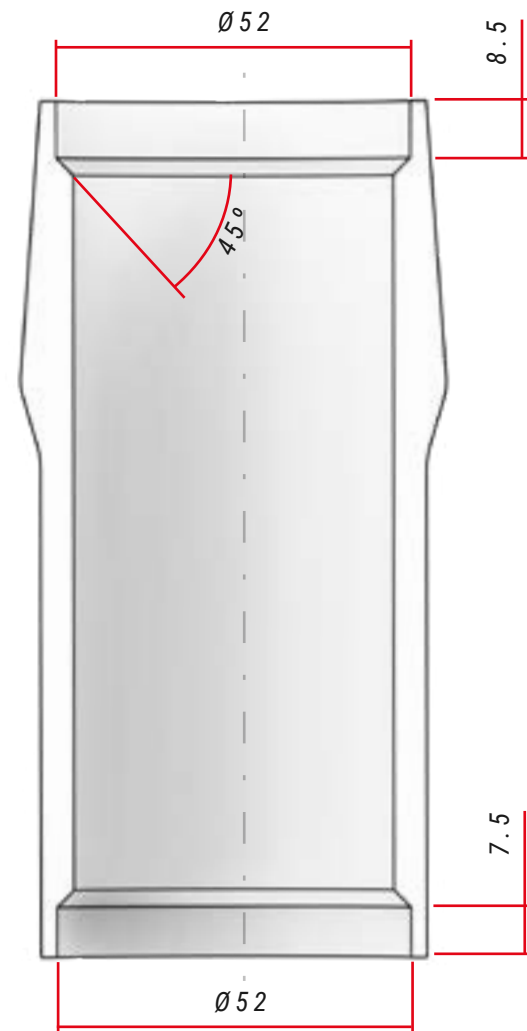

STEERING SPECIFICATIONS

Type		Contact angle with the compression ring / fork track	Bearing dimensions
Upper	1.5" Steerer	45°	52x40x7
Lower	1.5" Steerer	45°	52x40x7

HEADSET ASSEMBLY

ALL MODELS

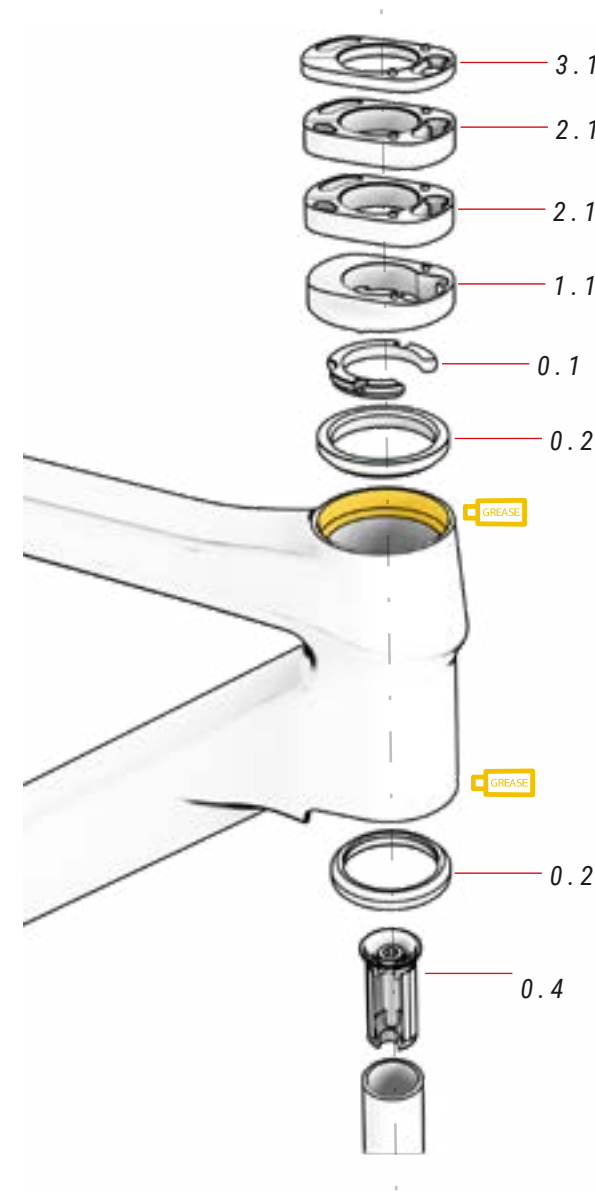

00 HEADSET

ref.: 383240700

No.	Item	Quantity
0.1	Compressor	1
0.2	Bearing	2
0.3	Washer (Do not assemble)	1
0.4	Expander	1



⚠ Carbon forks must never be mounted with a spindle. The spindle may force the fork with a pressure for which it has not been designed. It may break and cause an accident.

Always mount the fork with an expander.

01 ACR STEERING COVER ref.: 383240800

Item	Quantity
1.1 Steering cover 10 mm	1

02 ACR SPACER ref.: 383240900

Item	Quantity
2.1 Spacer 10 mm	2

03 ACR SPACER ref.: 383241000

Item	Quantity
3.1 Spacer 5 mm	1

HANDLEBAR ASSEMBLY

ALL MODELS

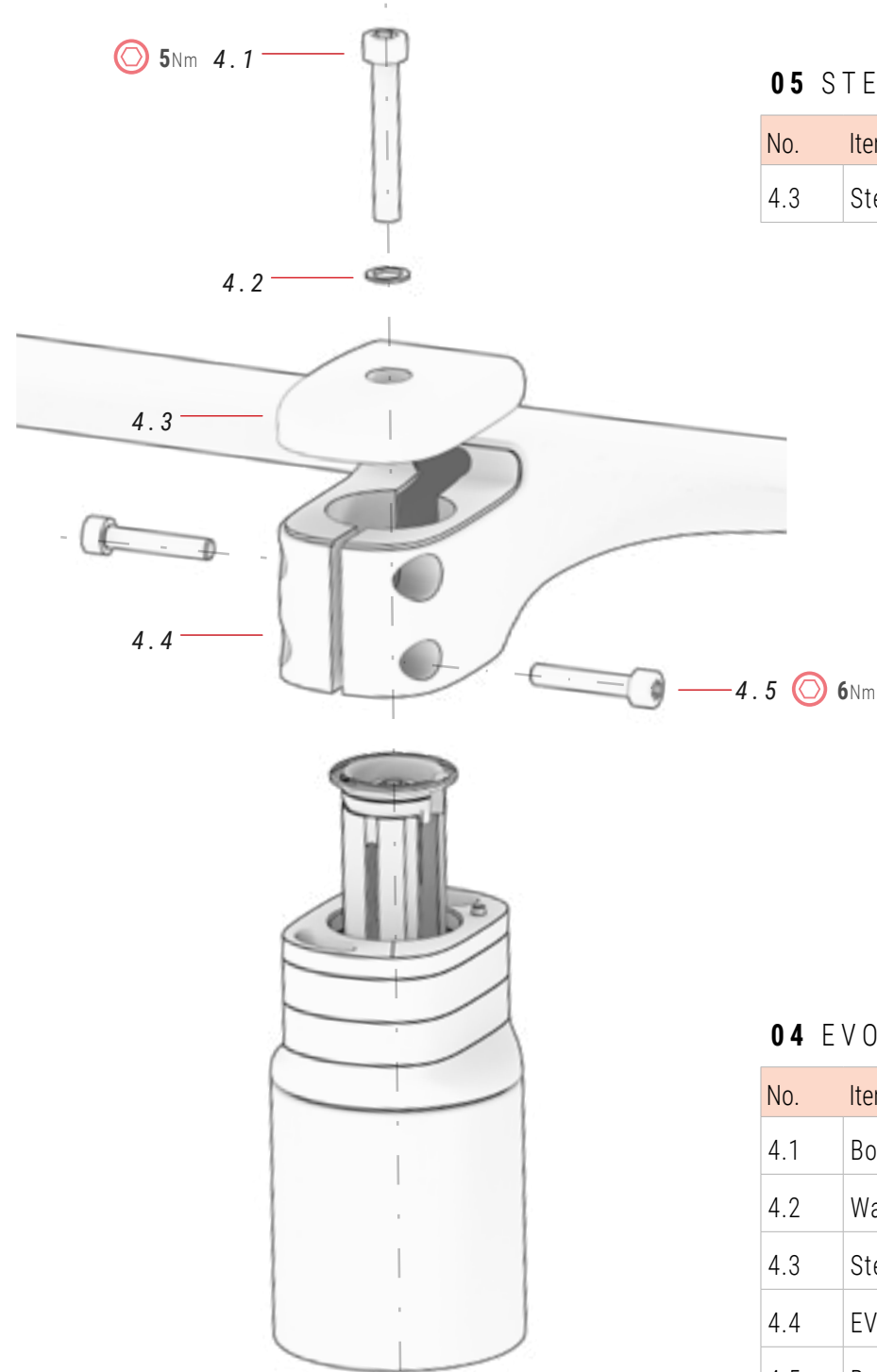

05 STEM COVER

ref. 391855200

No.	Item	Quantity
4.3	Stem cover	1

SIZE	REFERENCE
XS - 380x80	391844800
SM - 400x90	391844900
MD - 420x100	391845000
LA - 420x110	391845100
XL - 440x120	391845200

04 EVO SL HANDLEBAR

ref. BY SIZE

No.	Item	Quantity
4.1	Bolt	1
4.2	Washer	1
4.3	Stem cover	1
4.4	EVO SL handlebar	1
4.5	Bolt	2

HANDLEBAR CABLEROUTING

ALL MODELS

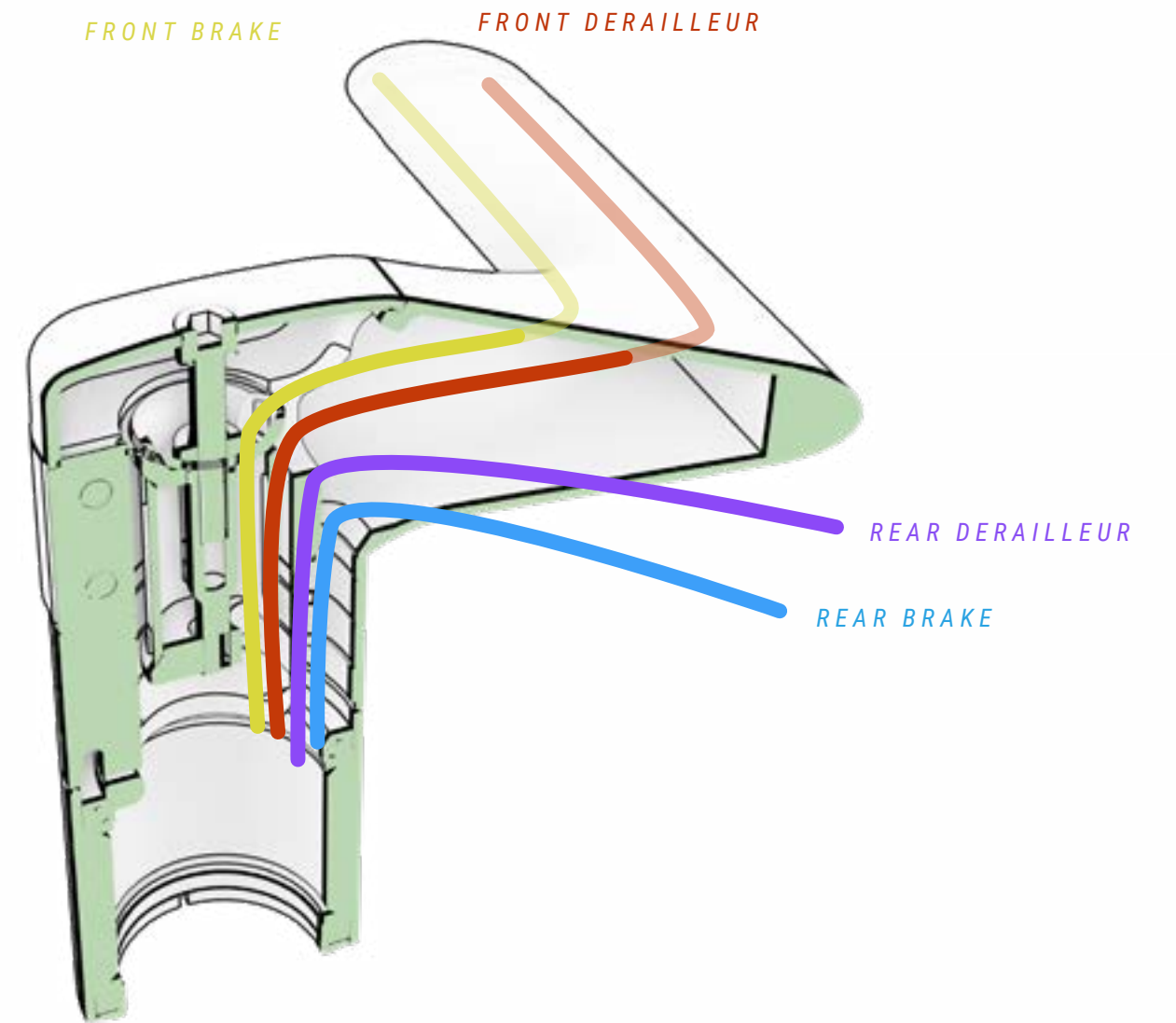

06 HELP AND ADDITIONAL RESOURCES

BH offers different channels to resolve your queries. In addition, you can join our global cyclist community on our social media.

TECHNICAL RESOURCES

You can find all of the resources you need to fine-tune your bicycle on the BH Bikes website. Click on the link below to access the user manuals, apps, warranties, display update files and videos that explain different operations:

<https://www.bhbikes.com/manuals>

You can also check out our step-by-step tutorials to learn how to maintain and fine-tune your bicycle on our specialised Youtube channel:

<https://www.youtube.com/user/ServicioTecnicoBH>

CONTACT US

Our authorised dealers have the necessary knowledge and resources to help you with anything you need in relation to your bicycle. Don't hesitate to contact your nearest store. You can find it by clicking on the link below:

https://www.bhbikes.com/es_INT/tiendas/buscador-de-tiendas

To contact us directly:

Tel.: + 34 945 13 52 02

info@bhbikes.com

P.I. Jundiz- Perretagana 10, 01015 Vitoria, Alava (Spain)

SOCIAL MEDIA

Join our global cyclist community. Discover the BH experiences of other cyclists and share yours.



