



CONTENTS

01 INTRODUCTION	3
SYMBOLS.....	3
02 BH WARRANTY	4
STATUTORY WARRANTY	4
LIFETIME FRAME WARRANTY.....	4
REGISTERING EXTENDED WARRANTIES.....	5
SUBMITTING A WARRANTY CLAIM.....	5
CONDITIONS THAT MAY VOID THE WARRANTY OF ELECTRICAL COMPONENTS.....	5
03 MAINTENANCE	5
INSPECT THE BICYCLE BEFORE USE.....	6
KEEP THE BICYCLE CLEAN.....	6
KEEP THE TRANSMISSION LUBRICATED AT ALL TIMES.....	6
PART MAINTENANCE.....	6
SPARE PARTS.....	8
AFTER A FALL, BLOW OR IMPACT.....	8
04 WARNINGS ON USE	9
MAXIMUM TYRE SIZE.....	9
MINIMUM AND MAXIMUM INSERTION LENGTH OF THE SEAT POST.....	9
MAXIMUM FORK LENGTH (AXLE-TO-CROWN).....	9
MAXIMUM NUMBER OF STEERING SPACERS.....	9
POSITION OF THE SPINDLE INSIDE THE FORK TUBE.....	9
INTENDED USE.....	9
05 WARNINGS ON USE OF THE ELECTRICAL ASSISTANCE SYSTEM	10
CARE AND INSTRUCTIONS FOR USE OF THE ELECTRICAL COMPONENTS AND BATTERIES.....	10
RECOMMENDATIONS TO MAXIMISE THE BATTERY LIFE.....	10
WARNINGS ON THE USE OF BATTERIES.....	10
UNSUITABLE CHARGING AND DISCHARGING ENVIRONMENTS AND SOLUTIONS.....	10
RECYCLING.....	10
06 PEDAL ASSISTANCE SYSTEM OPERATION	11
COMPONENTS OF THE PEDAL ASSISTANCE SYSTEM.....	11
PEDAL ASSISTANCE SYSTEM.....	11
CONTROL UNIT COMPONENTS.....	11
START OF PEDALING.....	12
BATTERY CHARGING.....	12
APP AVINOX RIDE.....	12
OPERATION WITH GARMIN DEVICE.....	13
ELECTRIC SYSTEM UPDATE.....	13
07 SIZES AND MEASUREMENTS	14
08 TECHNICAL SPECIFICATIONS	14

09 ASSEMBLY AND SPARE PARTS	17
DIMENSIONS OF THE STEERING PIPE.....	17
HEADSET ASSEMBLY.....	17
SADDLE SEATPOST INTEGRATED CLAMP ASSEMBLY.....	18
SPLIT PIVOT REAR AXLE AND DERAILLEUR HANGER.....	18
DISASSEMBLY OF THE LINKAGE.....	19
MAIN PIVOT POINT OF THE SWINGARM.....	20
SHOCK ABSORBER ASSEMBLY.....	21
CHAINGUIDE.....	21
MOTOR COVER.....	22
CABLE GUIDE CAPS.....	23
SPEED SENSOR, CABLE GUIDE, AND BOLTS FOR BRAKE ASSEMBLY.....	23
PROTECTORS.....	24
MAIN PIVOT PROTECTOR.....	24
SCHEME OF COMPONENTS OF THE ELECTRICAL SYSTEM.....	25
10 DECLARATION OF CONFORMITY	26
11 HELP AND ADDITIONAL RESOURCES	26

01 INTRODUCTION

This user manual contains important information for proper use and maintenance of the bicycle. In particular, this document contains specific information about iLYNX+ DL ENDURANCE CARBON (ED987 / ED977) iLYNX+ DL ENDURANCE MIX (ED967 / ED957) iLYNX+ DL ENDURANCE ALLOY (ED917 / ED907). Please read the entire manual carefully. The user manuals of all BH models can be consulted on the website at the following address:

<https://www.bhbikes.com/manuals>

Keep in mind that the manuals on the BH BIKES website are updated on a regular basis. Make sure you have downloaded the latest version from the website. You can check the version on the front page.

This document contains additional information to the general user manual, available at:

https://www.bhbikes.com/es_INT/quienes-somos/manuales-descargas

You can check the characteristics, recommendations and warranties of third-party parts on their corresponding official websites.

SYMBOLS

This document contains different icons that refer to use, maintenance and assembly warnings. Carefully read the meaning of each one to prevent improper handling or hazardous situations that may result in serious personal injuries or fatal accidents.

SAFETY

 **DANGER:** refers to a hazardous situation that, if not avoided, will lead to serious injuries or even a fatal accident.

 **WARNING:** refers to a hazardous situation that, if not avoided, could lead to serious injuries or even a fatal accident.

 **ATTENTION:** refers to a hazardous situation that, if not avoided, could cause minor or moderate injuries.

 **RISK OF ELECTRIC SHOCK:** refers to a hazardous situation that, if not avoided, could cause serious injuries due to electric shock or even death.

 **RISK OF SHORT CIRCUIT:** refers to a hazardous situation that, if not avoided, could cause short circuits in the electrical components. Short circuits may cause damage to the electrical components and fire.

TOOLS

 **FLAT WRENCH**

 **ALLEN KEY**

 **TORX KEY**

 **PHILLIPS SCREWDRIVER**

 **10Nm** **TIGHTENING TORQUES:** on one side of each tool symbol, the tightening torque will be indicated in newton metre.

TYPE OF ASSEMBLY COMPOUND

 **OIL:** light lubrication for elements such as chains and cables.

 **GREASE:** assembly grease.

 **CARBON PASTE:** assembly paste used to increase the friction of the carbon elements.

 **ADHESIVE:** use medium strength thread lock.

Adhesive is used to fasten bolts and make sure that they do not come loose due to vibrations when using the bicycle. Add a drop of thread lock to the tip of the screw thread in all cases. Never apply more than one drop around the thread, since this will make it very hard to remove the bolt.



02 BH WARRANTY

BH BIKES undertakes to offer long-lasting bicycles, in compliance with the highest standards of quality. Therefore, in addition to the statutory warranty, BH BIKES offers an additional coverage and warranty. This section defines the different types of warranty and the process that must be followed to register for the additional "LifeTime Frame" warranty.

STATUTORY WARRANTY

The statutory warranty covers the original purchaser in the event of manufacturing defects and/or non-conformities. This warranty applies to frames and components manufactured by BH BIKES. The warranty period will be established according to the current laws of the country where the bicycle was purchased, and will start on the date of purchase. During this period, the holder of the warranty will be entitled to have all manufacturing defects repaired or replaced free of charge, including the reimbursement of transport expenses and any losses caused as a result of this. Different conditions must be met in order to be covered by the warranty:

- This warranty does not affect the consumer's applicable rights, according to the current laws in each country.
- Faulty bicycles or parts will be covered by warranty upon the decision of our Technical Service.
- The warranty does not include the replacement of parts prone to wear and arising from normal use of the bicycle.
- The warranty does not cover defects or broken parts due to improper use of the bicycle, use for competitions, mounting of non-original accessories or improper handling and incorrect maintenance work.
- The warranty does not apply if the inspection before delivery and the corresponding inspection intervals included in this document have not been carried out, observed, documented as required and stamped by an authorised BH dealer.
- Should the repair not be satisfactory and not ensure that the optimum conditions are met according to the intended use, the holder of the warranty will be entitled to request the replacement of the purchased item or faulty part with one of identical characteristics, or to receive a refund of the amount paid for the damaged item or part.
- The warranty period will be interrupted during the repairs or, in the event of replaced items or components, it will be renewed.
- Any claim against this warranty shall expire six months after the end of the warranty validity period.
- All warranty claims must be processed by an authorised dealer.
- Geographical scope: refer to the User Manual or [www. BHbikes.com](http://www.BHbikes.com)

Visit the following link to read the terms and conditions:

https://www.bhbikes.com/es_ES/registro-garantia/registra-tu-bici-garantia-de-por-vida

LIFETIME FRAME WARRANTY

Through its authorised stores, BH Bikes provides the original buyer with a commercial policy to cover any manufacturing defects in frames for a period beyond that specified in the product's statutory warranty, pursuant to the following clauses:

1. **The LIFETIME warranty solely applies to BH frames and bikes that are sold through stores that are authorised by BHBIKES EUROPE S.L.**
 - The buyer must register the LIFETIME warranty online, with the information duly completed, within 30 calendar days of the purchase date, as it appears on the invoice issued by the authorised store.
 - This warranty cannot be transferred to subsequent buyers and it is cancelled when the bicycle is sold to a third party. Original buyer means the individual who registers the warranty at the time of the purchase; the commercial warranty cannot be transferred to third parties who are not the original buyer.
 - It shall be compulsory to have the bicycle serviced in an establishment that is authorised by BHBIKES EUROPE and according to the instructions in the user manual.
2. **The LIFETIME warranty does not cover:**
 - The rear swingarms of the double suspension models, fork, kids' bikes, defects and/or fading of the original paint, or rust caused by natural deterioration.
 - Defects or breakages resulting from an accident or improper and/or negligent use of the bicycle.
 - When components or accessories that are not intended for or are not compatible with the use for which the bicycle was designed have been installed.
 - Defects resulting from improper handling.
 - Scratches, discolouration, or stains caused by the use of abrasive fluids, sharp items, clamps and/or prolonged exposure to sunlight or other weather conditions.
 - Defects caused by the bicycle's normal wear and tear, including those due to material fatigue. Fatigue damage is a sign that the frame has been damaged by normal use, so it is the user's responsibility to regularly inspect the bicycle.
 - Improper use and/or maintenance of the product (carefully read the recommendations for use and cleaning).
 - Frames that have been used in competitions, demos or as rentals.

Read the full terms and conditions at:

https://www.bhbikes.com/es_ES/registro-garantia/registra-tu-bici-garantia-de-por-vida

REGISTERING EXTENDED WARRANTIES

You must register the bicycle within 30 days after purchase to enjoy the BH BIKES additional warranties. The process to activate the extended warranties is described below:

- **LIFETIME FRAME WARRANTY**

You must register the bicycle on the BH BIKES website to enjoy the LIFETIME FRAME extended warranty:

https://www.bhbikes.com/es_ES/registro-garantia/registra-tu-bici-garantia-de-por-vida

Watch this video to find out what you need to do:

<https://youtu.be/47aLVgUI248>

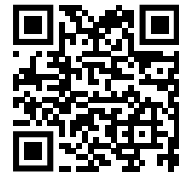

- ⚠ The serial number required to register the bicycle is located on the bottom of the bicycle, on the seat tube, above the bottom bracket:

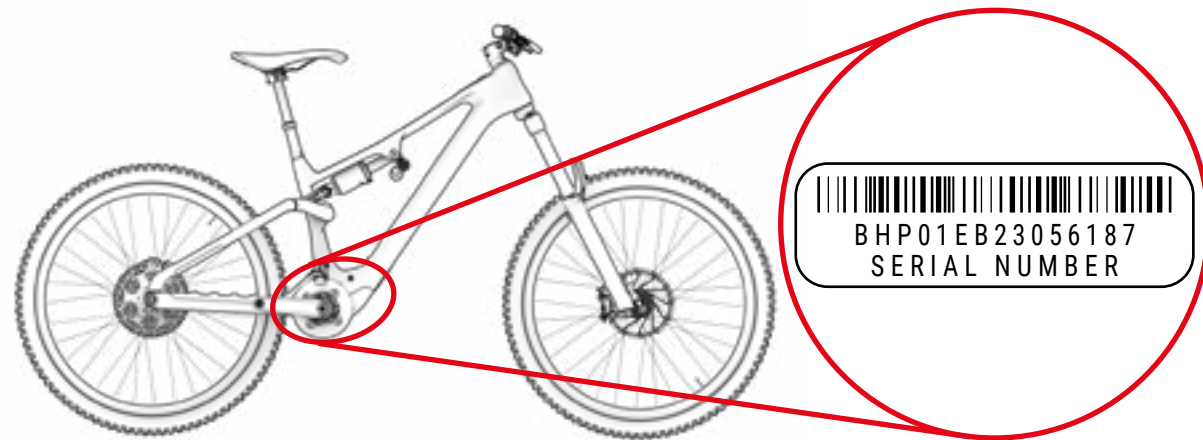

SUBMITTING A WARRANTY CLAIM

All warranty claims must be channelled through an official BH dealer. The dealer will analyse the claim to identify its scope and perform a preliminary assessment of the incident. The dealer will submit and process the claim directly with BH. Once BH has defined the corrective measures required, the dealer will send this information to the customer.

All claims must be processed by the official dealer from which you purchased your bicycle. If this is not possible, please contact us directly. We will help you find an authorised dealer near you:

https://www.bhbikes.com/es_INT/quienes-somos/contacto

CONDITIONS THAT MAY VOID THE WARRANTY OF ELECTRICAL COMPONENTS

The BH battery and electrical components are covered by the statutory warranty, but the following requirements must be met:

- No electrical components must be removed or tampered with.
- The service life will vary according to the use, charging and storage conditions.
- Keep the battery charged at all times. Otherwise, the battery may deteriorate faster than normal.

03 MAINTENANCE

This user manual contains important information for proper use and maintenance of the bicycle. In particular, this document contains specific information about **iLYNX+ DL ENDURANCE CARBON (ED987 / ED977)** **iLYNX+ DL ENDURANCE MIX (ED967 / ED957)** **iLYNX+ DL ENDURANCE ALLOY (ED917 / ED907)**. Please read the entire manual carefully. The user manuals of all BH models can be consulted on the website at the following address:

<https://www.bhbikes.com/manuals>

This document contains additional information to the general user manual, available at:

<https://www.bhbikes.com/manuals>

You can check the characteristics and recommendations of third-party parts on their corresponding official websites.

INSPECT THE BICYCLE BEFORE USE

Bicycles are inspected several times throughout the manufacturing process and then at the BH workshop during the final check. As the bicycle's operation may be affected during transport or third parties may have modified the bicycle before its sale, the following must be checked before each trip:

- **FRAME:** no cracks, damage or strange noises.
- **CHAIN:** it must be lubricated and the transmission system must not make any strange noises.
- **BRAKES:** the brakes must be working properly. When stopped, press the brake lever with enough strength and check that it does not touch the handlebars.
- **TYRES:** the pressure must be correct and there must be no cuts on the tread or on the sides. Also check that the wear level does not exceed the maximum recommended level.
- **WHEELS:** the wheels must rotate freely in order to check how they rotate. Also check the space between the brake lining and the rim, as well as the space between the frame and tyre.
- **STEERING:** the steering must turn smoothly and with no strange noises.
- **SWINGARM ROTATION POINTS:** when weight is exerted on the bicycle, the suspension must work as expected and with no strange noises. If it is not working properly or there is play between the moving parts, this might mean that the tightening torques are incorrect or that the bearings are worn.
- **BEARINGS:** the bearings must work properly and with no strange noises. The bearings are subject to wear and must be replaced to prevent damage to the components on which they are installed.
- **ELECTRICAL SYSTEM:** if the bicycle features an electrical system, check that it is functioning properly by ensuring that the electrical assistance mode is running and that all parts are functioning properly (motor, display, change of assistance mode and speed sensor). If there is no electrical assistance, check that all connections are correct and show no signs of damage.

 Do not ride your bicycle if it does not meet any of these points! A faulty bicycle may cause serious accidents! If you are unsure or have any queries, please contact your nearest BH workshop!

 Check the tightening torques to make sure that they are as described in the recommendations in the user manuals. Failure to observe these recommendations may result in accidents and even death.

 The effect of the ground and the forces exerted on the wheel subject the bicycle to a lot of stress. The different parts will be subject to fatigue and wear because of these dynamic loads. Check the bicycle at regular intervals to look for signs of wear, scratches, bent parts, wear on the finish or the formation of cracks. Parts may fail suddenly after their service life has expired. Take your bicycle to an authorised BH workshop regularly to have these parts replaced if needed.

KEEP THE BICYCLE CLEAN

We recommend you follow these basic prevention measures to make sure that the bicycle is in perfect working order. Failure to observe these recommendations may lead to premature wear or even breakages in specific areas, such as gaskets or moving parts.

- Clean the dust and mud with a damp sponge and a gentle and neutral cleaning product.
- Plastic parts must only be washed with soapy water.
- Tyres can be washed with a sponge or brush and soapy water.
- After cleaning the bicycle, dry it by rubbing it firmly with a smooth cloth.
- After each cleaning, lubricate the transmission elements.

 Dirt may cause damage that can result in accidents or even death.

 Never use pressure washers or steam cleaners.

KEEP THE TRANSMISSION LUBRICATED AT ALL TIMES

After washing the bicycle, the chain transmission's lubrication may have also been washed off. Inspect and lubricate the chain's links, if needed. Excess lubrication may attract more dirt, causing premature wear and incorrect functioning of the system.

 Never use pressure washers or steam cleaners.

PART MAINTENANCE

The bicycle requires regular maintenance and a minimum number of regular inspections. The frequency of the maintenance operations depends on the type of vehicle (leisure, road or mountain bike), as well as the frequency and conditions of use.

PART MAINTENANCE CALENDAR

Part	Action required	Before each outing	Monthly	Annually
Lighting	Functional check.			
Tyres	Pressure check.			
	Inspect the height of the profile and sides.			
Brakes (on the rim)	Check the lever travel, lining strength and rim position.			
	Brake test when stopped.			
	Clean the brake pads.			
Brake cables	Visual inspection.			
Brakes (disc brakes)	Change the brake fluid (DOT fluid).			
Suspension fork	Check the bolts and the corresponding tightening torque.			
	Change the oil and lubricate the elastomer.			
Saddle seat post with suspension	Maintenance.			
	Play check.			
Rims on rim brakes	Inspection and replacement, if needed, of the wall linings.	At the latest after the second part of the brake lining.		
Bottom bracket axle	Check the play.			
	Re-lubrication.			
Chain	Check and lubrication.			
	Check and replacement.	After 800 km.		
Chainsets	Check and tightening.			
Wheels / Spokes	Check wheel spin and spoke tension.			
Headset	Inspection of the headset.			
	Re-lubrication.			
Metal surfaces	Maintenance.	At least once every six months.		
Hubs	Bearing inspection.			
	Re-lubrication.			

Part	Action required	Before each outing	Monthly	Annually
Pedals	Bearing inspection.			
	Lubrication, cleaning the anchoring mechanism.			
Saddle seat post / Stem	Inspection of the fastening screws.			
Rear derailleur / Derailleur	Cleaning, lubrication.			
Quick-release mechanism / Thru-axle	Efficacy check.			
Nuts and bolts	Check and tightening.			
Spokes	Tension check.			
Stem / Saddle seat post	Removing and applying new assembly paste.			
Circuit / Brakes	Disassembly and greasing.			
Components of the electrical assistance system	Check the connections.			
	Check there is no dirt.			

 You do not need to take the bicycle to an expert if you are skilled, experienced and have the appropriate tools. Immediately implement the corrective measures if you detect problems. If you are unsure or have queries, please contact BH.

 The tasks described above must only be carried out by a trusted bike repair expert.

SPARE PARTS

Original parts must be used to ensure the optimum performance of your bicycle and the utmost safety. Failure to use original parts may cause damage that is not covered by the warranty.

The most common spare parts are parts prone to wear. The most common ones are tyres, inner tubes, brake pads, disc brakes and brake pads, as well as rims, when these are part of the brake unit, headlights, position lights, batteries and accumulators.

- **TYRES:** Replace them with an equivalent type of tyre. Check the marking on the outside of the tyre (ETRTO standard). Keep in mind that using a tyre with a larger outer diameter than the recommended one may cause the tip of the foot to touch the front wheel or rear wheel guard when the handlebars turn. The cyclist may lose control of the bicycle and suffer an accident with serious consequences. This can also occur when the pedal chainset is replaced with a longer one.
- **INNER TUBES:** Replace them with a suitable type of inner tube, according to the type of tyre. Refer to the information on the outside of the inner tube (ETRTO standard).
- **DISC BRAKES AND BRAKE PADS:** Follow the instructions supplied by the manufacturer.
- **HEADLIGHTS AND POSITION LIGHTS:** Replace the bulb with one of the same type. Check the indication on the metal area.
- **CHAIN, COG AND CHAIN RINGS:** Follow the instructions supplied by the manufacturer.
- **BATTERIES AND ACCUMULATORS:** Change for the same type. Check the indication on the outer area.

 Remember that the failure to use original parts may cause damage that is not covered by the warranty.

AFTER A FALL, BLOW OR IMPACT

If you suffer a fall, blow or impact, first make sure that you are okay to continue cycling. Do not use the bike if you are injured and ask for medical assistance if needed.

If you are okay to continue cycling, check the bicycle to make sure that it is in perfect working order:

- Check that the wheels are firmly secured and that the rims are in the centre of the frame and fork. Turn the wheels. If they cannot be centred in situ because the gap is too small, separate the brakes from the rim so it can move freely.

 In this case, keep in mind that the braking efficacy will be less.

- Check whether the handlebars or the front of the frame are twisted or broken. Check that the front is firmly seated on the fork, holding the front wheel firmly between your legs and trying to twist the handlebars with respect to the front wheel.
- Check that the chain is fitted correctly. If the bicycle fell onto the transmission side, check that it is working properly. Ask for help to place the bicycle on its saddle and change gears. When the chain fits on the largest cog, check the distance between the gear and the spokes. If the gear or bracket are bent, the first one may become stuck on the spokes - Danger of falling! The gear, rear wheel or frame may be damaged. Check the derailleur. If it has shifted, the chain may come off the gear. The bicycle's transmission will become less effective (also refer to the "Traction" section).
- Check the saddle, upper tube or the bottom bracket box to make sure that there are no defects.
- Lift the bicycle slightly and let it drop onto the ground. If there are any noises, inspect the bicycle for any loose bolts.
- Inspect the entire bicycle again to check for bent areas, worn finish or cracks.
- Ride again carefully if no problems have been detected during the inspection. Do not brake or accelerate suddenly or pedal when going uphill. If you are unsure, wait for a car to pick you up instead of risking an accident. Once home, you should inspect the bicycle carefully again. If you are still unsure or have any queries, please contact your nearest BH workshop!

 Bent aluminium parts must not be straightened, i.e., they must not be repaired. Even afterwards, there is a high risk of breakage, especially in regards to the fork, handlebars, front part, chainsets and pedals. Replace them for greater safety.

04 WARNINGS ON USE

MAXIMUM TYRE SIZE

If you install a tyre of a different size on your bicycle, check and make sure that there are at least 6 mm between the tyre and other parts of the frame and fork.

MINIMUM AND MAXIMUM INSERTION LENGTH OF THE SEAT POST

Failure to observe the maximum and minimum seat post insertion dimensions indicated in this manual may cause a lever effect on the frame. The pressure exerted could damage the frame and cause serious accidents. The warranty does not cover the damage generated by failing to observe these indications.

MAXIMUM FORK LENGTH (AXLE-TO-CROWN)

Observe the maximum length between the fork axle and the lower part of the steering tube (axle-to-crown). If this maximum length is not observed, the frame could be damaged due to withstanding a greater load than that for which it was designed and may cause serious accidents.

MAXIMUM NUMBER OF STEERING SPACERS

This manual specifies the maximum number of steering spacers that can be fitted under the stem. If this maximum quantity is not observed, the materials could be damaged due to withstanding a greater load than that for which they were designed and may cause serious accidents.

POSITION OF THE SPINDLE INSIDE THE FORK TUBE

No steering spacers must be fitted above the stem. Otherwise, the materials could be damaged due to withstanding a greater load than that for which they were designed and may cause serious accidents.

INTENDED USE

Each bicycle has been designed according to a specific intended use. The models described in this manual meet the requirements associated with their intended use:

This category is suitable for restricted downhill use. Downhill riding is permitted up to a speed of 40 km/h, provided jumps do not exceed a height of 120 cm. Use of a bicycle under these conditions is strongly dependent on the experience and skills of the rider.

05 WARNINGS ON USE OF THE ELECTRICAL ASSISTANCE SYSTEM

CARE AND INSTRUCTIONS FOR USE OF THE ELECTRICAL COMPONENTS AND BATTERIES

All BH products and parts have been designed to withstand splashed liquids and rain. However, some practices may cause damage to the parts and short circuits. Do not do the following:

- Wash the bicycle with pressure devices.
- Use the bicycle under adverse weather conditions.
- Transport the bicycle on the outside of a vehicle when it is raining.
- Expose the batteries to very high temperatures. If the temperature exceeds 70°C, this could cause leaks and there could be a risk of fire.
- Fail to observe the working temperature, storage and charging range of the bicycle.

RECOMMENDATIONS TO MAXIMISE THE BATTERY LIFE

We recommend the following to maximise the battery life:

- Charge it on a flat and stable surface.
- Make sure that it is not exposed to direct sunlight.
- Make sure that there are no children or pets near.
- Make sure that there is no rain or dampness.
- The place must be well ventilated and dry.
- The temperature must be between 15-25°C.
- Do not use the battery with a charge of less than 10%. The useful life of the cells may be affected below this charge level.

 Any unauthorised handling of the electrical system's components may cause serious accidents and will void the warranty.

WARNINGS ON THE USE OF BATTERIES

Improper use of the batteries may cause damage and serious accidents. Follow these recommendations to prevent this:

- Always use the original battery charger.
- Never leave the battery near sources of heat.
- Do not heat the battery or throw it into a fire.
- Prevent the battery connections from coming into contact with metal objects.
- Do not submerge the battery in water and prevent splashes and dampness.
- Do not hit or drill holes into the battery.
- Make sure that the battery liquid does not touch your hands or eyes in the event of a leak.
- Do not use it if there are external signs of damage.
- Only clean the battery with a dry or damp cloth.

UNSUITABLE CHARGING AND DISCHARGING ENVIRONMENTS AND SOLUTIONS

The hot and cold environments described below may lead to charging entering standby or sleep mode without fully charging the battery.

- **Winter discharging sleep mode or DUT (Discharge Under Temperature):** Battery discharging will enter the deep sleep mode if the temperature is below -20°C, stopping the pedal assistance system from working and protecting the battery. In such cases, sleep mode will automatically be disabled when the battery exceeds -20°C.
- **Winter charging sleep mode or CUT (Charge Under Temperature):** Battery charging will enter sleep mode if the temperature is below 0°C. If charging starts and the temperature falls below this level due to night cooling or other factors, charging will stop and sleep mode will be activated to protect the battery. In such cases, sleep mode will automatically be disabled when the battery exceeds 0°C.
- **Noise on televisions/radios/computers:** Charging near televisions, radios or similar devices may cause static electricity, flickering images and other interference. If this happens, recharge somewhere that is away from the television or radio (e.g. in another room).

RECYCLING

Ion-lithium batteries can be recycled but they may harm the environment if they are not managed properly after the end of their service life. Follow these steps after the end of their service life:

- Classify and recycle each electrical component in a place prepared for the sustainable recycling of such parts.
- Check and make sure that the applicable regulations of your country are observed with regards to batteries.

06 PEDAL ASSISTANCE SYSTEM OPERATION

COMPONENTS OF THE PEDAL ASSISTANCE SYSTEM

The BH Bikes pedal assistance system is made up of the following components:

- **A. A motor**, which drives the bicycle. (M2S)
- **B. A control unit**, which, among other things, allows you to select the assistance mode. (Left and right wireless controls)
- **C. A battery**, which powers the motor and can be located in different places.
- **D. A torque sensor**, which reads the force applied to the pedal by the user.
- **E. A speed sensor**, which measures the instantaneous speed of travel.

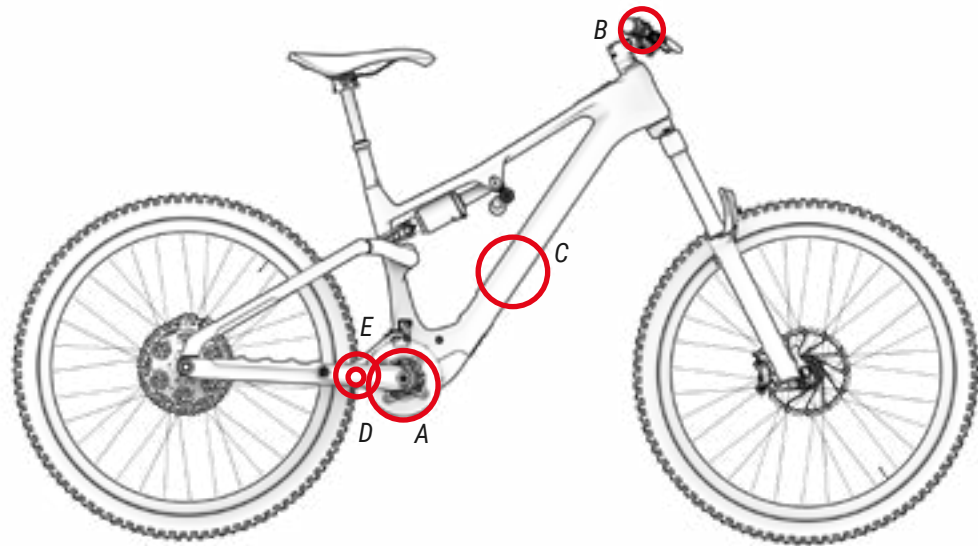

PEDAL ASSISTANCE SYSTEM

The pedal assistance system is designed to provide the optimal amount of assisted power. It provides assistance within a standard range, based on factors such as the pedalling force, the speed of the bicycle and the transmission. The system does not provide assistance in the following situations:

- If the control panel is off.
- When travelling at 25 km/h or faster.
- If you are not pedalling and the throttle function is released at 6 km/h.
- If there is no remaining battery capacity.
- If the assistance mode selected is 0% assistance.

CONTROL UNIT COMPONENTS

The pedal-assist system of BH Bikes consists of the following elements:

This manual only covers the motor and the control units. For full details, please refer to the specific Avinox manual.

<https://avinox.es/>

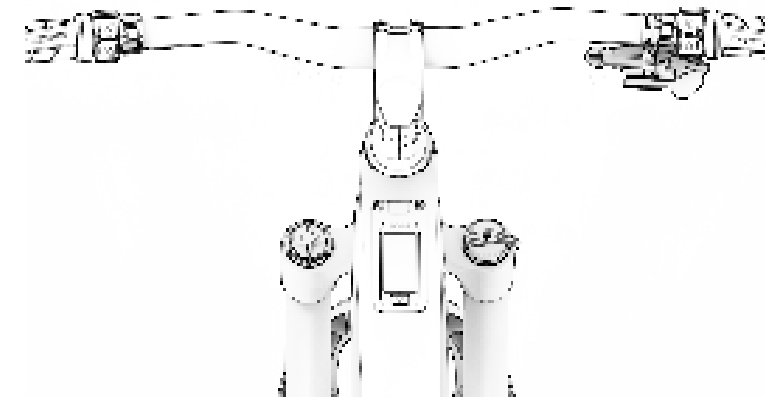

START OF PEDALING

The user should position themselves on the saddle and firmly grip the handlebars before applying pressure to the pedals. Special attention should be paid if starting to pedal in a mode with higher assistance (TRACK and BOOST mode) because the motor will react with maximum thrust, posing a risk of loss of control. To facilitate acceleration, the motor provides an additional initial push as soon as pedaling begins. This makes the effort required to set the bike in motion minimal, helping to integrate into traffic more quickly and safely.

- ⚠️ "Start pedaling with a lower gear (higher gears) and in a lower assistance mode (ECO Mode). In addition to greater control and safety on the bike, this will require less energy consumption and, therefore, provide greater range. It is advised that starting in a higher assistance mode (TRACK and BOOST modes) can pose a safety risk to the user.
- ⚠️ When the user pushes the bicycle while walking alongside it, they should make sure that the system is turned off.

BATTERY CHARGING

Due to its advanced Ion-Lithium technology, it is not necessary to wait for the battery to fully discharge before connecting it to the charger. Likewise, it is not necessary to charge it to 100% before you can use it again. However, please note that, in order to achieve maximum range, it is advisable to proceed with a full charge.

The battery can be charged whether it is inside the bicycle or removed from the frame. Below are the steps to correctly charge the battery in both cases:

- ⚠️ Never charge or use a damaged battery.
- ⚠️ Be cautious and do not touch the charger during the charging process. It can become very hot, especially in high ambient temperatures.
- ⚠️ If a failure occurs during battery charging, unplug the charger power plug from the outlet and wait until the battery cools down.
- ⚠️ Never touch the power plug, charging plug, or contacts with wet hands.
- ⚠️ Ensure there is no foreign matter on the battery contacts before inserting it into the bicycle.
- ⚠️ Do not connect the charger power plug to the battery or bicycle charging port if it is wet or damp. Make sure to connect the power plug only after the battery or bicycle charging port has dried completely.
- ⚠️ Do not apply excessive force on the power plug or pull the cable with the power plug connected to the battery.
- ⚠️ Turn off the pedal-assist system before removing the battery from its location on the bicycle.
- ⚠️ Use both hands to remove the battery from its location, being careful not to drop it. Dropping the battery on your foot can cause injuries and may damage the battery

APP AVINOX RIDE

The specific Avinox Ride app allows, among other things, customizing the level of assistance for each pedal-assist mode. This manual describes the main features and functionalities of this app. For more information, refer to Avinox specific user manual.

This app also serves to update the firmware of the components and to diagnose the problem in case of anomalies.

Also is available for download on both Google Play and the Apple Store. Once downloaded, follow these steps to start using it:

1. **Open the app on your smartphone.**
2. **Register and/or log in.**
3. **Select Connect eBike and select the device you want to connect to. Make sure your bike is stopped and turned on with the battery inserted.**
4. **Connect via Bluetooth to the device and follow the steps in the app to finish setting up your eBike.**
5. **Once connected to your eBike, select the four modes that will appear on your device by default every time you turn on your bike.**



OPERATION WITH GARMIN DEVICE

The ANT+ connection to a Garmin device grants you access to additional assistance display and control functions. The Heart Rate strap connects via the Garmin device. The steps that must be followed to connect iRemote to the Garmin device are described below. The image in the sixth step shows that the Garmin device can be used to check the bicycle's battery status and to select the desired pedal assistance level.

1. PRESS "ADD SENSOR".

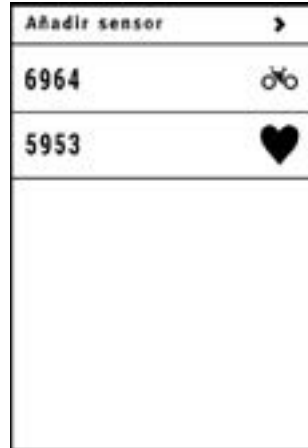

2. CLICK "EBIKE".

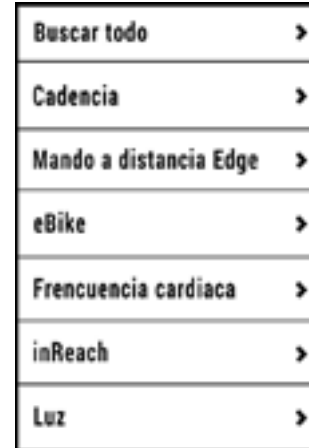

3. PAIRING WITH GARMIN.

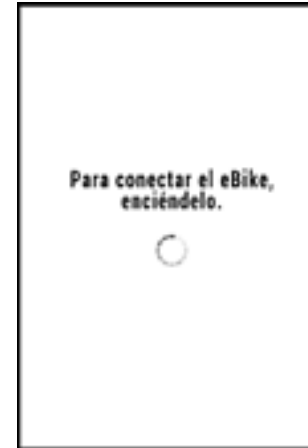

4. SELECT THE EBIKE.

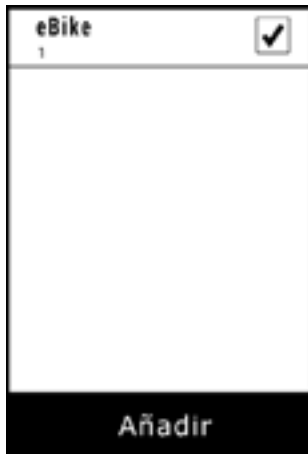

5. SELECT THE CREATED SENSOR.

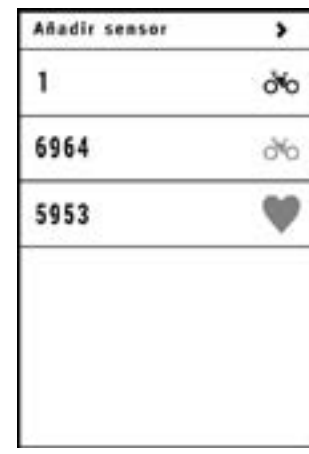

6. GARMINN CONNECTED.



ELECTRIC SYSTEM UPDATE

To update your bike's electrical system, you'll need the Avinox Ride app on your smartphone. Make sure you have the latest version of the app and that your bike is connected to it via Bluetooth. Check for updates in the app's "Settings" section, where you can see if any updates are available and download them. Once downloaded, the update will be transferred to your bike via Bluetooth. Finally, start the installation process from the app, ensuring your bike is connected and near your smartphone.

It is recommended that as part of regular maintenance or repairs with an authorized dealer, the status of updates is checked and necessary actions are carried out.

 Please remember that some actions require advanced knowledge, and incorrect handling can lead to serious accidents. In addition, improper manipulations are not covered by the warranty.

07 SIZES AND MEASUREMENTS

DOBLE SUSPENSION

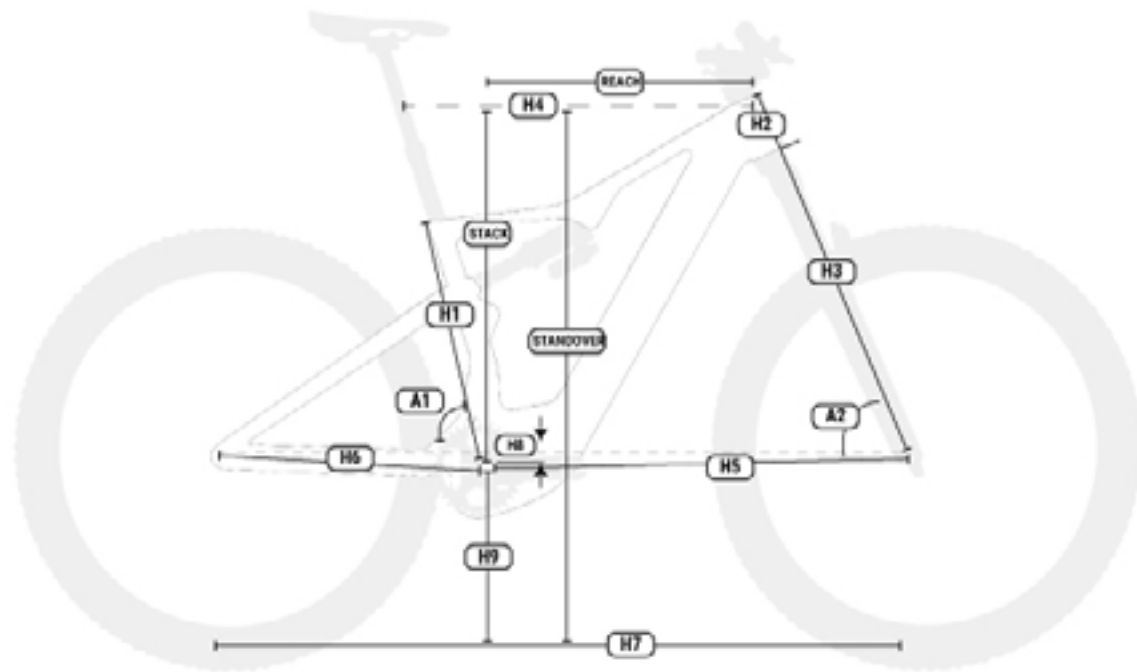

ED987 / ED977 / ED967 / ED957 / ED917 / ED907

ILYNX+ DL ENDURO

	h1	h2	h3	h4	h5	h6	h7	h8	h9	a1	a2	Standover	Reach	Stack
SM	395,5	110	587,7	584,3	796	450	1245,1	23,8		75	63,5	-	445	628,6
MD	415,6	120	587,7	613,2	827,4	450	1276,4	23,8		75	63,5	-	471,9	637,5
LA	435,8	130	587,7	638,3	854,9	450	1304	23,8		75	63,5	-	495	646,5
XL	476	140	587,7	660,3	879,4	450	1328,4	23,8		75	63,5	-	515	655,4

ED817 / ED807 / ED797

ILYNX+ DL TRAIL

	h1	h2	h3	h4	h5	h6	h7	h8	h9	a1	a2	Standover	Reach	Stack
SM	400	110	571,85	590,3	773,6	447	1219	30	-	75	65	-	445	629,4
MD	420	120	571,85	616,3	800,7	447	1246,1	30	-	75	65	-	470	633,9
LA	440	130	571,85	644,5	832	447	1277,5	30	-	75	65	-	495	647,5
XL	480	140	571,85	671,6	861,2	447	1306,7	30	-	75	65	-	520	656,6

08 TECHNICAL SPECIFICATIONS

GENERAL SPECIFICATIONS

Feature	Model	Specification
Frame material		
Front triangle	All	Carbon/Aluminum
Swingarm (chainstays and seatstays)	All	Carbon/Aluminum
Recommended use	All	Trail-Enduro
Sizes	All	S, M, L, XL
Suspension design	All	Double, system Split Pivot
Fork travel	All	160-180
Maximum fork length (axle to crown)	All	580mm
Fork offset	All	Contact the manufacturer
Shock absorber measurements	ED987 / ED977 ED967 / ED957 ED917 / ED907	210x55mm
		210x50mm
Compatibility with coil shock absorbers	All	It depends on the measurements of the shock absorber and spring. Please consult with the manufacturer.
Headset	All	Acros AIX / Acros AZX
Chain line	All	55mm
Tyre size	All	29"
Maximum rear tyre size	All	2.5" (63.5mm)
Maximum front tyre size	All	It depends on the fork
Speed sensor installation	All	6 bolt rotor. In brake disc
Rear axle standard	All	Boost 12x148

GENERAL SPECIFICATIONS

Feature	Model	Specification
Rear axle thread pitch	All	1mm
Rear axle length	All	193mm
Seatpost diameter	All	31.6mm
Seatpost clamp diameter	All	34.9mm
Maximum seatpost insertion		
S	All	200mm
M	All	220mm
L	All	240mm
XL	All	280mm
Compatible with internally routed dropper post	All	Si
Front derailleur	All	No. Only 1X
Maximum chainring size	All	38t
Minimum chainring size	All	34t
Compatible with oval chainring	All	No
Brake type	All	Disc
Rear brake pad standard size	All	Post Mount
Rear brake disc maximum size	All	203mm
Rear brake disc minimum size	All	180mm
Chain guide compatible	All	Yes
ICGS	All	No
Cable routing	All	Internal through DT and CS. Full housing
Compatible with left rear brake cable routing	All	Yes
Bottle cage	Yes	All sizes. Standard bottle cage
Power meter compatibility	Yes	No
Compatible with trailer	Yes	No

Feature	Model	Specification
Rack mounting	All	No
Fender mounting	All	No
Seat for kids mounting	All	No
Recommended maximum weight (rider+gear+luggage)	All	165kg

SPECIFICATIONS OF THE AVINOX MOTOR

Feature	Specification
Nominal power	250W
Voltage	36V
Type	Brushless DC
Assistance	Hasta 25km/h
Maximum torque	130N*m(Normal)- 150N*m(Boost)
Weight	2600g
Pedal assist modes	4 Standard mode (Auto/Eco/Trail/Turbo) Boost mode Walk mode
Walk assist	Yes (hold to activate assist)
Cadence rang	130rpm (150rpm)
Sensors	Cadence / Torque / Speed
System technology	CAN bus and ACC

SPEED SENSOR SPECIFICATIONS

Feature	Specification
Assembly	Integrated into the rear dropout. Internal cable routing
Magnet	On the rear brake disc

SPECIFICATIONS OF THE CONTROLLER

Feature	Specification
Functions	Changing assist mode. Displaying battery charge level. Turning the bike lights on and off. Activating Walk Assist mode.

BATTERY SPECIFICATIONS

Feature	Specification
Voltage	36V
Capacity	800Wh
Weight	3740g
Density	214Wh/kg
Dimensions	560.6 x 710.5 x 49.1 mm

CHARGER SPECIFICATIONS

Feature	Specification
Input	100-240V. 50-60Hz. AC
Output	42V 168W
Charging current	4A
Protection class	IPX3
Charge display	Through LED integrated in charger

09 ASSEMBLY AND SPARE PARTS

DIMENSIONS OF THE STEERING PIPE

ALL MODELS

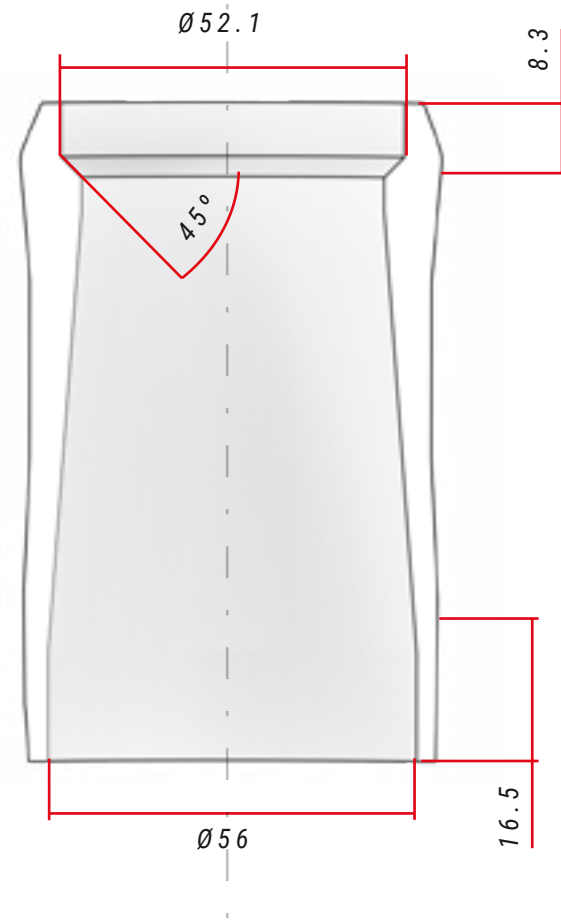

SPECIFICATION OF THE STEERING PIPE

	Type	Contact angle with compression ring/ fork race	Bearing dimensions
Top	1-1/8" Steerer	45°	42x52x7
Bottom	1,5" Steerer	45°	40x52x7, R2

HEADSET ASSEMBLY

ALL MODELS

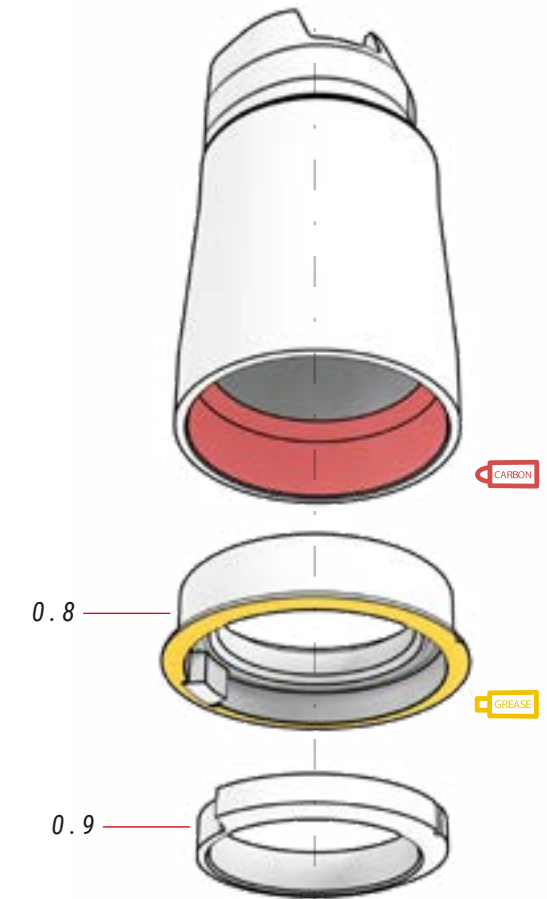
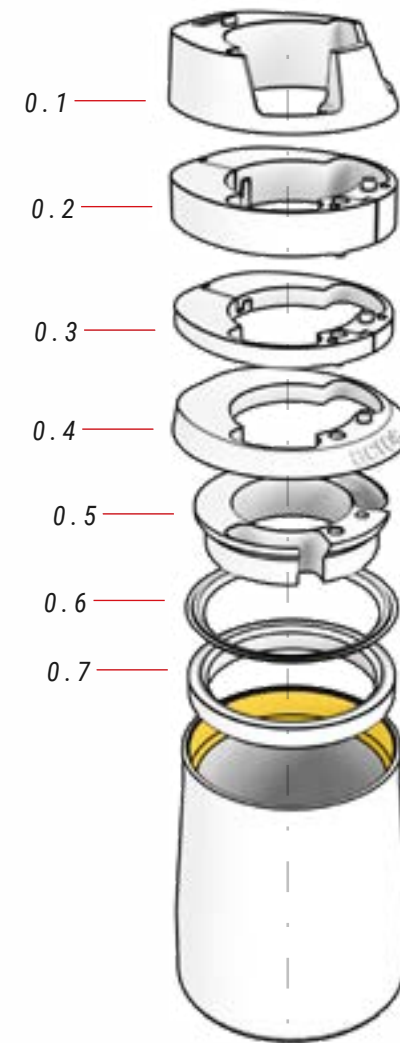

⚠ Piece 0.8 can be installed with the notch facing the frame, but piece 0.9 should always be installed according to the position of the first one, as shown in the images.

00 HEADSET

ref.: 383260100

N°	Item	Qty
0.1	Top cap, cable routing insert	1
0.2	10mm spacer (2 pieces)	1
0.3	5mm spacer (2 pieces)	1
0.4	Headset cap	1
0.5	Cable routing ring	1

N°	Item	Qty
0.6	Seal ring	1
0.7	Angle bearing 42x52x7	1
0.8	Angular contact bearing 40x52x7 / Block-Lock spacer	1
0.9	Base plate 1.5", Block-Lock	1

SADDLE SEATPOST INTEGRATED CLAMP ASSEMBLY

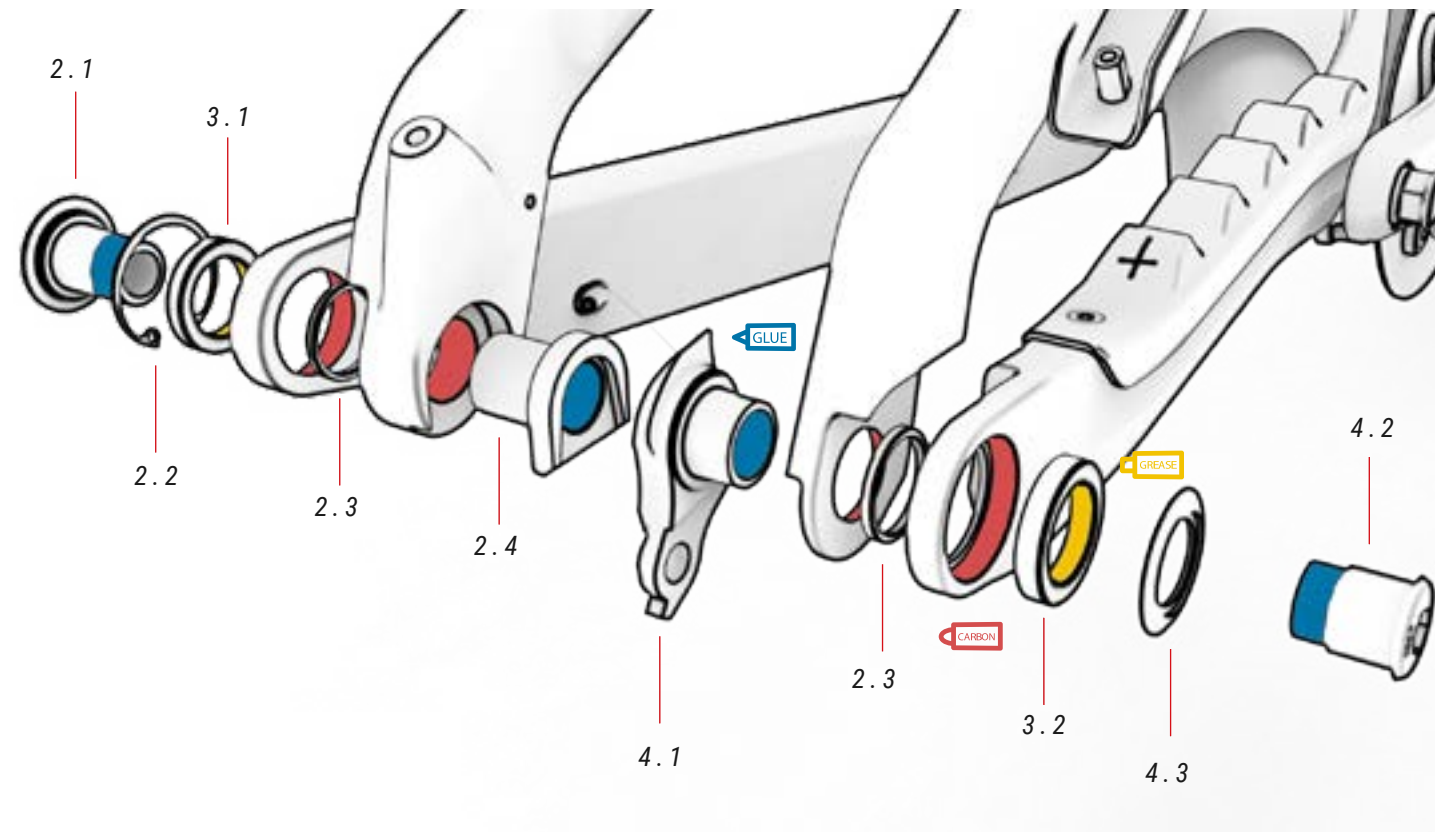

02 SEATPOST CAP

N°	Item	Qty
2.1	Seatpost cap	1

03 SEAT CLAMP

N°	Item	Qty
3.1	Clamp	1
3.2	Screw	1
3.3	Washer	1

SPLIT PIVOT REAR AXLE AND DERAILLEUR HANGER

ALL MODELS

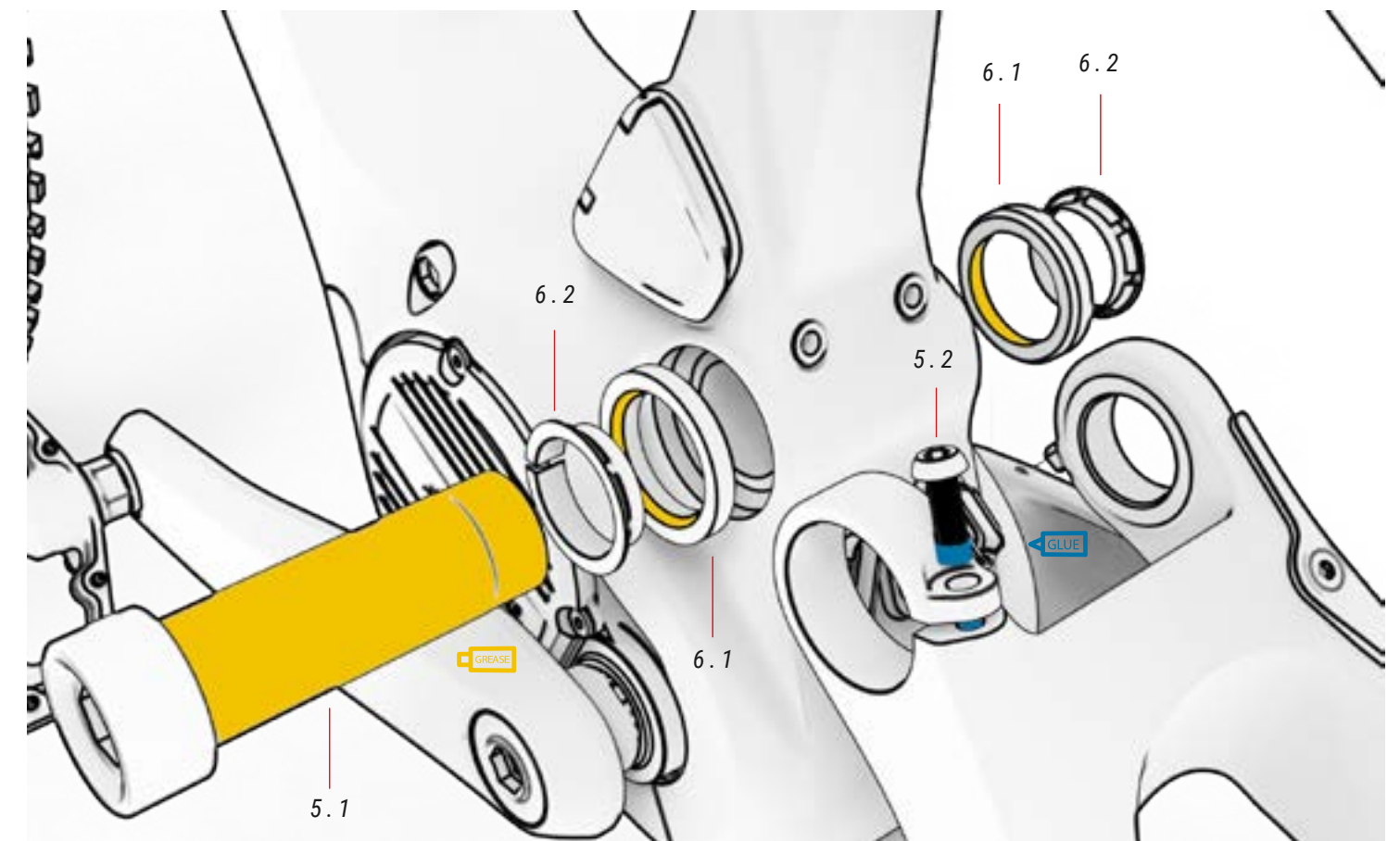

04 SPLIT PIVOT PARTS

N°	Item	Qty
4.1	Screw set	1
4.2	Washer	2
4.3	Screw Dropout	2

05 BEARING DROPOUT

N°	Item	Qty
5.1	Bearing Dropout	2

06 REAR HANGER

N°	Item	Qty
6.1	Rear hanger	1

DISASSEMBLY OF THE LINKAGE

ALL MODELS

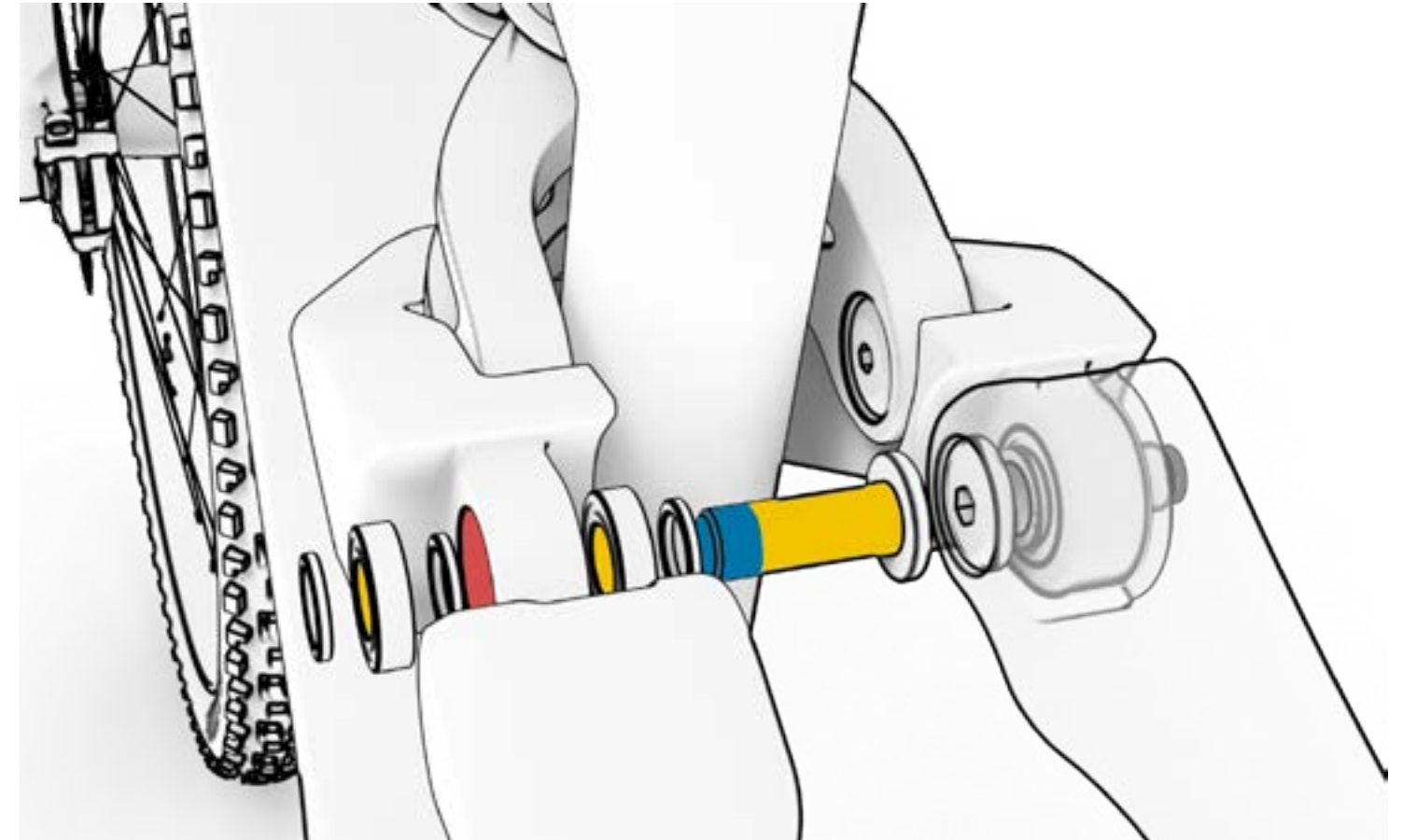
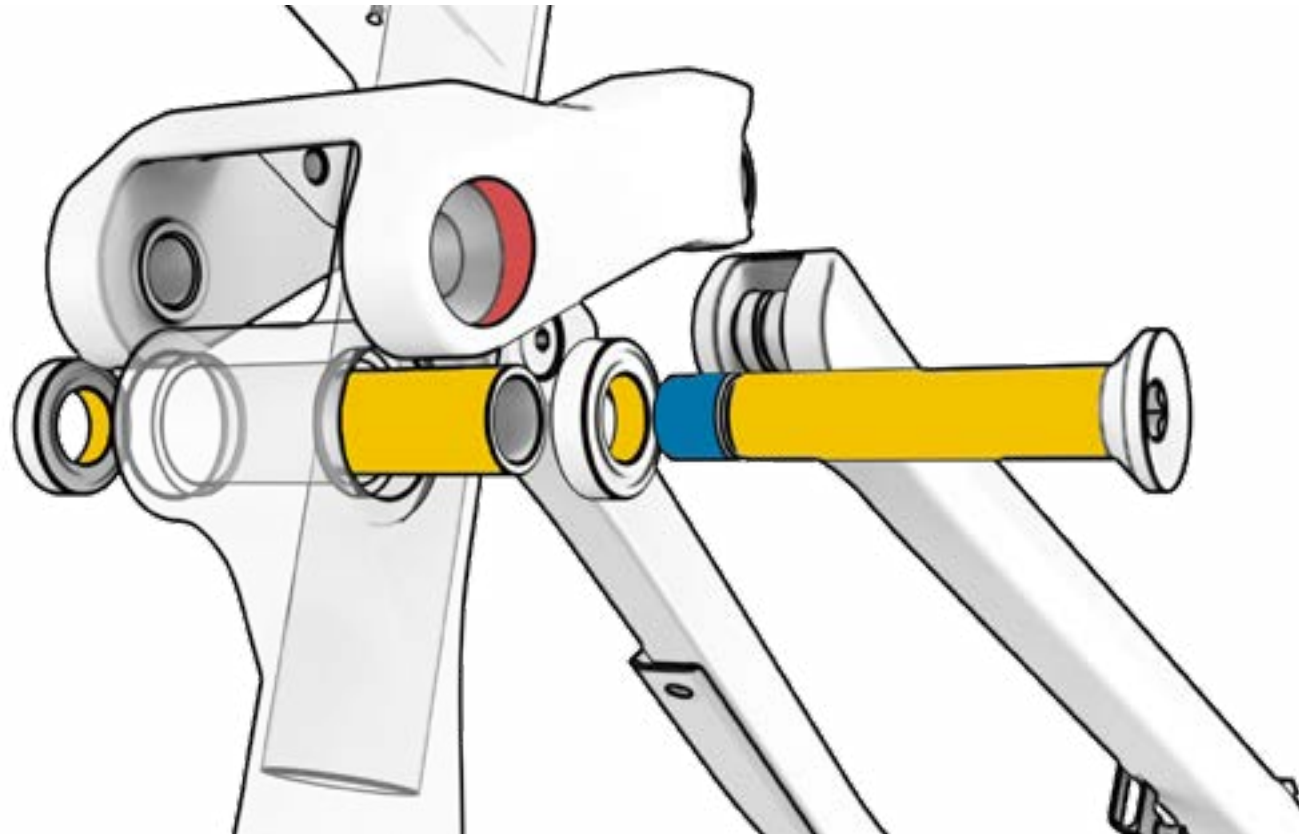

10 CLEVIS ref. 391850000

N°	Item	Qty
10.1	Clevis	1
10.2	Clevis screw	1

11 CLEVIS BEARING ref. 391849900

N°	Item	Qty
11.1	Bearings	2

12 ROCKER BEARING ref. 391849900

N°	Item	Qty
12.1	Bearings	2
12.2	Bearings	2

13 ROCKER AXLE ref. 363301400

N°	Item	Qty
13.1	Thru-axle	1
13.2	Screw	2
13.3	Screw	2
13.4	Screw	1

14 ROCKER ref. 363301400

N°	Item	Qty
14.1	Left rocker	1
14.2	Right rocker	1

MAIN PIVOT POINT OF THE SWINGARM

ALL MODELS

To assemble or disassemble part 7.2, always loosen screw 13.2. Part 7.2 has been designed to be screwed in and out using the 'Pin Spanner' tool or similar. Hole diameter of 2.4mm.

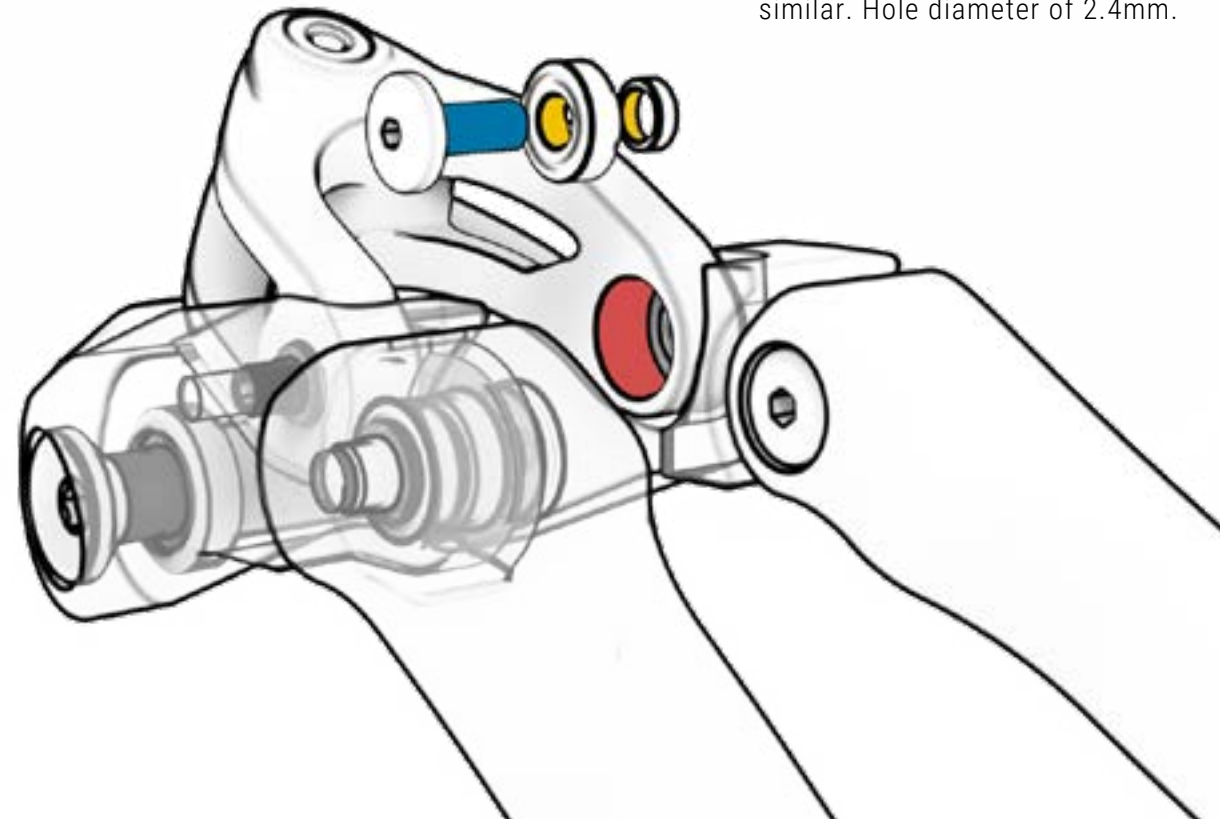

Piece 7.2 should not be tightened to more than 5 Nm as its function is to eliminate play. Piece 13.2 will secure piece 7.2 completely.

07 SWINGARM AXLE

ref. 363301400

N°	Item	Qty
7.1	Thru axle	1
7.2	Bolt	1
7.3	Cap	1
7.4	Screw	1

08 BEARINGS

N°	Item	Qty
8.1	Bearings	2
8.2	Washers	2

SHOCK ABSORBER ASSEMBLY

ALL MODELS

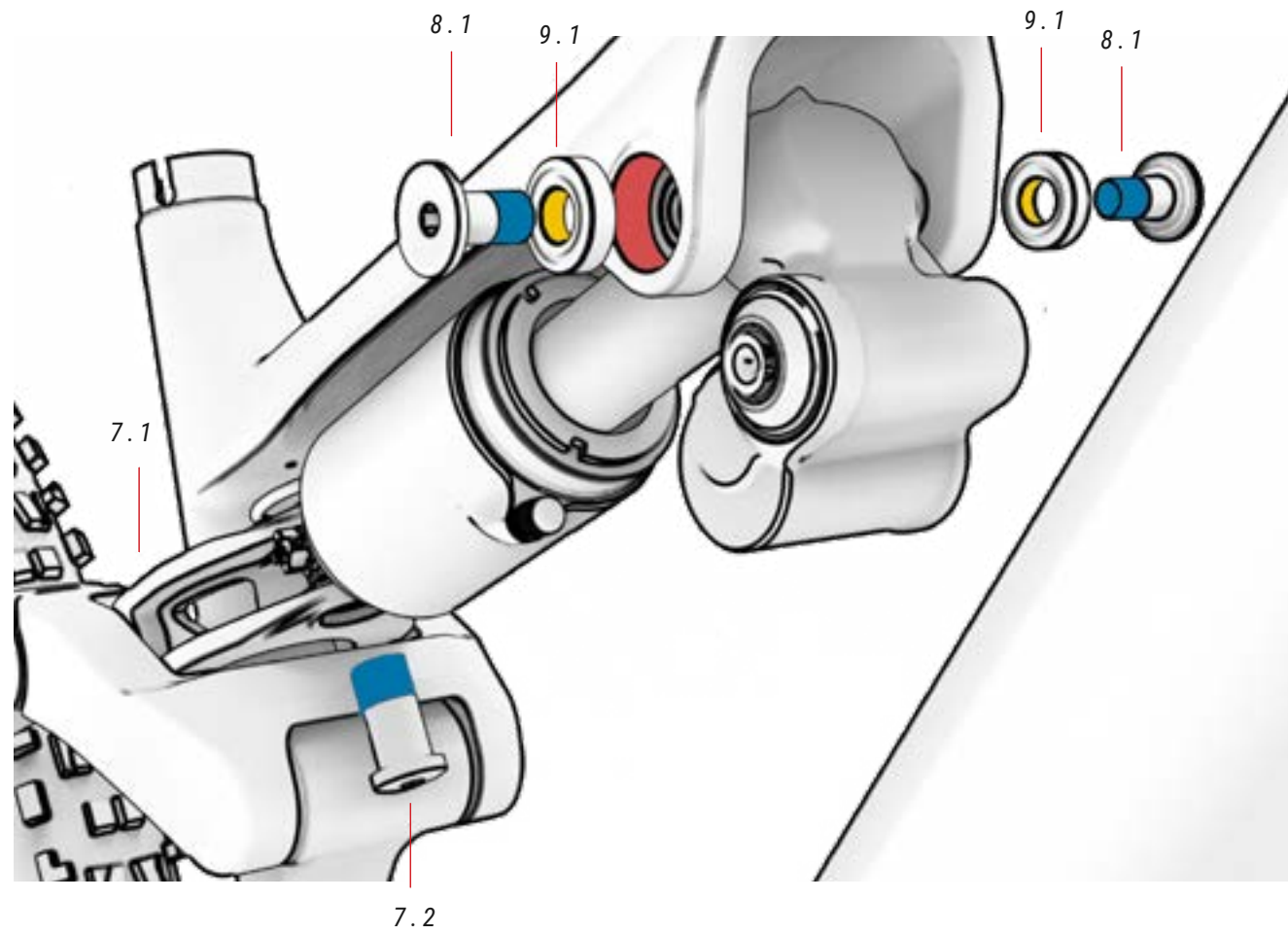

10 CLEVIS

ref. 391817500

N°	Item	Qty
10.1	Clevis	1
10.2	Clevis screw	1

15 SHOCK ABSORBER SCREW

ref. 363302000

N°	Item	Qty
15.1	Shock axle	1
15.2	Shock screw	1

CHAINGUIDE

ALL MODELS

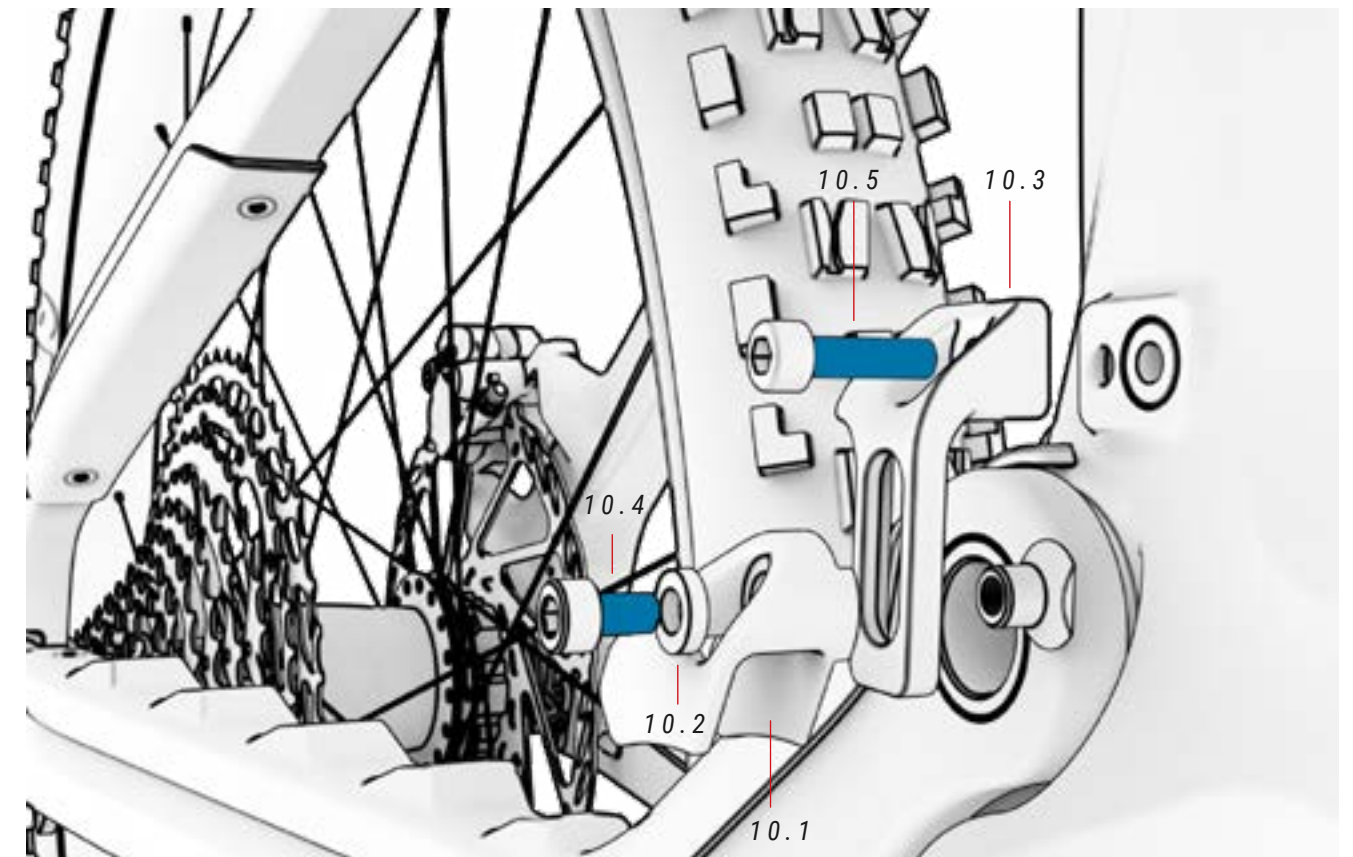

16 CHAINGUIDE

ref. 363300900

N°	Item	Qty
16.1	Guide	1
16.2	Washer	1
16.3	Support	1
16.4	Screw	1
16.5	Screw	1

MOTOR COVER

ALL MODELS

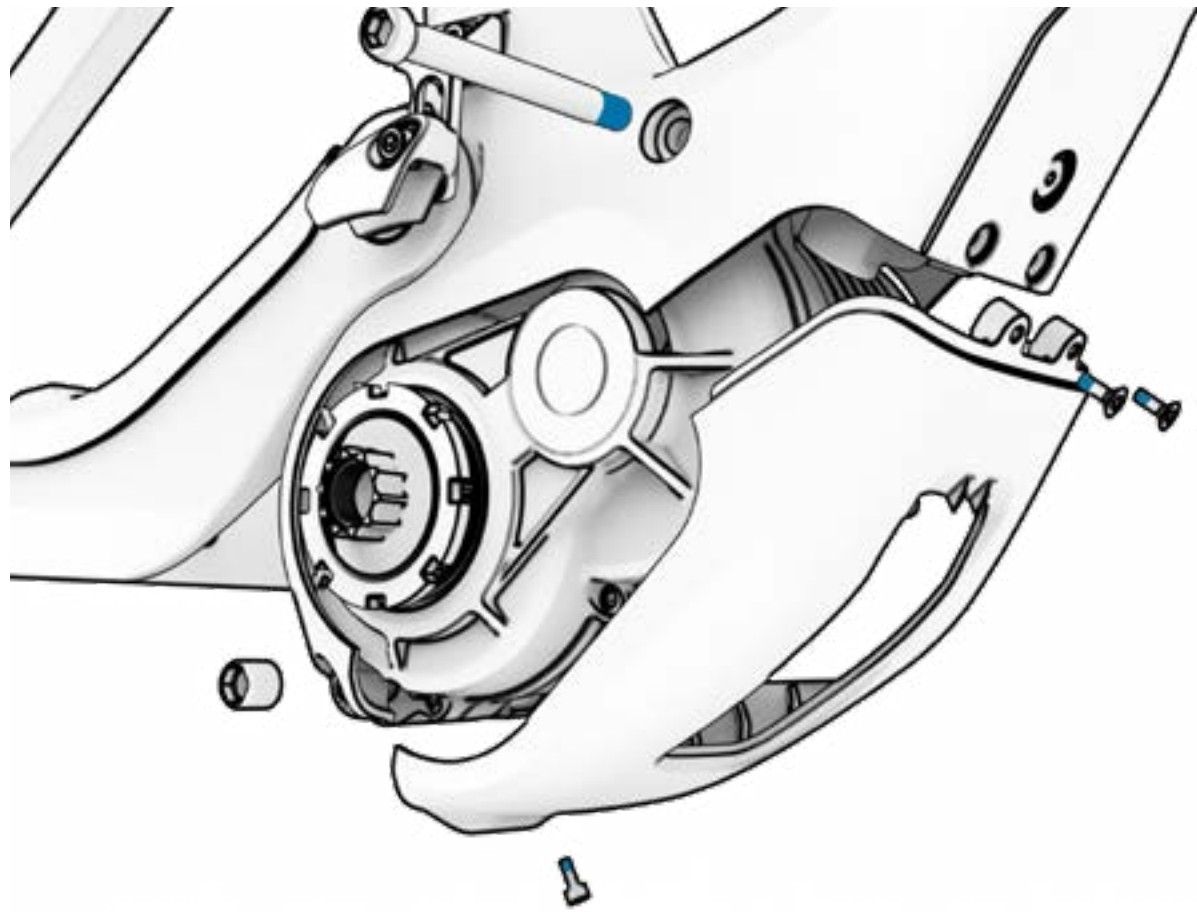

17 CASE AND SCREWS

ref. 363304700

N°	Item	Qty
17.1	Motor casing	1
17.2	Side screw casing	2
17.3	Front screw casing	2

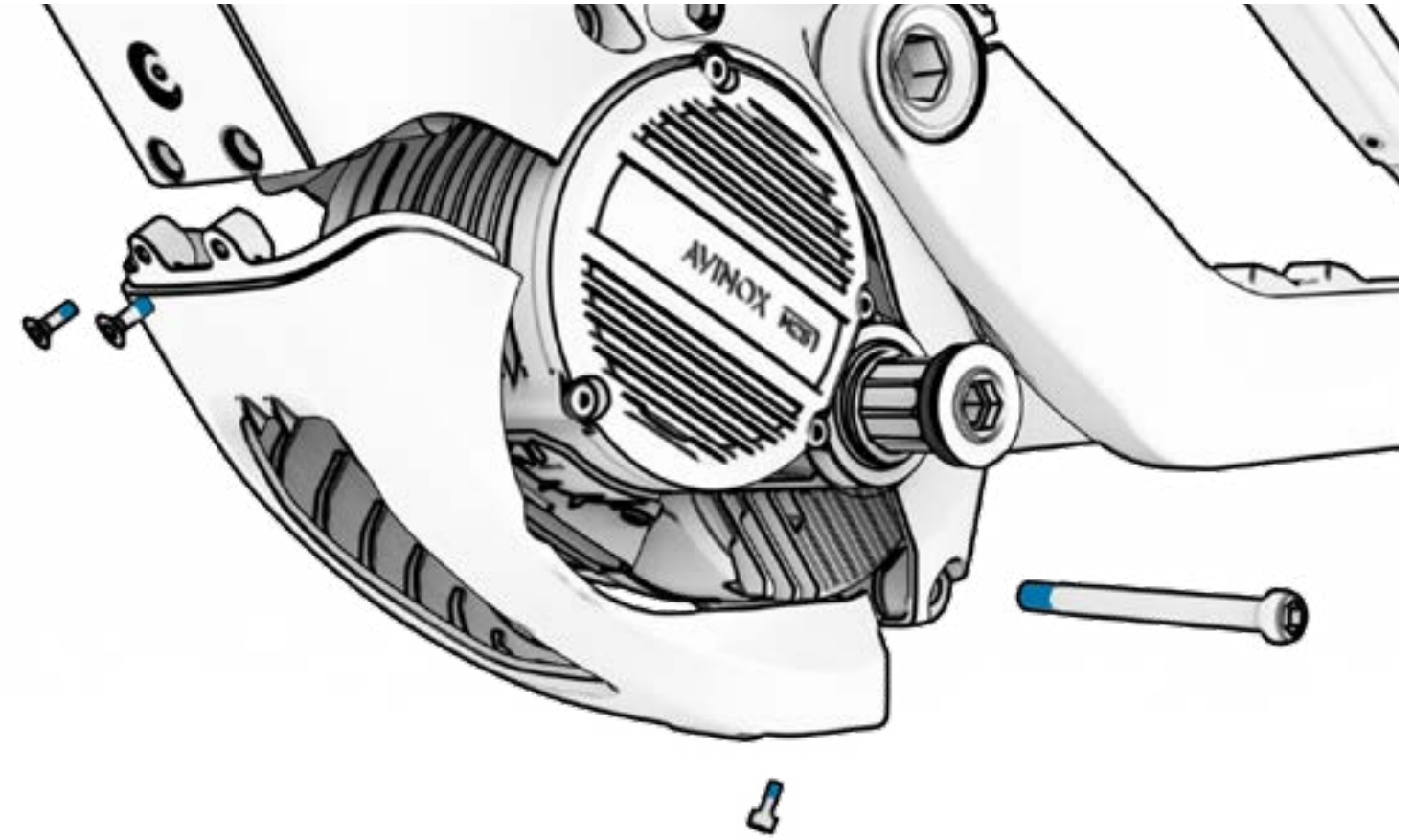

18 BOSCH MOTOR SCREWS

N°	Item	Qty
18.1	Long screw Ref. Bosch: EB11.200.15J	1
18.2	Screw Ref. Bosch: EB11.200.12G	1
18.3	Long casing Ref. Bosch: EB11.200.15H	1
18.4	Short insert Ref. Bosch: EB11.200.12F	1
18.5	Wide adapter Ref. Bosch: EB11.200.0T9	1
18.6	Nut Ref. Bosch: EB11.200.03C	2

CABLE GUIDE CAPS

ALL MODELS

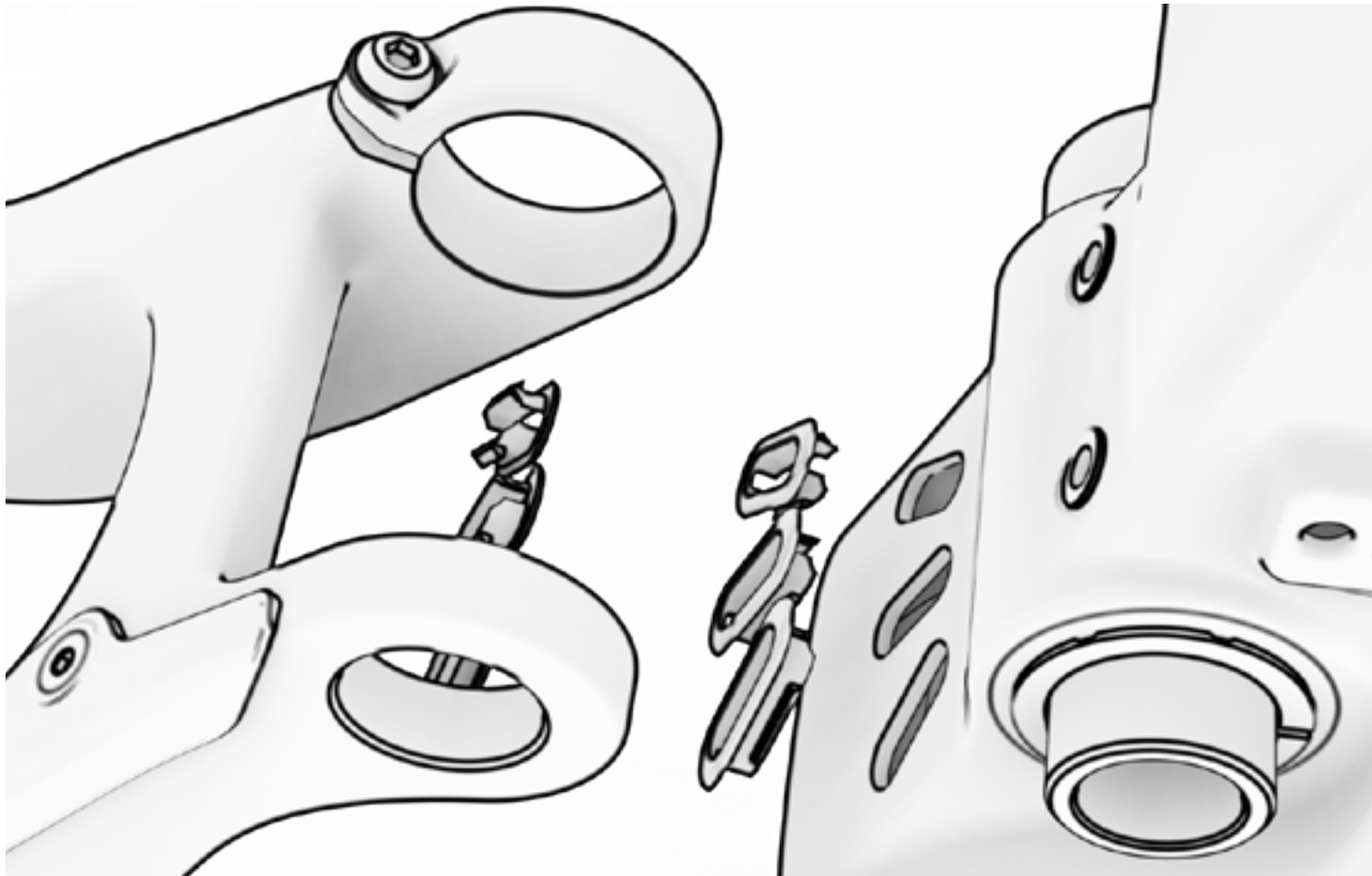

19 PLUGS AND CABLE TIES ref. 363304900

N°	Item	Qty
19.1	Front cable guide	2
19.2	Right rear cable guide	1
19.3	Left rear cable guide	1
19.4	Rear brake guide screws	2
19.5	Rear brake guide	1
19.6	Locking screws	2

SPEED SENSOR, CABLE GUIDE, AND BOLTS FOR BRAKE ASSEMBLY

ALL MODELS

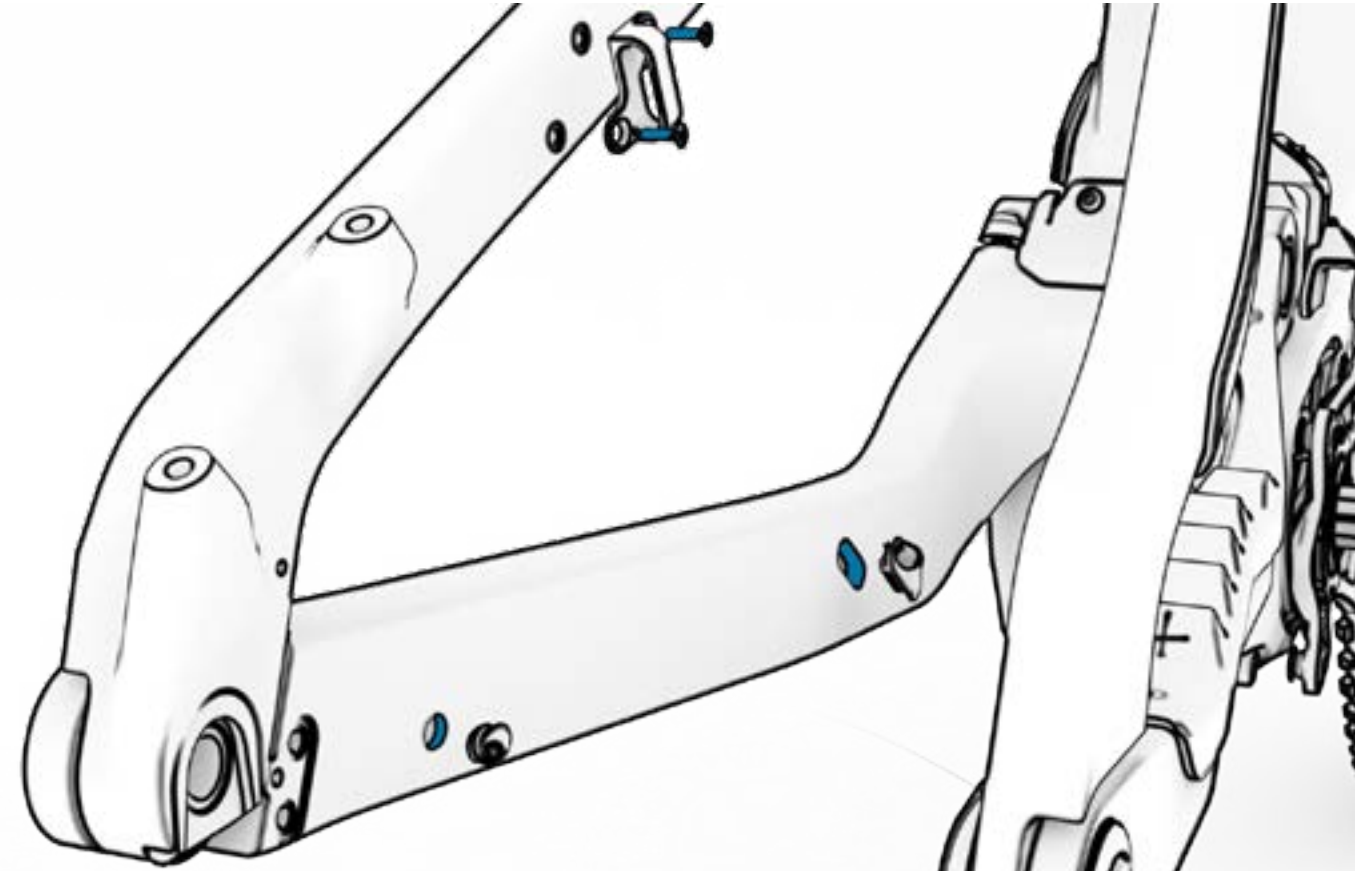

20 SPEED SENSOR

N°	Item	Qty
20.1	Speed sensor Ref. Bosch: EB11.200.02S	1

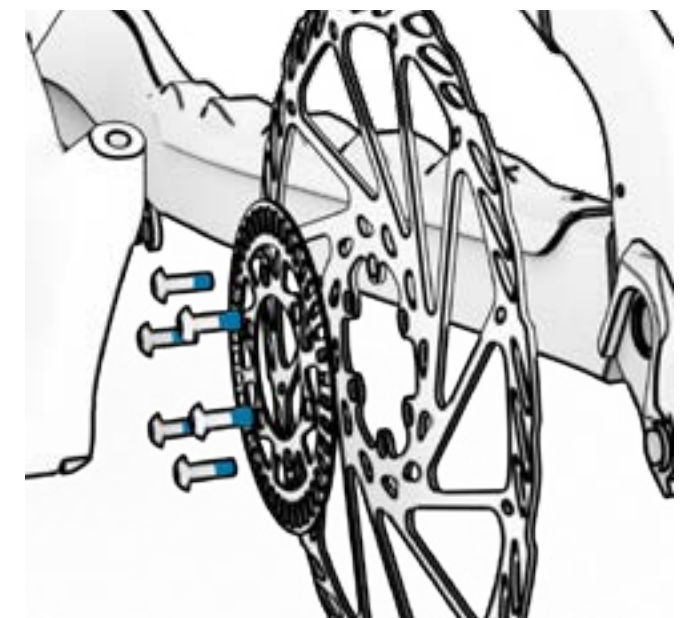

PROTECTORS

ALL MODELS

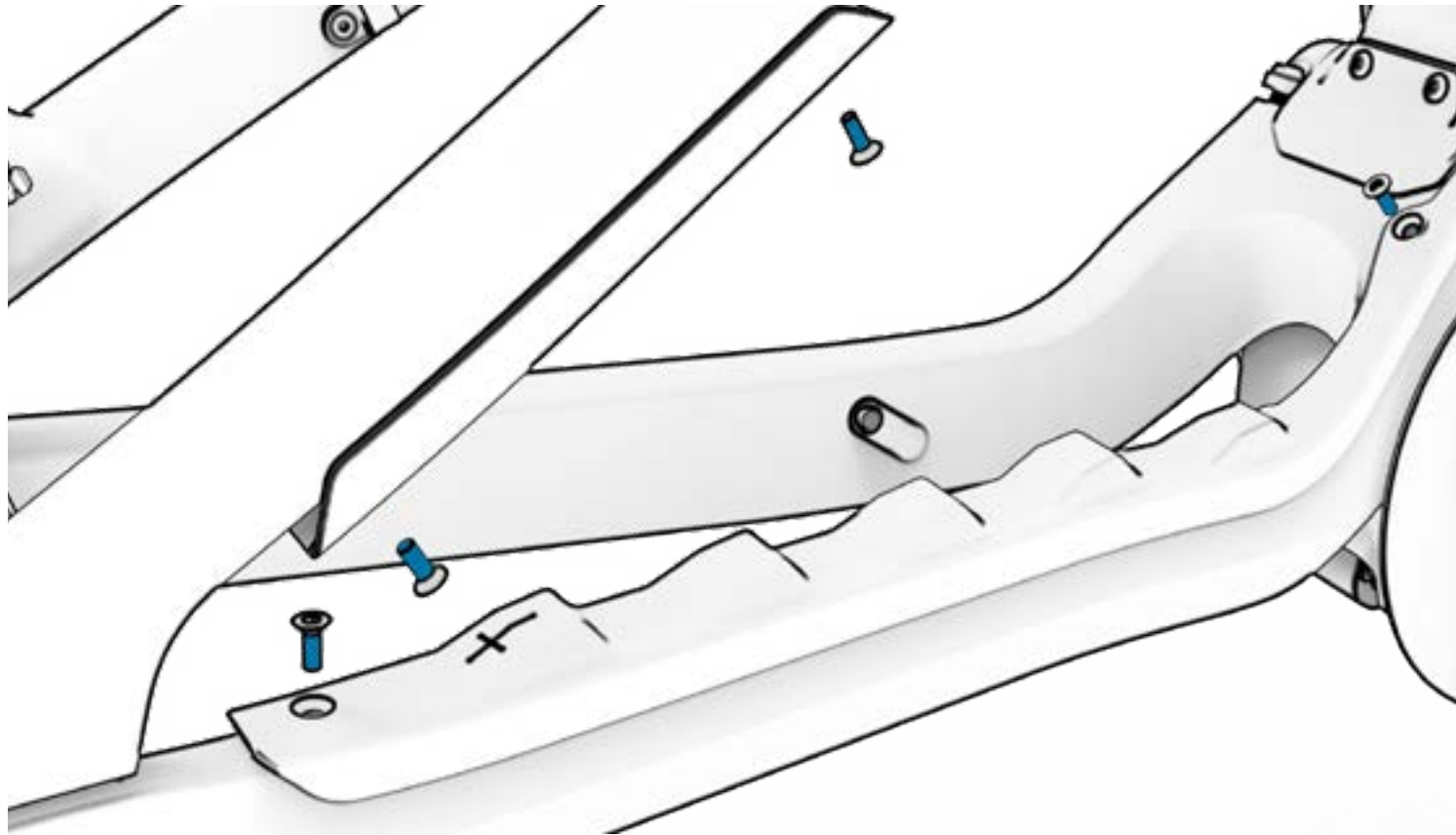

21 PROTECTORS

ref. 363305000

N°	Item	Qty
21.1	Protective strap	1
21.2	Protective sheath	1
21.3	Protective lower diagonal tube	1
21.4	Screws for protective diagonal tube	2
21.5	Mudguard	1
21.6	Mudguard screw	1
21.7	Protective upper diagonal tube	1
21.8	Mudguard screw	2

MAIN PIVOT PROTECTOR

ALL MODELS

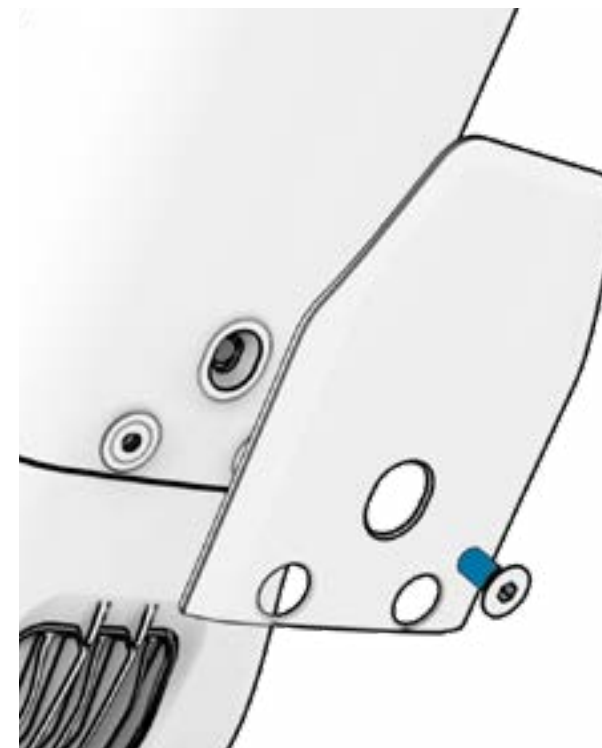
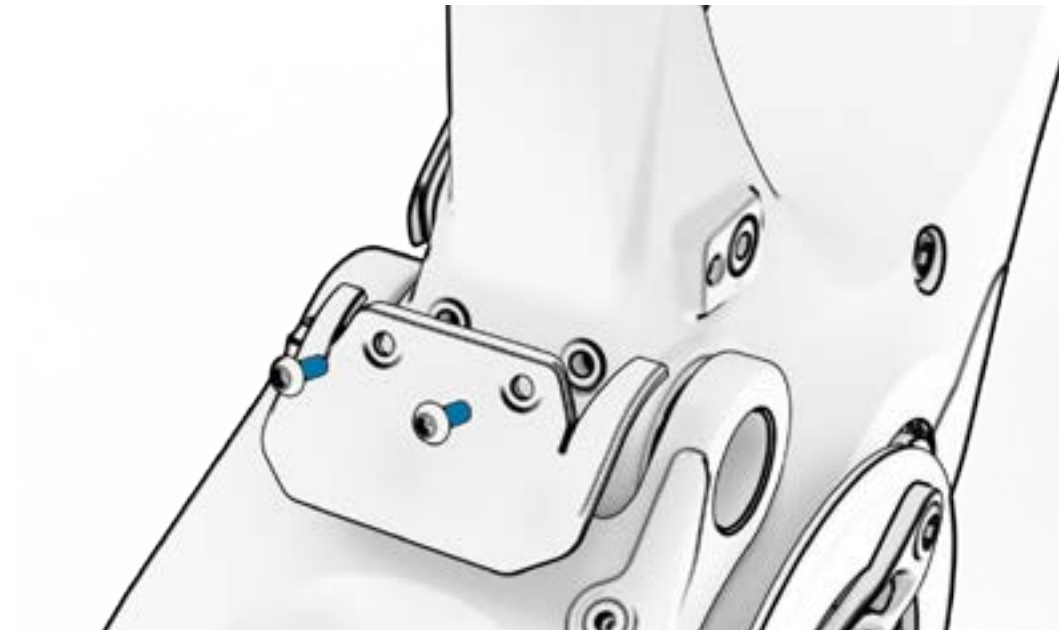

SCHEME OF COMPONENTS OF THE ELECTRICAL SYSTEM

- ⚠ For precise and safe installation of Avinox components, refer to the manufacturer's specific manual.

- ⚠ The incorrect handling of electrical components can lead to damage not covered by the warranty. This damage could also cause serious injury or even death. BH recommends always consulting an official dealer when a diagnosis, repair, or installation of electrical components is required. These actions require advanced technical knowledge.

- ⚠ When an electrical connection comes into contact with moisture or is clogged due to external contamination, a chemical reaction occurs whereby the connections become sulfated. That is, the copper of the contacts oxidizes, causing conductivity failures. The warranty does not cover damage resulting from improper maintenance of the connections. To prevent oxidations, it is sufficient to periodically clean the connections (male and female) with dielectric deoxidizers.

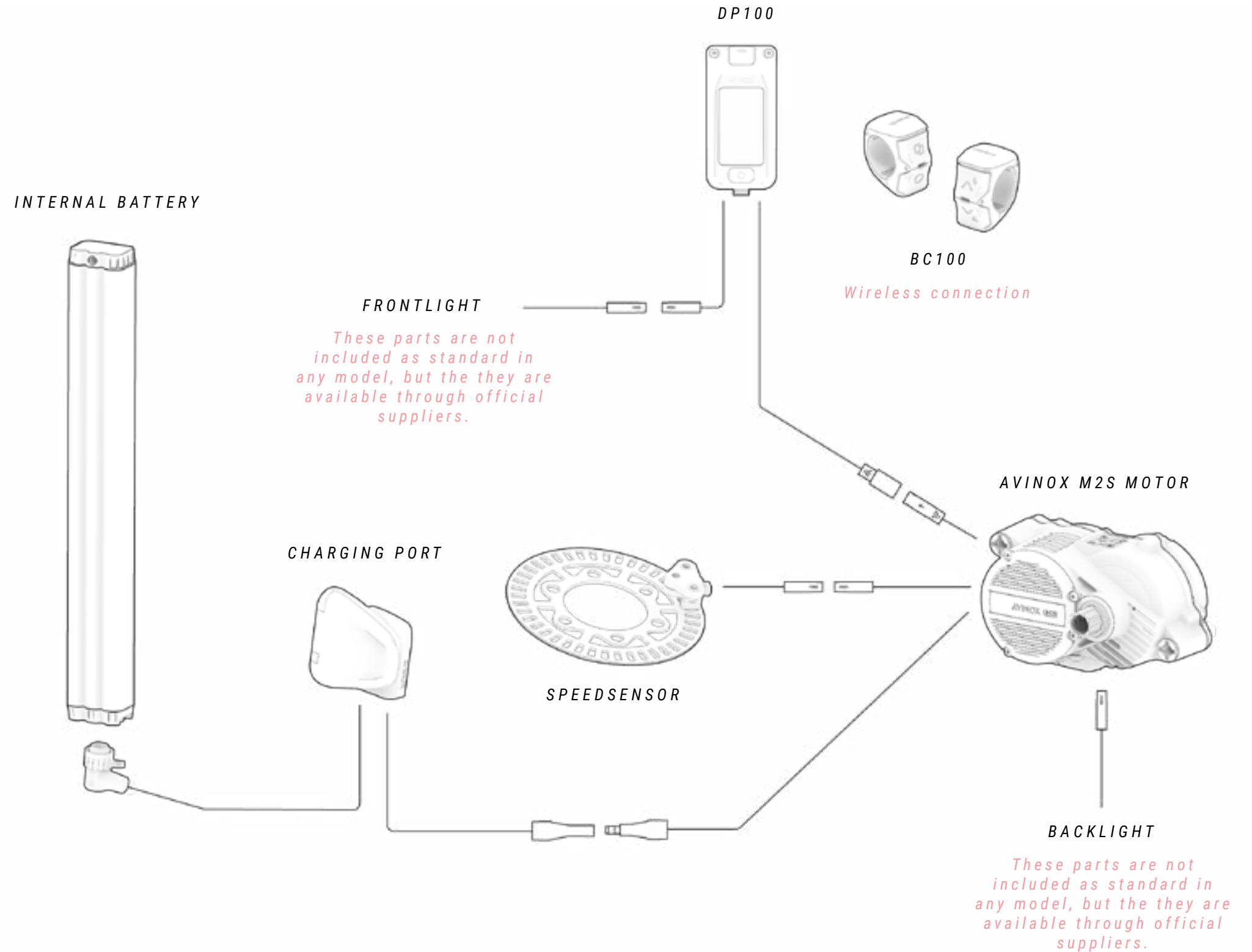

10 DECLARATION OF CONFORMITY

EU Declaration of Conformity 

The manufacturer: BH BIKES EUROPE, SL.
c/ Perretagana 10,
01015 Vitoria, Spain

Hereby declares that the following products:

Product description:  Cycles –Electrically power assisted cycles –EPAC Bicycles

Models designation:

ATOMX LYNX 9.9, ATOMX LYNX 9.8, ATOMX LYNX 9.7, ATOMX LYNX 8.7, ATOMX LYNX 9.2, ATOMX LYNX 9.0,
ATOMX LYNX 8.4, ATOMX LYNX 8.2, ATOMX CROSS,

LYNX+ NX ENDURO CARBON 9.8, LYNX+ NX ENDURO CARBON 9.7, LYNX+ NX ENDURO CARBON 9.6,
LYNX+ NX TRAIL CARBON 8.8, LYNX+ NX TRAIL CARBON 8.7, LYNX+ NX TRAIL CARBON 8.6,
LYNX+ NX ENDURO 9.1, LYNX+ NX ENDURO 9.0, LYNX+ NX TRAIL 8.0, LYNX+ NX TRAIL 7.9,

LYNX+ SL ENDURO CARBON 9.8, LYNX+ SL ENDURO CARBON 9.7, LYNX+ SL ENDURO CARBON 9.6,
LYNX+ SL TRAIL CARBON 8.8, LYNX+ SL TRAIL CARBON 8.7, LYNX+ SL TRAIL CARBON 8.6, LYNX+ SL ENDURO 9.1,
LYNX+ SL ENDURO 9.0, LYNX+ SL TRAIL 8.0, LYNX+ SL TRAIL 7.9,

LYNX TRAIL CARBON 8.9, LYNX TRAIL CARBON 8.7, LYNX TRAIL CARBON 8.5, LYNX TRAIL 8.2, LYNX TRAIL 8.1,
LYNX TRAIL 8.0, LYNX TRAIL 7.9, LYNX RACE CARBON 7.8, LYNX RACE CARBON 7.7,

IAEROLIGHT 1.9, IAEROLIGHT 1.8, IAEROLIGHT 1.7, IRS1 CARBON 1.6, IRS1 CARBON 1.5, IRS1 CARBON 1.4, IRS1 1.2,

IGRAVELX NX CARBON 2.9, IGRAVELX NX CARBON 2.7,

IGRAVELX CARBON 2.9, IGRAVELX CARBON 2.8, IGRAVELX CARBON 2.7, IGRAVELX 2.4, IGRAVELX 2.2,

CORE 29 PRO, CORE 29, CORE JET, CORE CROSS, CORE CITY WAVE, CORE STREET,

ATOM+ NX SUV, ATOM+ NX SUV WAVE, ATOM+ NX DIAMOND, ATOM+ NX DIAMOND WAVE, ATOM+ NX JET,
ATOM+ NX WAVE,

ATOMe LYNX PRO 8.2, ATOMe LYNX 8.0, ATOMe PRO, ATOMe JET PRO, ATOMe CROSS PRO, ATOMe SUV PRO-SE,
ATOMe SUV PRO-S, ATOMe SUV PRO, ATOMe DIAMOND WAVE PRO, ATOMe CITY WAVE PRO,

ATOM LYNX PRO 8.2, ATOM LYNX 8.1, ATOM LYNX 8.0, ATOM 29, ATOM CROSS PRO, ATOM JET, ATOM CROSS,
ATOM SUV PRO, ATOM DIAMOND WAVE PRO, ATOM CITY WAVE PRO, ATOM CITY WAVE, ATOM CITY, ATOM STREET

Year of manufacture: 2025 and 2026

Comply with all of the relevant requirements of the Machinery Directive (2006/42/EC).
Comply with Low Voltage Directive (LVD) 2014/35/EU.
Comply with all of the relevant requirements of RD 139/2014, de 9 de Mayo.

Furthermore, the machine complies with all of the requirements of the Electromagnetic Compatibility Directive 2014/53/EU.

The production control is assured by our Quality Management System, which fulfills the requirements of the standard ISO 9001

The following harmonized standards have been applied:
DIN EN 15194 Cycles – Electrically power assisted cycles – EPAC bicycles;
DIN ISO 4210-1:2014-5-6-7-8-9 Safety requirements for bicycles

Technical documentation filed at:
BH BIKES EUROPE, SL.
c/ Perretagana 10,
01015 Vitoria, Spain

Prepared and reviewed by the BH Quality Department (Headquarters)

Rev.19 01/06/2025 Page 1 of 1

11 HELP AND ADDITIONAL RESOURCES

At BH, we provide you with various means to address all your doubts. Additionally, you can become a part of our global cycling community through our social media channels.

TECHNICAL RESOURCES

On the BH Bikes website, you will find all the necessary resources to tune up your bike. In the following link, you can access user manuals, apps, warranties, files for updating displays, and explanatory videos for various operations:

<https://www.bhbikes.com/manuals>

You can also check out our step-by-step tutorials to learn how to maintain and fine-tune your bicycle on our specialised

Youtube channel::

<https://www.youtube.com/user/ServicioTecnicoBH>

CONTACT US

Our authorised dealers have the necessary knowledge and resources to help you with anything you need in relation to your bicycle. Don't hesitate to contact your nearest store. You can find it by clicking on the link below::

https://www.bhbikes.com/es_ES/busca-tu-tienda-mas-cercana/buscador-de-tiendas

To contact us directly:

Tel: + 34 945 13 52 02

info@bhbikes.com

P.I. Jundiz- Perretagana 10, 01015 Vitoria, Alava (Spain)

SOCIAL MEDIA

Join our global cyclist community. Discover the BH experiences of other cyclists and share yours.





www.bhbikes.com



BH